

# SERVICE MANUAL

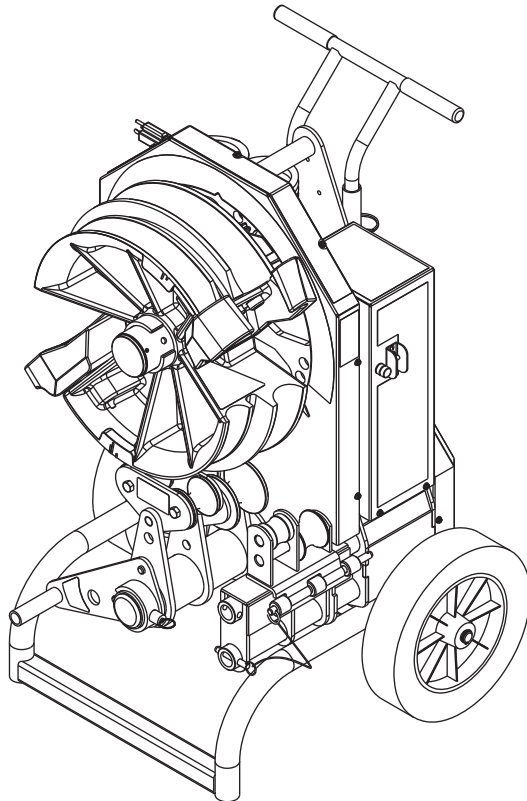

Shown with optional  
1-1/2" to 2" EMT/rigid  
combination shoe group



## **555<sup>®</sup> Series Electric Benders**



**Read and understand** all of the instructions and safety information in this manual before operating or servicing this tool.

Register this product at [www.greenlee.com](http://www.greenlee.com)

## Table of Contents

Safety .....	2
Purpose of this Manual .....	2
Other Publications .....	2
Important Safety Information .....	3–5
Service Instructions .....	6–11
Illustrations and Parts Lists	
Main .....	12–17
Bending Attachments .....	18–19
Wiring Diagrams .....	20

## Safety

Safety is essential in the use and maintenance of Greenlee tools and equipment. This manual and any markings on the tool provide information for avoiding hazards and unsafe practices related to the use of this tool. Observe all of the safety information provided.

## Purpose of this Manual

This manual is intended to familiarize authorized Greenlee service center personnel with the safe operation and maintenance procedures for the Greenlee 555® Series Electric Benders.

Keep this manual available to all personnel.

Replacement manuals are available upon request at no charge at [www.greenlee.com](http://www.greenlee.com).

## Other Publications

Instruction Manuals:

- 555DX and 555CX: Publication 52055799
- 555DX-22: Publication 52060434



**Do not discard this product or throw away!**

For recycling information, go to [www.greenlee.com](http://www.greenlee.com).

All specifications are nominal and may change as design improvements occur. Greenlee Textron Inc. shall not be liable for damages resulting from misapplication or misuse of its products. 555 is a registered trademark of Textron Innovations Inc.

# **KEEP THIS MANUAL**

## IMPORTANT SAFETY INFORMATION



### SAFETY ALERT SYMBOL

This symbol is used to call your attention to hazards or unsafe practices which could result in an injury or property damage. The signal word, defined below, indicates the severity of the hazard. The message after the signal word provides information for preventing or avoiding the hazard.

#### ⚠ DANGER

Immediate hazards which, if not avoided, **WILL** result in severe injury or death.

#### ⚠ WARNING

Hazards which, if not avoided, **COULD** result in severe injury or death.

#### ⚠ CAUTION

Hazards or unsafe practices which, if not avoided, **MAY** result in injury or property damage.



#### ⚠ DANGER

Read and understand all of the instructions and safety information in this manual before operating or servicing this tool. Refer also to the Instruction Manual, which is listed under "Other Publications."

Failure to observe this warning will result in severe injury or death.



#### ⚠ DANGER

Do not use this tool in a hazardous environment. Hazards include flammable liquids, gases, or other materials. Using this tool in a hazardous environment can result in a fire or explosion.

Failure to observe this warning will result in severe injury or death.

#### ⚠ WARNING

Electric shock hazard:

- **For 120 Volt Bender:** Connect the power cord to a 120 volt, 20 amp receptacle on a ground fault protected circuit only. Refer to "Grounding Instructions" in the Instruction Manual, which is listed under "Other Publications."
- **For 220 Volt Bender:** Connect the power cord to a 220 volt, 15 amp receptacle on a ground fault protected circuit only. Refer to "Grounding Instructions" in the Instruction Manual, which is listed under "Other Publications."
- Do not modify the power cord or plug.
- Inspect the power cord before use. Repair or replace the cord if damaged.
- Disconnect the unit from power before servicing.

Failure to observe these warnings could result in severe injury or death.



#### ⚠ WARNING

For continued protection against risk of fire and electric shock, replace **ONLY** with same manufacturer, type, and rating of fuse. Refer to the "Maintenance" section of the Instruction Manual, which is listed under "Other Publications."

Failure to observe this warning could result in severe injury or death.

#### ⚠ WARNING



- Do not use in dangerous environment. Do not use power tools in damp or wet locations, or expose them to rain. Keep work area well lighted.
- Do not immerse the pendant switch in water or any other liquid.

Failure to observe these warnings could result in severe injury or death.

## IMPORTANT SAFETY INFORMATION

	<p><b>⚠ WARNING</b></p>
	<p>Always use safety glasses. Everyday glasses only have impact resistant lenses; they are NOT safety glasses. When using in dusty environment, use face or dust mask.</p> <p>Failure to wear eye protection could result in serious eye injury from flying debris.</p>

<p><b>⚠ WARNING</b></p>
<p>Make sure that the handle is properly installed and secured with the safety spring clips and snap pins before lifting or moving the bender. An improperly installed handle could allow the bender to fall, injuring nearby personnel.</p> <p>Failure to observe this warning could result in severe injury or death.</p>

	<p><b>⚠ WARNING</b></p>
	<ul style="list-style-type: none"> <li>• Keep guards in place and in working order.</li> <li>• Remove any tools from bender before operating. Form habit of checking to see that all tools are removed from bender before turning it on.</li> </ul> <p>Failure to observe these warnings could result in severe injury or death.</p>

	<p><b>⚠ WARNING</b></p>
	<p>Pinch points:</p> <ul style="list-style-type: none"> <li>• Keep hands away from bending shoe, rollers, and conduit when bender is in use.</li> <li>• Support conduit when unloading. Conduit can become loose and fall if not properly supported.</li> </ul> <p>Failure to observe these warnings could result in severe injury or death.</p>

	<p><b>⚠ WARNING</b></p>
	<p>Extension cords:</p> <ul style="list-style-type: none"> <li>• Use only three-wire, 12 AWG extension cords that have three-prong grounding-type plugs and three-hole receptacles that accept the tool's plug.</li> <li>• Do not use extension cords that are longer than 30 m (100').</li> <li>• Repair or replace damaged extension cords.</li> </ul> <p>Failure to observe these warnings could result in severe injury or death.</p>

<p><b>⚠ WARNING</b></p>
<ul style="list-style-type: none"> <li>• Reduce the risk of unintentional starting. Make sure switch is in off position before plugging in.</li> <li>• Never leave tool running unattended. Turn power off. Do not leave tool until it comes to a complete stop.</li> <li>• Disconnect tools before servicing and when changing accessories such as shoes, rollers, and the like. Accidental start-up could result in serious injury.</li> </ul> <p>Failure to observe these warnings could result in severe injury or death.</p>

<p><b>⚠ WARNING</b></p>
<ul style="list-style-type: none"> <li>• Never stand on tool. Serious injury could occur if the tool is tipped.</li> <li>• Do not overreach. Keep proper footing and balance at all times.</li> </ul> <p>Failure to observe these warnings could result in severe injury or death.</p>

## **IMPORTANT SAFETY INFORMATION**

### **⚠ CAUTION**

- Conduit moves rapidly as it is bent. The path of the conduit must be clear of obstructions. Be sure clearance is adequate before starting the bend.
- Wear proper apparel. Do not wear loose clothing, gloves, neckties, rings, bracelets, or other jewelry which may get caught in moving parts. Nonslip footwear is recommended. Wear protective hair covering to contain long hair.
- Do not force rollers or alter tool. It will do the job better and safer at the rate for which it was designed.
- Use right tool. Do not force tool or attachment to do a job for which it was not designed.
- Use this tool for the manufacturer's intended purpose only. Use other than that which is instructed in this manual can result in injury or property damage.

Failure to observe these precautions may result in injury or property damage.

### **⚠ CAUTION**

- Keep work area clean. Cluttered areas and benches invite accidents.
- Keep children away. All visitors should be kept safe distance from work area.
- Make workshop kid proof with padlocks, master switches, or by removing starter keys.

Failure to observe these precautions may result in injury or property damage.

### **⚠ CAUTION**

- Inspect the bender before use. Replace worn, damaged, or missing parts with Greenlee replacement parts. A damaged or improperly assembled component could break and strike nearby personnel.
- Maintain tools with care. Keep tool clean for best and safest performance. Follow instructions for lubricating and changing accessories.
- Check damaged parts. Before further use of the tool, a guard or other part that is damaged should be carefully checked to determine that it will operate properly and perform its intended function. Check for alignment of moving parts, binding of moving parts, breakage of parts, mounting, and any other conditions that may affect its operation. A guard or other part that is damaged should be properly repaired or replaced.
- Use recommended accessories. Consult the instruction manual for recommended accessories. The use of improper accessories may cause risk of injury to persons.
- Some bender parts and accessories are heavy and may require more than one person to lift and assemble.

Failure to observe these precautions may result in injury or property damage.

*Note: Keep all decals clean and legible, and replace when necessary.*

## Service Instructions

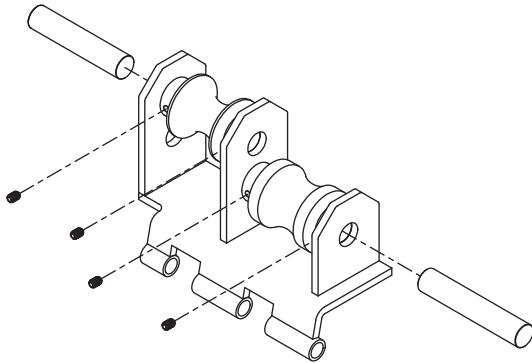

### 52047930 EMT and IMC Roller Support Assembly (for combination shoes)

1. Loosen set screws on the four sleeves.
2. Push out axle shafts.
3. Reassemble in reverse order noting the following:
  - a. Position shafts so they are flush with the plates.
  - b. Slide the sleeves fully outward before locking the set screws.

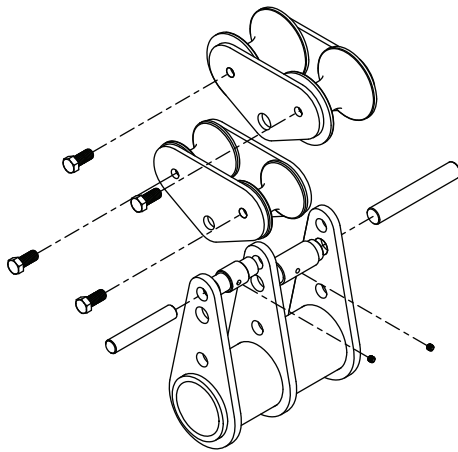

### 52055013 and 52055014 Roller Assemblies (for combination shoes)

1. Loosen the two set screws on the pivot sleeves.
2. Push out the pivot shafts and remove the roller assemblies.
3. Remove the hex bolts securing the outer plates.
4. Pull off the rollers.
5. Reassemble in reverse order noting the following:
  - a. Lubricate the roller shafts with molybdenum grease.
  - b. For 2" EMT, the smaller diameter roller goes to the left.
  - c. Position each pivot shaft so it is flush with the far surface of the middle arm.

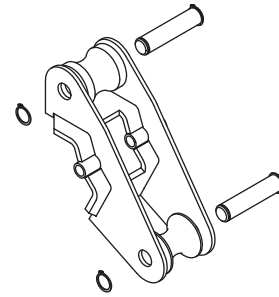

### 52055994 EMT and IMC Tail Roller Support Assembly (for single-groove shoes)

1. Remove one retaining ring from each shaft.
2. Push out the shafts and remove the rollers.
3. Reassemble in reverse order noting the following:  
Lubricate the roller shafts with molybdenum grease.

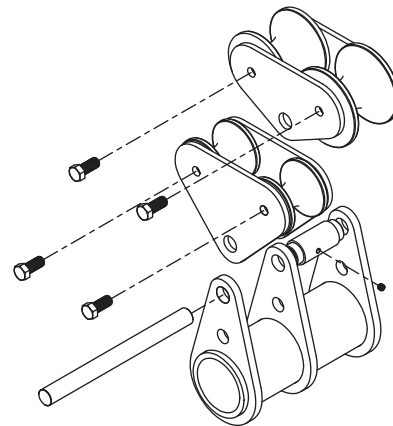

### 52044927 and 52044928 Roller Assemblies (for individual shoes)

1. Loosen the set screw on the pivot sleeves.
2. Push out the pivot shaft and remove the roller assemblies.
3. Remove the hex bolts securing the outer plates.
4. Pull off the rollers.
5. Reassemble in reverse order noting the following:
  - a. Lubricate the roller shafts with molybdenum grease.
  - b. For 2" EMT, the smaller diameter roller goes to the left.
  - c. Position the pivot shaft so an equal amount protrudes from each side of the arm weldment.

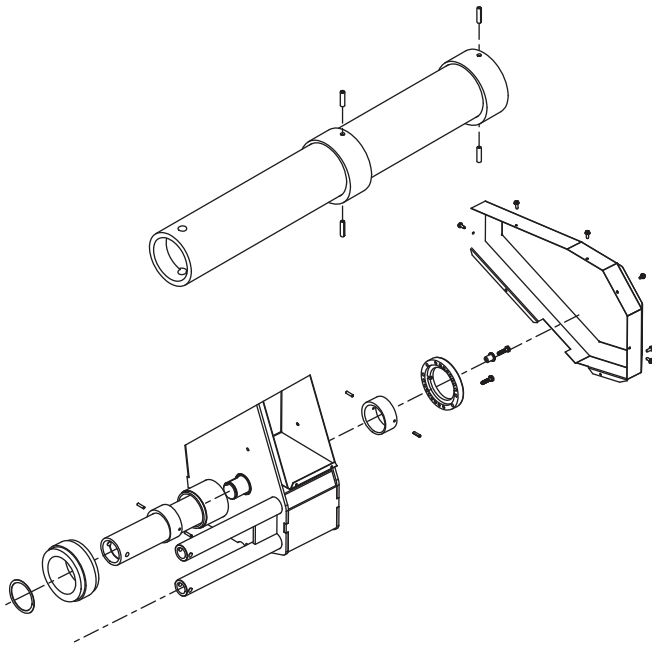
**Service Instructions (cont'd)**

**52046889 Eccentric Roller Shaft**

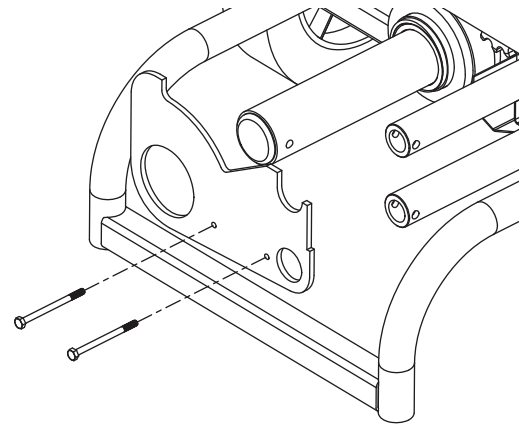
1. Remove any support rollers from shaft.
2. Remove the fiber thrust washer from the front of the shaft.
3. Remove seven screws and rear chain guard.
4. Remove two screws securing squeeze adjuster and the retainer on the top screw. Note which hole the lower screw is in.
5. Remove the adjuster.
6. Remove the rollpins by driving them into the ID of the shaft.
7. Pull out the shaft from the front and the rear eccentric from the rear.
8. Remove the front eccentric same as the rear if needed.
9. Reassemble in reverse order noting the following:
  - a. Slide the front eccentric over the shaft so the 3/16" holes are closest to the rear.
  - b. Drive the rollpins into the holes so that they do not protrude.
  - c. Lubricate the eccentrics with molybdenum grease.
  - d. Insert the shaft into the frame from the front.
  - e. Insert the rear eccentric into the frame and over the shaft so the 3/16" holes are visible.
- f. Align the holes in the eccentric and shaft together, making sure that thick part of both eccentrics are oriented together.
- g. Drive the rollpins into the holes, leaving 1/4" protruding on both sides.
- h. Orient the shaft so that the thick part of the eccentric is at 3 o'clock as viewed from the rear of the bender.
- i. Place the adjuster over the rear eccentric so that the original hole used is on the right side.
- j. Insert the hex screw through the retainer so screw head abuts the flange and screw into the top hole.
- k. Insert the second screw into the original hole and rotate the shaft until the screw can be threaded into its hole.

**Roller Stop Plate**

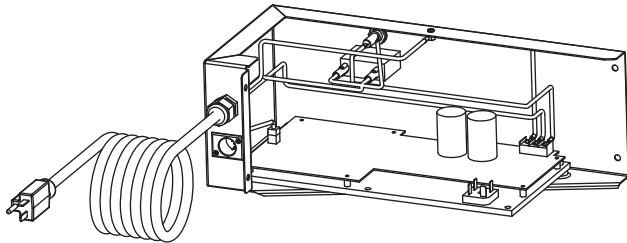
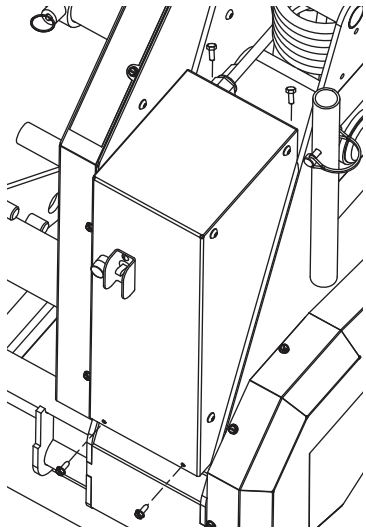
1. Remove any roller support assemblies and shoe.
2. Remove the two screws and nuts securing the roller stop plate.
3. Slide the roller stop plate off the shafts.
4. Reassemble in reverse order.

**Service Instructions (cont'd)**

**Outer Control Box**

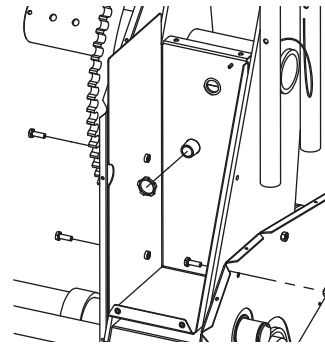
1. Remove the two screws at the bottom front of the control box (right side of bender).
2. Remove the two screws at the top rear of the control box and remove the wire cover.
3. Lift the outer control box up and outward.
4. Pull off the two motor leads from the circuit board noting their orientation.
5. Pull off the encoder cable from the circuit board (DX model only).
6. Reassemble in reverse order noting the following:  
Connect motor leads to same tabs as removed from.

**Inner Control Box**

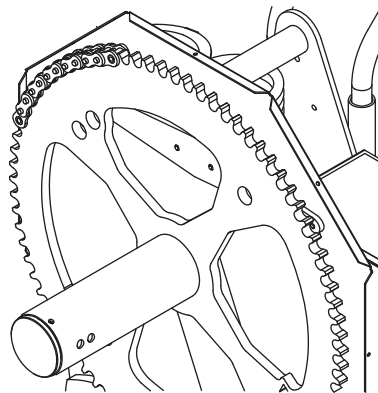
1. Remove or loosen roller stop plate (refer to previous instruction).
2. Remove outer control box (refer to previous instruction).
3. Remove seven screws and rear chain guard.
4. Remove seven screws and front chain guard.
5. Remove the conduit nut securing the SealTite conduit to the control box.
6. Remove the hex nut inside the chain guard and back out the three screws holding the control box.
7. Slide out the inner control box.
8. Reassemble in reverse order.



**Front Drive Chain**

1. Remove the roller stop plate (refer to previous instruction).
2. Remove the seven screws and the front guard.
3. Remove the plastic chain stay roller.
4. Remove the center two screws securing the chain guard stiffener along with the three screws holding the back guard, and remove the back guard.
5. Remove the master link and chain.

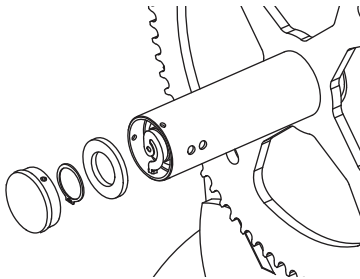

## Service Instructions (cont'd)

6. Reassemble in reverse order noting the following:
  - a. Use new cotter pins to attach the drive chain.
  - b. A new chain will be tight. Place one end of the chain at 10–11 o'clock position and wrap the remainder over the top of the big sprocket, down and around the drive sprocket, and back up to the big sprocket. Ensure that there is no slack anywhere and hold the chain against the outside of the sprocket. Force the chain into the sprocket teeth at the point where it first contacts the sprocket. (A rubber hammer may be used to persuade the chain.) While holding the chain in the sprocket teeth, fit the rest of the chain onto the sprocket. Fit the connecting link.



### Front Sprocket Assembly

1. Remove the front drive chain (refer to previous instruction).
2. Screw in the three set screws securing the spindle cap about four turns and pull off the cap.
3. Push the sprocket fully inward to gain access to the retaining ring.
4. Remove the retaining ring and large washer.
5. Slide the sprocket weldment off the bender.
6. Reassemble in reverse order noting the following:
  - a. With the sprocket pushed back against the frame, press the outer part of the torque arm into the slot of the spindle cap along the axis of the spindle. Slide the sprocket fully outward while fitting the cap into the spindle.
  - b. Do not tighten the set screws so they protrude beyond the outer diameter of the spindle.

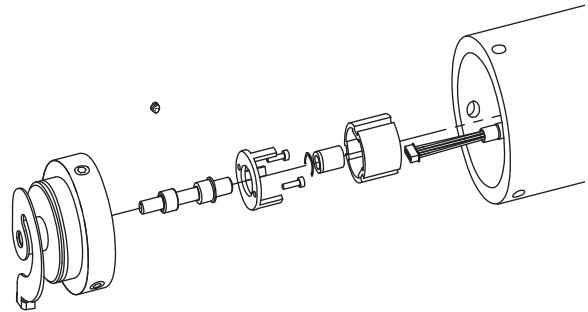

### Encoder Assembly (DX only except for encoder mount)

1. Remove front sprocket assembly (refer to previous instruction).
2. Remove the outer control box (refer to previous instruction).
3. Disconnect the encoder cable and pull cable out of inner control box.
4. Screw in the three set screws securing the encoder mount about four turns and pull out the mount complete with encoder and cable. Feed the cable through the spindle while pulling the encoder mount out.
5. Pull off the encoder cable.
6. Remove the encoder cover by prying out the plastic locking tabs.
7. Remove the two socket head screws securing the encoder case.
8. Pull the encoder magnet off the shaft.
9. Loosen the set screw securing the torque arm and remove it and the thrust washer.
10. Pull out the encoder shaft.
11. Reassemble in reverse order noting the following:
  - a. Press the magnet onto the shaft 0.002" from the base.
  - b. After securing the torque arm to the shaft, ensure that the shaft turns freely.
  - c. Pry the decorative cap from the rear end of the spindle shaft to gain access for feeding the encoder cable through the grommet to the control box.

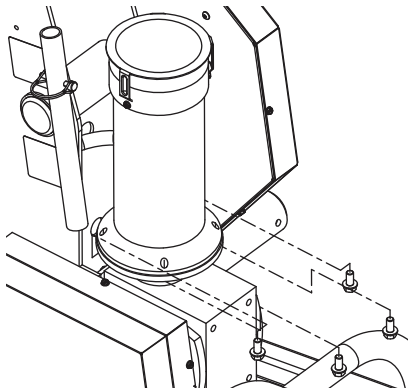
**Service Instructions (cont'd)**

**Motor**

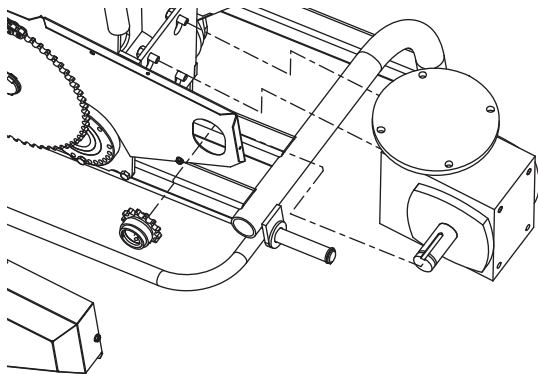
1. Remove the outer control box (refer to previous instruction).
2. Pull off the two motor leads from the circuit board noting their orientation.
3. Disconnect the SealTite connector at the motor.
4. Remove the four screws attaching the motor to the gearbox. (If access to the front inside screw is not attainable with a 7/16" flex socket or stubby wrench, access can be gained by removing the front sprocket assembly and the front guard backing plate.)
5. Pull off the motor while feeding the motor leads out of the SealTite conduit.
6. Reassemble in reverse order noting the following:
  - a. Fitting the keyway between the motor and gearbox may require staking it to keep it in place.
  - b. For easiest fitting of the SealTite connector, rotate the motor into the connector before fitting the motor mounting screws.

**Gearbox (Option 1)**

1. Remove seven screws and rear chain guard.
2. Remove connecting link and rear chain.

3. Loosen the two set screws securing the drive sprocket on the gearbox and push the sprocket inward.
4. Slide the collar inward and pry off the C clip.
5. Remove the collar and sprocket.
6. Loosen the four screws securing the gearbox to the frame.
7. Slide the gearbox downward (gravity may have already done this) and remove it by pulling the screw heads through the keyholes in the frame.
8. Reassemble in reverse order noting the following: Slide the gearbox fully upward after installing the chain and tighten the mounting screws to tension the chain.

*Note: The gearbox and motor can be removed as a unit by removing the two inner motor mounting screws and following the instructions for disconnecting the motor at the control box.*

**Gearbox (Option 2)**

1. Remove seven screws and rear chain guard.
2. Remove connecting link and rear drive chain.
3. Loosen the two set screws securing the drive sprocket on the gearbox and push the sprocket inward.
4. Slide the collar inward and pry off the C clip.
5. Remove the collar and sprocket.
6. Remove the inner chain guard (refer to previous instruction).
7. Support the gearbox, remove the four screws securing the gearbox, and remove it.
8. Reassemble in reverse order noting the following: Slide the gearbox fully upward after installing the chain and tighten the mounting screws to tension the chain.

*Note: The gearbox and motor can be removed as a unit by following the instructions for disconnecting the motor at the control box.*

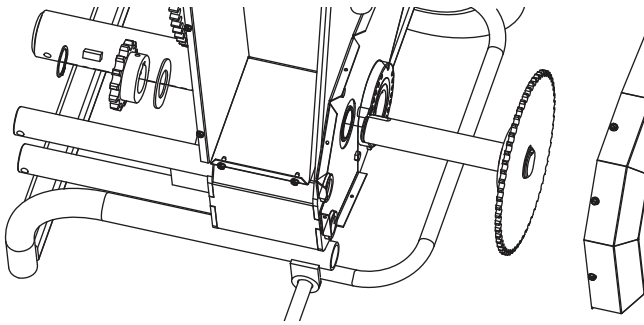
**Service Instructions (cont'd)**

**Countershaft**

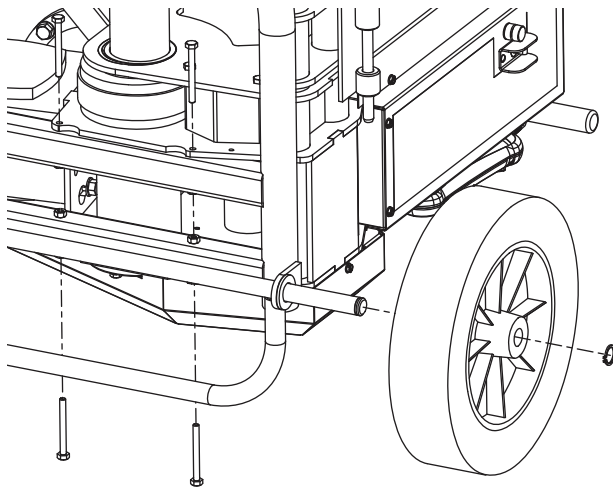
1. Remove seven screws and rear chain guard.
2. Remove connecting link and rear drive chain.
3. Remove the front drive chain (refer to previous instruction).
4. Remove a retaining ring from the countershaft.
5. Pull off the sprocket, key, and thrust washer.
6. Pull out the countershaft from the opposite side.
7. Remove the other thrust washer, sprocket, and key.
8. Reassemble in reverse order.

**Wheel Base**

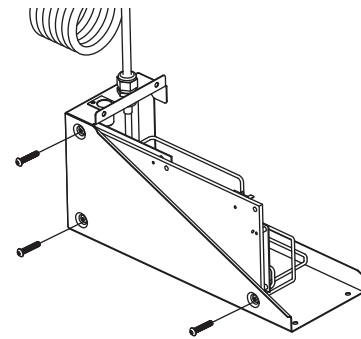
1. Lay the bender on its back so that the kick bar is resting on something that will keep the wheels in the air.
2. Remove the six screws and nuts attaching the lower base and pull it off the bender frame.
3. Remove a retaining ring from the axle.
4. Remove the wheel and axle.
5. Reassemble in reverse order.

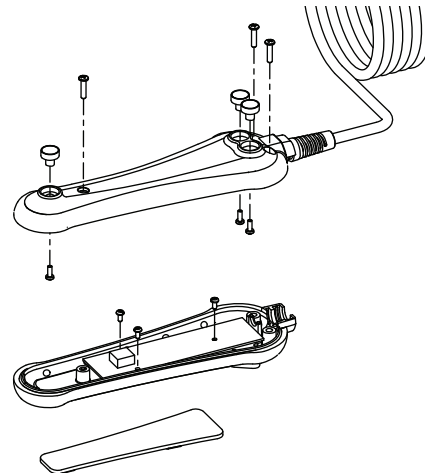

**Control Board Assembly**

1. Remove outer control box (refer to previous instruction).
2. Disconnect the power connections to the board from the circuit breaker and power cord.
3. Disconnect the pendant receptacle cable.
4. Remove the three button head screws attaching the control board assembly to the enclosure, and remove the control board assembly and the three spacers.
5. Reassemble in reverse order.

**Pendant Switch**

1. Remove three screws holding the housing halves together and separate.
2. Unplug the pendant cord from the circuit board and remove strain relief from housing.
3. Remove the three screws and the circuit board.
4. Unplug the keypad from the circuit board.
5. Remove the three screws from the bottom housing to remove the magnets.
6. Peel the keypad membrane from the top housing.
7. Reassemble in reverse order noting the following:  
Clean all residue from the mounting surface.

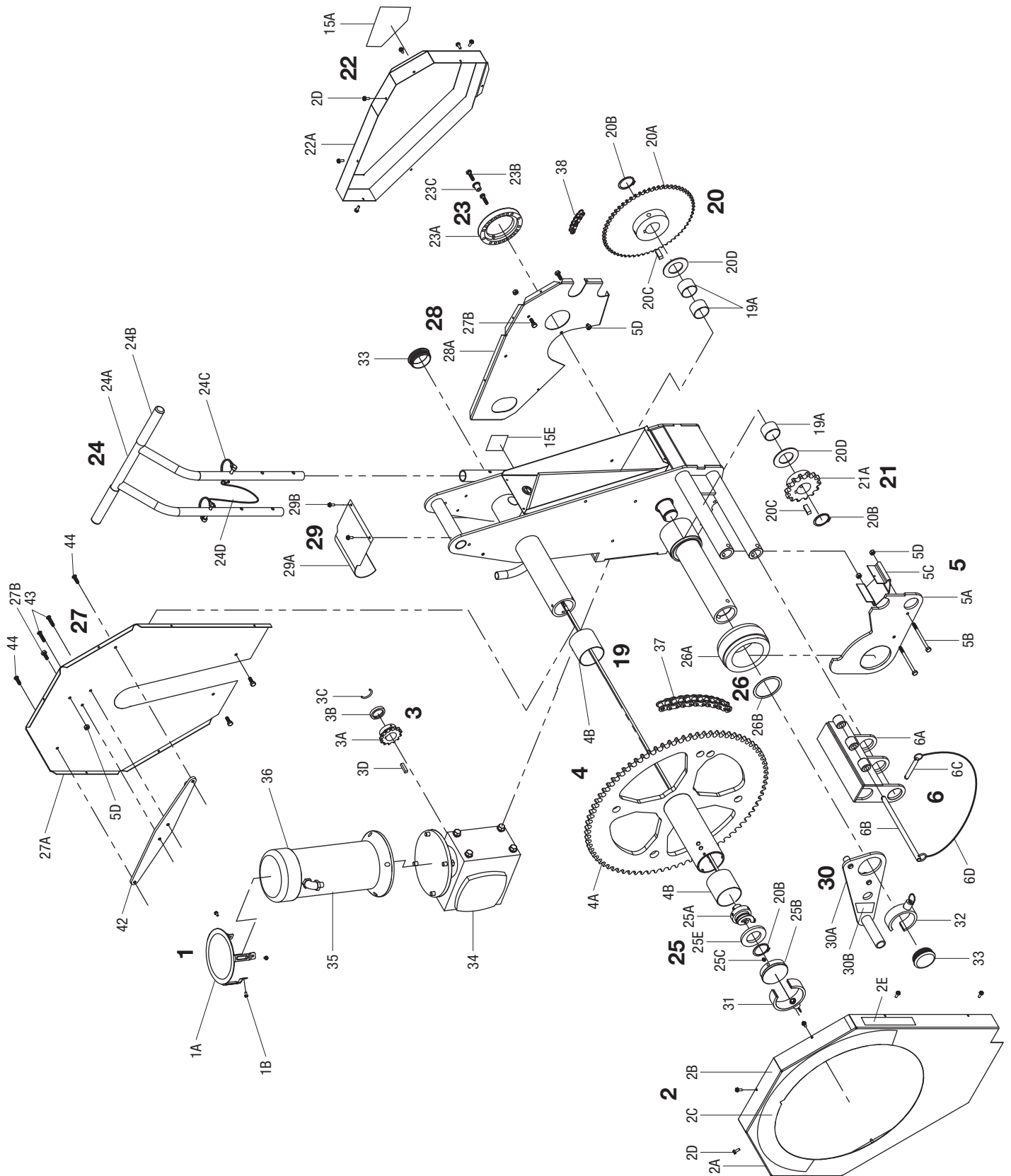
**Illustration**



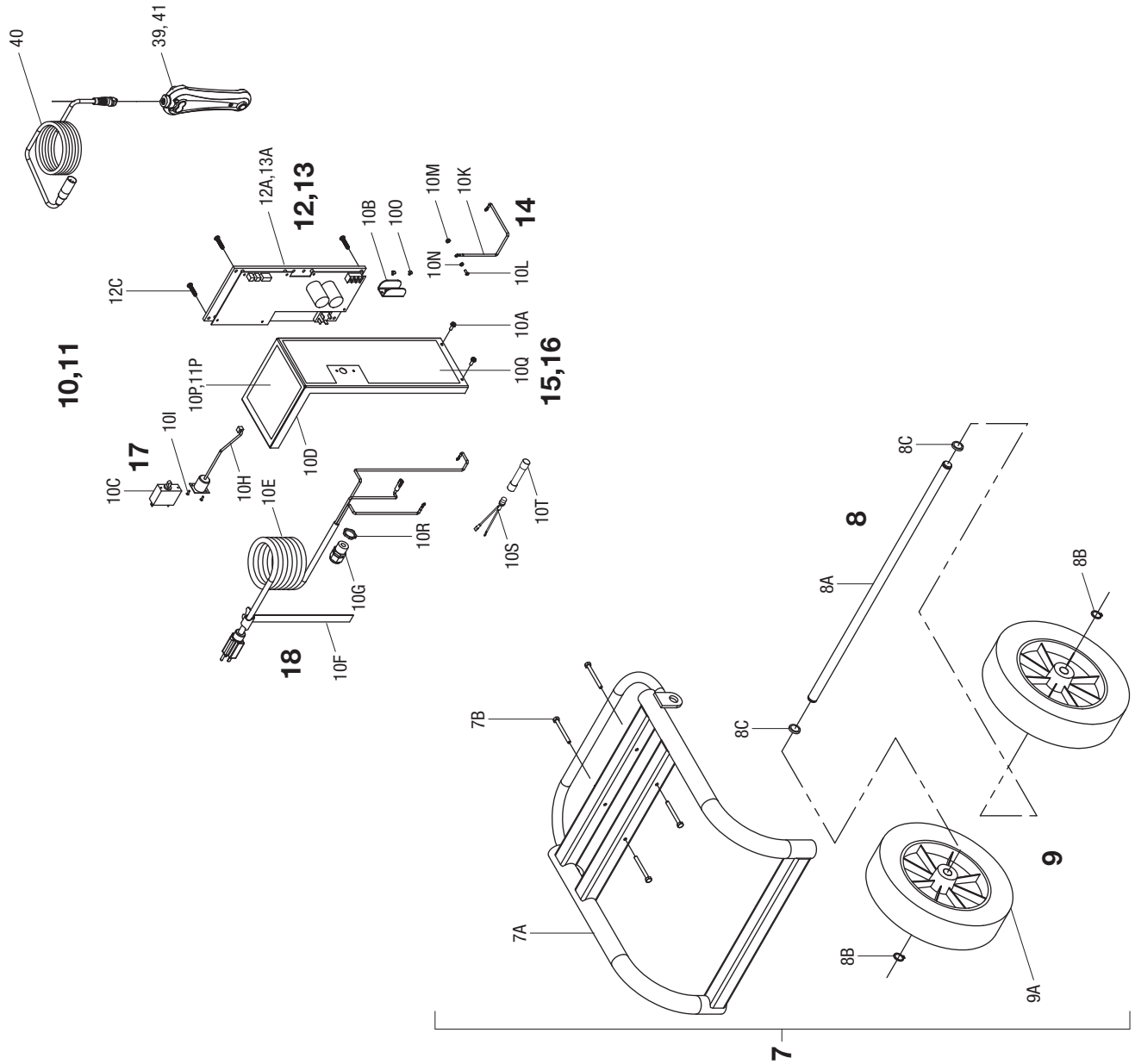

**Parts List**

Group	Key	Part No.	Description	Qty
1		<b>52056409</b>	<b>Cap kit, motor</b>	
	1A		Cap, motor.....	1
	1B		Screw, #10-32 x 5/16, hex head slotted.....	3
2		<b>52056410</b>	<b>Guard kit, front main sprocket</b>	
	2A		Guard, front chain.....	1
	2B		Decal, stub and offset.....	1
	2C		Decal, protractor.....	1
	2D		Screw, #10-16 x 1/2, thread-forming.....	7
	2E		Decal, EMT, IMC, PVC bending chart.....	1
3		<b>52056411</b>	<b>Sprocket kit, gearbox output</b>	
	3A		Sprocket, #40-13 tooth.....	1
	3B		Collar.....	1
	3C		Ring, retaining, round.....	1
	3D		Key, square, .249 x 1.06.....	1
4		<b>52056412</b>	<b>Sprocket kit, main</b>	
	4A		Sprocket weldment.....	1
	4B		Bearing, fiberglide.....	2
5		<b>52056413</b>	<b>Plate kit, roller stop</b>	
	5A		Plate, roller stop.....	1
	5B		Screw, cap, 1/4-20 x 3.500 hex head.....	2
	5C		Guard, lower spacer.....	1
	5D		Nut, hex, 1/4-20.....	2
6		<b>52056414</b>	<b>Adapter kit, roller</b>	
	6A		Adapter assembly.....	1
	6B		Pin, hitch, .437 x 8.10.....	1
	6C		Pin, hitch, short.....	1
	6D		Lanyard.....	1
7		<b>52056415</b>	<b>Base kit</b>	
	7A		Carriage weldment.....	1
	7B		Bolt, 1/4-20 x 2.25.....	4
	8A		Axle.....	1
	8B		Ring, retaining, .750 Truarc #5160 EX.....	2
	8C		Washer, .81 x 1.50 x .14.....	2
	9A		Wheel, rubber (12 x 3).....	2
8		<b>52056416</b>	<b>Axle kit, wheel</b>	
	8A		Axle.....	1
	8B		Ring, retaining, .750 Truarc #5160 EX.....	2
	8C		Washer, .81 x 1.50 x .14.....	2
9		<b>52056417</b>	<b>Replacement kit, wheel</b>	
	9A		Wheel, rubber (12 x 3).....	2
10		<b>52056418</b>	<b>Box kit, control (555DX) for 120 volt bender</b>	
		<b>52061321</b>	<b>Box kit, control (555DX-22) for 220 volt bender</b>	
	10A		Screw, #10-32 x 5/16, hex head slotted.....	2
	10B		Guard, switch.....	1
	10C	91863856	Breaker, circuit (555DX) for 120 volt bender.....	1
		52060436	Breaker, circuit (555DX-22) for 220 volt bender.....	1
	10D		Cover, box.....	1
	10E		Power cord unit.....	1
10F		Strap, velcro.....	1	

**Parts List (cont'd)**

Group	Key	Part No.	Description	Qty
	10G		Bushing, strain relief.....	1
	10H		Receptacle unit, standard .....	1
	10I		Screw, 4-40 x .50, flat head, Taptite II.....	2
	10K		Wire assembly (ground) .....	1
	10L		Screw, #6-32 x 3/8, phillips pan head machine .....	1
	10M		Nut, hex, #6-32 lock, .178 thk zp.....	1
	10N		Washer, #6, star, intern, CZ/ST .....	2
	10O		Screw, #6-32 x 1/4, phillips pan head.....	2
	10P		Decal, operating instructions .....	1
	10Q		Decal, identification .....	1
	10R		Nut, lock-1/2 conduit.....	1
	10S		Holder, fuse .....	1
	10T	52056934	Fuse (package consisting of 5 fuses).....	1
	12A		Control board assembly.....	1
	12C		Screw, cap, 1/4-20 x .50, btn skt head.....	3
<b>11</b>		<b>52056419</b>	<b>Box kit, control (555CX)</b>	
	10A		Screw, #10-32 x 5/16, hex head slotted .....	2
	10B		Guard, switch .....	1
	10C	91863856	Breaker, circuit .....	1
	10D		Cover, box .....	1
	10E		Power cord unit .....	1
	10F		Strap, velcro.....	1
	10G		Bushing, strain relief.....	1
	10H		Receptacle unit, standard .....	1
	10I		Screw, 4-40 x .50, flat head, Taptite II.....	2
	10K		Wire assembly (ground) .....	1
	10L		Screw, #6-32 x 3/8, phillips pan head machine .....	1
	10M		Nut, hex, #6-32 lock, .178 thk zp.....	1
	10N		Washer, #6, star, intern, CZ/ST .....	2
	10O		Screw, #6-32 x 1/4 slotted, round head.....	2
	11P		Decal, operating instructions .....	1
	10Q		Decal, identification .....	1
	10R		Nut, lock-1/2 conduit.....	1
	10S		Holder, fuse .....	1
	10T	52056934	Fuse (package consisting of 5 fuses).....	1
	13A		Control board assembly (555CX) .....	1
	12C		Screw, cap, 1/4-20 x .50, btn skt head.....	3
<b>12</b>		<b>52056420</b>	<b>Assembly kit, control board (555DX) for 120 volt bender</b>	
		<b>52061322</b>	<b>Assembly kit, control board (555DX-22) for 220 volt bender</b>	
	12A		Control board assembly.....	1
	12C		Screw, cap, 1/4-20 x .50, btn skt head.....	3
<b>13</b>		<b>52056421</b>	<b>Assembly kit, control board (555CX)</b>	
	13A		Control board assembly.....	1
	12C		Screw, cap, 1/4-20 x .50, btn skt head.....	3
<b>14</b>		<b>52056422</b>	<b>Screw kit, ground</b>	
	10K		Wire assembly (ground) .....	1
	10L		Screw, #6-32 x 3/8, phillips pan head machine .....	1
	10M		Nut, hex, #6-32 lock, .178 thk zp.....	1
	10N		Washer, #6, star, intern, CZ/ST .....	2

**Parts List (cont'd)**

Group	Key	Part No.	Description	Qty
15		<b>52056423</b>	<b>Decal kit (555DX and 555DX-22)</b>	
	15A		Decal, squeeze adjustment.....	1
	2C		Decal, protractor .....	1
	10P		Decal, operating instructions .....	1
	10Q		Decal, identification.....	1
	15E		Decal, lifting instructions.....	1
	30B		Decal, engage rollers .....	1
	2B		Decal, stub and offset dimensions.....	1
	2E		Decal, EMT, IMC, PVC bending chart .....	1
16		<b>52056424</b>	<b>Decal kit (555CX)</b>	
	15A		Decal, squeeze adjustment.....	1
	2C		Decal, protractor .....	1
	11P		Decal, operating instructions .....	1
	10Q		Decal, identification.....	1
	15E		Decal, lifting instructions.....	1
	30B		Decal, engage rollers .....	1
	2B		Decal, stub and offset dimensions.....	1
	2E		Decal, EMT, IMC, PVC bending chart .....	1
17	10C	<b>91863856</b>	<b>Breaker, circuit (for 120 volt bender)</b> .....	1
		<b>52060436</b>	<b>Breaker, circuit (for 220 volt bender)</b> .....	1
18		<b>52056426</b>	<b>Cord unit, power (for 120 volt bender)</b>	
		<b>52061323</b>	<b>Cord unit, power (for 220 volt bender)</b>	
	10E		Power cord unit.....	1
	10G		Bushing, strain relief.....	1
	10F		Strap, velcro.....	1
		10R	Nut, lock-1/2 conduit.....	1
19		<b>52056427</b>	<b>Bearing kit</b>	
	19A		Bearing, phenolic .....	2
		4B	Bearing, fiberglide .....	2
20		<b>52056428</b>	<b>Sprocket kit, #40B60</b>	
	20A		Sprocket, #40 60T (includes 2 set screws) .....	1
	20B		Ring, retaining, 1.50 Truarc #5100 EX.....	1
	20C		Key, countershaft .....	1
		20D	Bearing, thrust, 1.50 x 2.62 x .093.....	1
21		<b>52056429</b>	<b>Sprocket kit, #60BS14</b>	
	21A		Sprocket, #60 14T (includes 2 set screws) .....	1
	20B		Ring, retaining, 1.50 Truarc #5100 EX.....	1
	20C		Key, countershaft .....	1
		20D	Bearing, thrust, 1.50 x 2.62 x .093.....	1
22		<b>52056430</b>	<b>Guard kit, rear chain</b>	
	22A		Guard, rear .....	1
	2D		Screw, thread-forming, #10-16 x .50 .....	7
		15A	Decal, squeeze adjustment.....	1
23		<b>52056431</b>	<b>Adjustment kit, squeeze cam</b>	
	23A		Adjuster, squeeze.....	1
	23B		Screw, cap, 1/4-20 x 1.00 hex head .....	2
		23C	Guide, adjuster.....	1



**Parts List (cont'd)**

Group	Key	Part No.	Description	Qty
<b>24</b>		<b>52056432</b>	<b>Handle kit, replacement</b>	
	24A		Handle weldment .....	1
	24B		Grip .....	2
	24C		Pin, safety snap.....	2
	24D		Lanyard .....	1
<b>25</b>		<b>52056433</b>	<b>Encoder kit</b>	
	25A		Encoder, sub-assembly .....	1
	25B		Cap, encoder .....	1
	25C		Screw, set, 1/4-20 x .375 skt .....	3
	20B		Ring, retaining, 1.50 Truarc #5100 EX.....	1
	25E		Retainer.....	1
<b>26</b>		<b>52056434</b>	<b>Idler kit, chain</b>	
	26A		Stay, chain.....	1
	26B		Washer, flat, 2.50 x 3.00 x .031 fiber.....	1
<b>27</b>		<b>52056435</b>	<b>Rear guard kit, main sprocket</b>	
	27A		Guard, chain, back.....	1
	27B		Screw, cap, 1/4-20 x .750 hex head .....	3
	5D		Nut, hex, 1/4-20 .....	1
<b>28</b>		<b>52056436</b>	<b>Back guard kit, rear chain</b>	
	28A		Guard, back, rear .....	1
	5D		Nut, hex, 1/4-20 .....	2
	27B		Screw, #10-32 x 5/16, hex head slotted .....	3
<b>29</b>		<b>52056437</b>	<b>Guard kit, top frame</b>	
	29A		Cover, wire .....	1
	29B		Screw, #10-32 x 5/16, hex head slotted .....	2
<b>30</b>		<b>52056438</b>	<b>Pedal, roller</b>	
	30A		Foot pedal weldment .....	1
	30B		Decal, engage rollers .....	1
	<b>Individual items</b>			
	31	52044571	Lock collar assembly, large.....	1
	32	52044514	Lock collar assembly, small .....	1
	33	52047945	Cap, plastic 2" .....	2
	34	90523881	Reductor .....	1
	35	52057563	Motor, 120V, bender.....	1
		52057908	Motor, 220V, bender.....	1
	36	91864208	Brushes (for 120V motor).....	2
	37	90542509	Chain, roller. #60 (92 pitches) with connecting link.....	1
	38	52055855	Chain, #40 (86 pitches) with connecting link .....	1
	39	52054398	Switch unit, pendant (555DX and 555DX-22) .....	1
	40	52054423	Cord assembly, pendant.....	1
	41	52055061	Switch unit, pendant (555CX) .....	1
	42		Bar, guard stiffener.....	1
	43		Screw, 1/4-20 x 5/8 button head cap .....	2
	44		Screw, 1/4-20 x 3/8 button head cap .....	2

### Bending Attachments

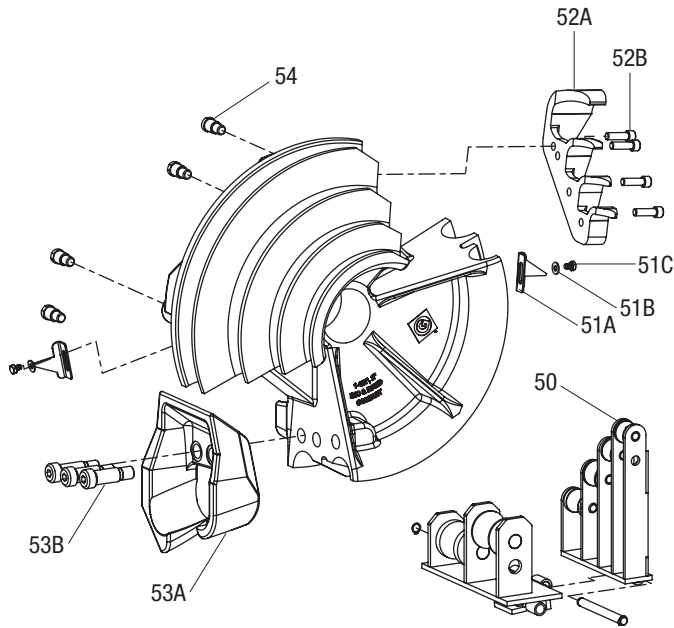
**28008 BENDING SHOE AND ROLLER SUPPORT**
**1/2" to 2" Rigid Conduit**  
**1/2" to 1-1/4" IMC Conduit**

Key	Part No.	Description	Qty
	52066935	Shoe unit, 1/2"-2" rigid/IMC.....	1
	52066936	Roller support unit, 1/2"-2" rigid .....	1
50	52066937	Roller support, 1/2"-1-1/4".....	1
<b>51</b>	<b>52065278</b>	<b>Pointer kit</b> (includes one each 51A-51C)	
51A		Point.....	2
51B		Washer, 1/4" standard .....	2
51C		Screw, 1/4-20 x 3/8 hex hd cap.....	2
<b>52</b>	<b>52065279</b>	<b>Hook kit, 1/2"-1-1/4" rigid/IMC</b>	
52A		Hook, 1/2"-1-1/4" rigid/IMC.....	1
52B		Screw, 3/8-16 x 1-1/4 skt hd cap .....	4
<b>53</b>	<b>52065280</b>	<b>Hook kit, 1-1/2"-2" rigid/IMC</b>	
53A		Hook, 1-1/2"-2" rigid/IMC .....	1
53B		Shoulder screw, ø.75 x 1.50 x 5/8-11...3	3
54	52066933	Drive pin.....	4

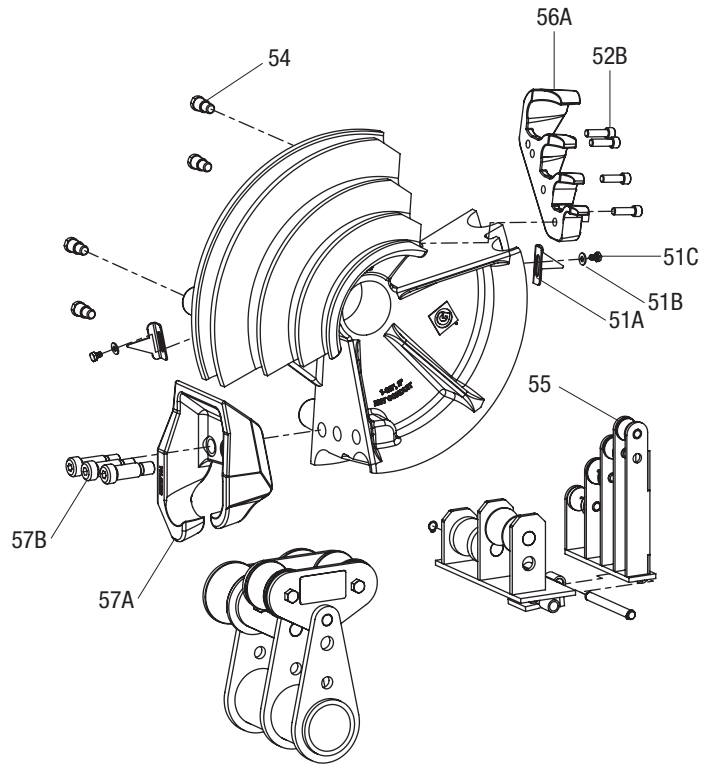
**13934 BENDING SHOE AND ROLLER SUPPORT**
**1/2" to 2" EMT Conduit**

Key	Part No.	Description	Qty
	52066931	Shoe unit, 1/2"-2" EMT .....	1
	52066938	Squeeze rollers, 1-1/2"-2" EMT .....	1
	52066961	Roller support unit, 1/2"-2" EMT .....	1
55	52066934	Roller support, 1/2"-1-1/4" EMT .....	1
<b>51</b>	<b>52065278</b>	<b>Pointer kit</b> (includes one each 51A-51C)	
51A		Point.....	2
51B		Washer, 1/4" standard .....	2
51C		Screw, 1/4-20 x 3/8 hex hd cap.....	2
<b>56</b>	<b>52065321</b>	<b>Hook kit, 1/2"-1-1/4" EMT</b>	
56A		Hook, 1/2"-1-1/4" EMT .....	1
56B		Screw, 3/8-16 x 1-1/4 skt hd cap .....	4
<b>57</b>	<b>52065322</b>	<b>Hook kit, 1-1/2"-2" EMT</b>	
57A		Hook, 1-1/2"-2" EMT.....	1
57B		Shoulder screw, ø.75 x 1.50 x 5/8-11...3	3
54	52066933	Drive pin.....	4

## Bending Attachments

### 12586 PVC BENDING SHOE AND ROLLER SUPPORT

1/2" to 2" 40 Mil PVC-Coated Rigid Conduit

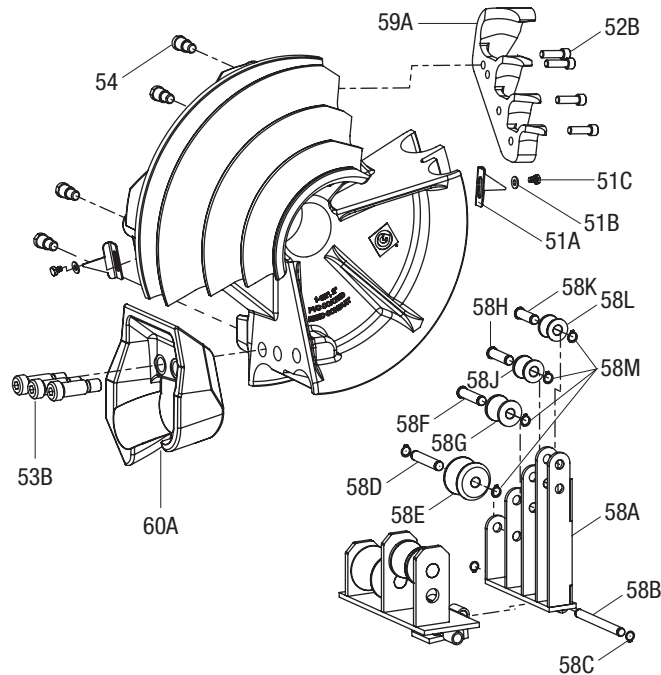

Key	Part No.	Description	Qty
	52066939	Shoe unit, 1/2"-2" PVC-coated rigid	
	52066940	Roller support unit, 1/2"-2"	
<b>58</b>	<b>52065272</b>	<b>Roller support, 1/2"-1-1/4"</b>	
58A		Support weldment .....	1
58B		Pivot pin .....	1
58C		Retaining ring, Truarc #5160-42 EX .....	2
58D		Axle, 1-1/4" roller .....	1
58E		Roller, 1-1/4" .....	1
58F		Axle, 1" roller .....	1
58G		Roller, 1" .....	1
58H		Axle, 3/4" roller .....	1
58J		Roller, 3/4" .....	1
58K		Axle, 1/2" roller .....	1
58L		Roller, 1/2" .....	1
58M		Retaining ring, Truarc #5160-50 EX .....	5

Key	Part No.	Description	Qty
<b>51</b>	<b>52065278</b>	<b>Pointer kit (includes one each 51A-51C)</b>	
51A		Point .....	2
51B		Washer, 1/4" standard .....	2
51C		Screw, 1/4-20 x 3/8 hex hd cap .....	2
<b>59</b>	<b>52065323</b>	<b>Hook kit, 1/2"-1-1/4" PVC</b>	
59A		Hook, 1/2"-1-1/4" PVC .....	1
52B		Screw, 3/8-16 x 1-1/4 skt hd cap .....	4
<b>60</b>	<b>52065324</b>	<b>Hook kit, 1-1/2"-2" PVC</b>	
60A		Hook, 1-1/2"-2" PVC .....	1
53B		Shoulder screw, ø.75 x 1.50 x 5/8-11 ...	3
54	52066933	Drive pin .....	4

**Wiring Diagrams**

**555CX**

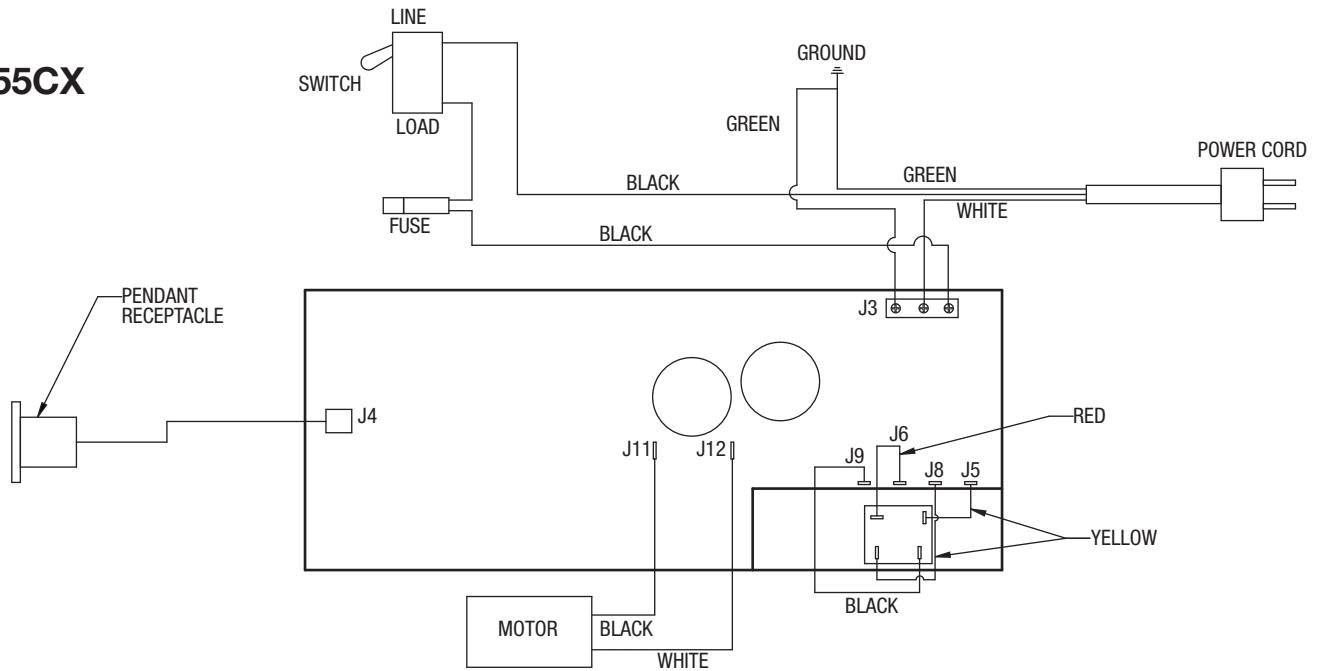

**555DX and 555DX-22**

