

# INSTRUCTION MANUAL

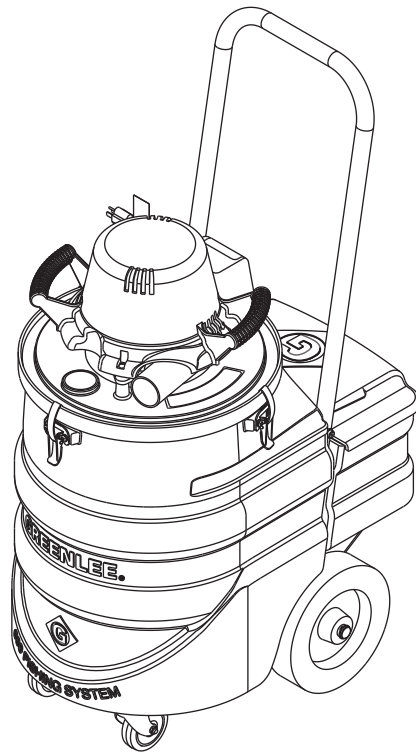

## 690 Power Fishing System



**Read and understand** all of the instructions and safety information in this manual before operating or servicing this tool.

Register this product at [www.greenlee.com](http://www.greenlee.com)

## Table of Contents

Description .....	2
Safety .....	2
Purpose of this Manual .....	2
Important Safety Information .....	3-4
Grounding Instructions .....	4
Identification .....	5
Specifications .....	5
Assembly .....	6
Operation .....	6-8
Maintenance .....	8-9
Troubleshooting .....	9
Illustration .....	10
Parts List .....	11
Wiring Diagram .....	12

## Description

The Greenlee 690 Power Fishing System is intended to “fish,” or route, nylon fishing line through 1/2" to 4" conduit. Optional accessories are also available for fishing through 5" and 6" conduit, and for clean-up vacuuming.

This tool is intended for commercial use.

## Safety

Safety is essential in the use and maintenance of Greenlee tools and equipment. This instruction manual and any markings on the tool provide information for avoiding hazards and unsafe practices related to the use of this tool. Observe all of the safety information provided.

## Purpose of this Manual

This manual is intended to familiarize personnel with the safe operation and maintenance procedures for the Greenlee 690 Power Fishing System.

Keep this manual available to all personnel.

Replacement manuals are available upon request at no charge at [www.greenlee.com](http://www.greenlee.com).



**Do not discard this product or throw away!**

For recycling information, go to [www.greenlee.com](http://www.greenlee.com).

All specifications are nominal and may change as design improvements occur. Greenlee Textron Inc. shall not be liable for damages resulting from misapplication or misuse of its products. Mighty Mouser is a registered trademark of Greenlee Textron Inc.

# **KEEP THIS MANUAL**

## IMPORTANT SAFETY INFORMATION



### SAFETY ALERT SYMBOL

This symbol is used to call your attention to hazards or unsafe practices which could result in an injury or property damage. The signal word, defined below, indicates the severity of the hazard. The message after the signal word provides information for preventing or avoiding the hazard.

### ⚠️ DANGER

Immediate hazards which, if not avoided, **WILL** result in severe injury or death.

### ⚠️ WARNING

Hazards which, if not avoided, **COULD** result in severe injury or death.

### ⚠️ CAUTION

Hazards or unsafe practices which, if not avoided, **MAY** result in injury or property damage.



### ⚠️ DANGER

**Read all instructions before using.**

Failure to observe this warning will result in severe injury or death.



### ⚠️ DANGER

Do not use this tool in a hazardous environment, or use this tool to vacuum up anything hazardous. Hazards include flammable liquids, gases, or other materials. Such use can result in a fire or explosion.

Failure to observe this warning will result in severe injury or death.

**SAVE THESE INSTRUCTIONS**

### ⚠️ WARNING

- Do not allow to be used as a toy. Close attention is necessary when used by or near children.
- Use only as described in this manual. Use only manufacturer's recommended attachments.
- Do not put any object into openings. Do not use with any opening blocked; keep free of dust and debris that may reduce air flow.
- Turn power OFF before unplugging.
- Use extra care when cleaning on stairs.
- Keep loose clothing and all parts of the body away from openings and moving parts.

Failure to observe these warnings could result in severe injury or death.

### ⚠️ WARNING

Electric shock hazard:

- Do not leave unit unattended when plugged in. Unplug from receptacle when not in use and before servicing.
- For indoor use only.
- Do not expose to rain. Store indoors.
- Do not handle plug or vacuum/blower unit with wet hands.
- Do not use with a damaged cord or plug. If the vacuum/blower is not working as it should, if it has been dropped, damaged, left outdoors or dropped into water, send it to an authorized Greenlee service center.
- Do not pull or carry by cord, use the cord as a handle, close a door on the cord, run over the cord, or pull the cord around sharp edges or corners. Keep the cord away from heated surfaces.
- Do not unplug by pulling on the cord. To unplug, grasp and pull the plug — not the cord.
- Connect to a properly grounded receptacle only. Refer to "Grounding Instructions."
- Disconnect from power before servicing.



Failure to observe these warnings could result in severe injury or death.

## IMPORTANT SAFETY INFORMATION

	<b>⚠ WARNING</b>
	<p>Do not vacuum or blow burning or toxic materials such as carcinogens, asbestos, pesticides or heavy metals.</p>

	<b>⚠ WARNING</b>
	<ul style="list-style-type: none"> <li>• Wear eye protection and a dust mask when operating or servicing this tool.</li> <li>• Piston and debris will exit the conduit at high speed. Attach the warning tag at the exit end of the conduit before blowing a piston through the conduit.</li> </ul> <p>Failure to wear eye protection could result in serious eye injury from flying debris.</p>

<b>⚠ WARNING</b>
<ul style="list-style-type: none"> <li>• Do not use without a clean filter in place. Using the vacuum/blower with a clogged, damaged or missing filter will cause damage to the motor.</li> <li>• Do not vacuum up anything that is burning or smoking, such as cigarettes, matches or hot ashes.</li> </ul> <p>Failure to observe these warnings could result in severe injury or death.</p>

*Note: Keep all decals clean and legible, and replace when necessary.*

### SAVE THESE INSTRUCTIONS

## Grounding Instructions

	<b>⚠ WARNING</b>
	<p>Electric shock hazard:</p> <ul style="list-style-type: none"> <li>• Do not modify the plug provided with the tool.</li> <li>• Connect this tool to a grounded receptacle on a 15-amp GFCI-protected circuit.</li> </ul> <p>Failure to observe these warnings could result in severe injury or death.</p>

### NEMA 5-15

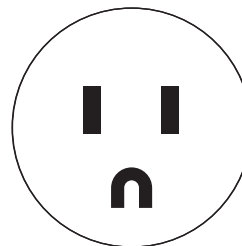

Plug

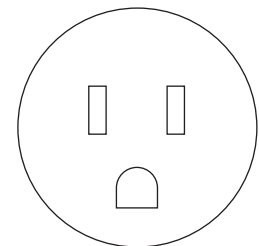

Receptacle

This tool must be grounded. In the event of a malfunction or breakdown, an electrical ground provides a path of least resistance for the electric current. This path of least resistance is intended to reduce the risk of electric shock.

This tool's electric cord has a grounding conductor and a grounding plug as shown. Do not modify the plug. Connect the plug to a corresponding GFCI-protected receptacle that is properly installed and grounded in accordance with all national and local codes and ordinances.

Do not use an adapter.

**Identification**

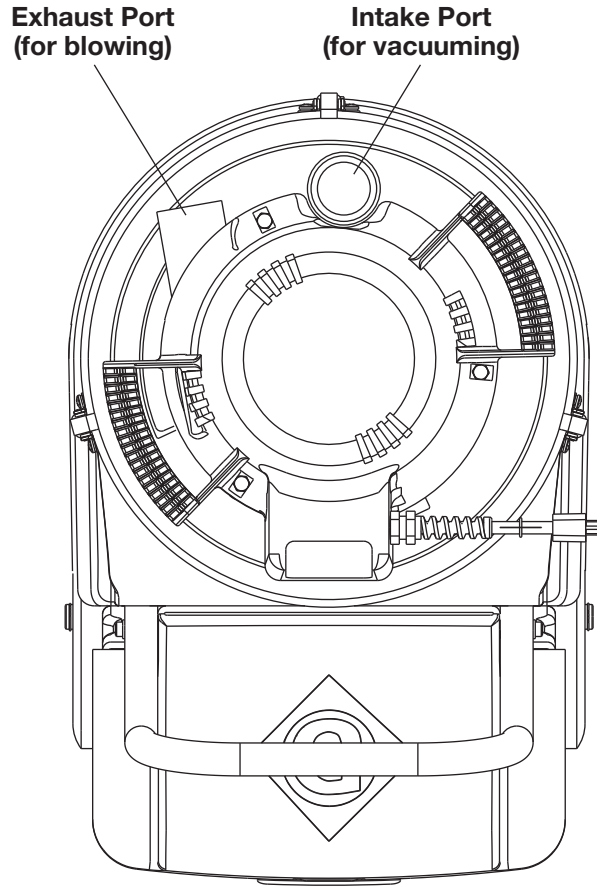

**Specifications**

Motor .....	12 amps / 12 VAC / 60 Hz
Pressure	
Blower .....	4 psi (0.275 bar)
Vacuum	
Column of Water .....	112.8" (2.9 m)
Column of Mercury .....	8.3" (211 mm)
Air Flow .....	120 CFM (3.4 m <sup>3</sup> /min)
Tank Capacity (liquid) .....	12 U.S. gal (41 l)
Mass / Weight .....	52 lb (24 kg)

## Assembly

Refer to the “Illustration” and “Parts List” sections of this manual.

1. Attach the handle to the tank by using four screws (44) and four washers (43). Make sure to leave enough space for the storage box. **DO NOT** screw the screws tight.

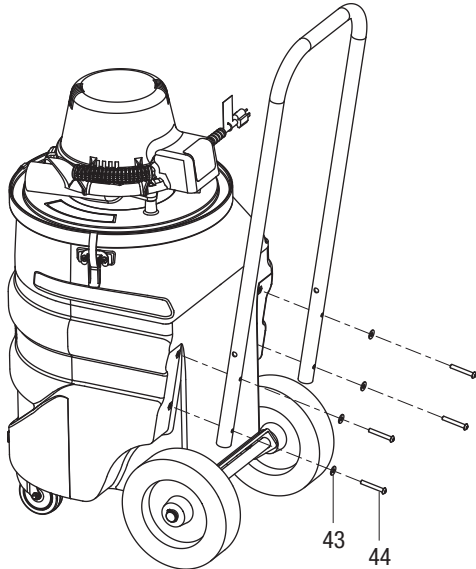

2. Attach the storage box to the tank by positioning the box over the screws and washers from the handle and sliding the box down firmly until it locks into place. If preferred, tighten the screws to squeeze the storage box. Be careful **NOT** to overtighten.

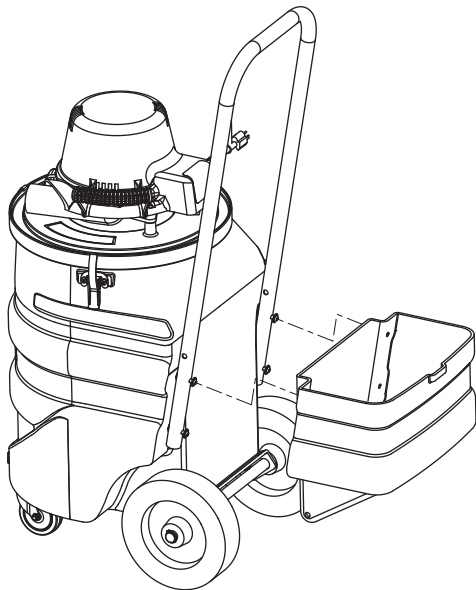

3. Attach the storage box lid to the handle by using two shoulder screws (47) and two nuts (48).

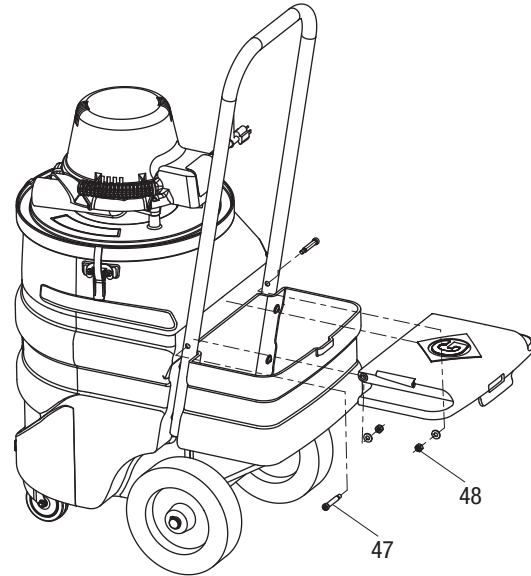

## Operation

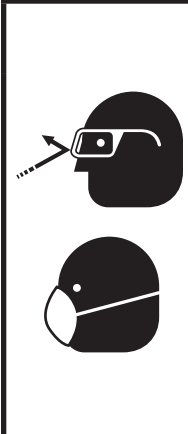
	<p style="text-align: center;"><b>⚠ WARNING</b></p> <ul style="list-style-type: none"> <li>• Wear eye protection and a dust mask when operating or servicing this tool.</li> <li>• Piston and debris will exit the conduit at high speed. Attach the warning tag at the exit end of the conduit before blowing a piston through the conduit.</li> </ul> <p>Failure to wear eye protection could result in serious eye injury from flying debris.</p>
---	--

Use the 690 alone, or combine it with a 592 Mighty Mouser® Blow Gun Kit as shown here.

### OPERATING TIPS

- When fishing through IMC or rigid, blowing is generally more efficient than vacuuming.
- When fishing through EMT, vacuuming is the better method. EMT connections are not airtight, and a piston that is blown through might not reach the exit end of the conduit run.
- Two fishing lines can be vacuumed in at the same time, if desired. Leave one line in the conduit to pull additional wire into the conduit after the initial installation.

**Operation (cont'd)**

**VACUUMING**

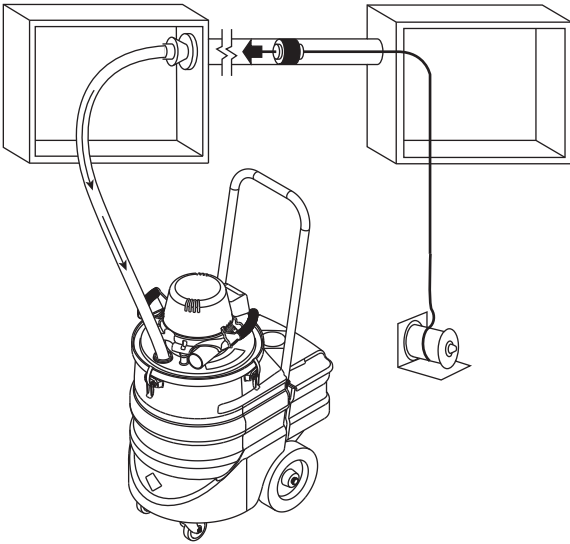

**BLOWING WITH OPTIONAL 592 MIGHTY MOUSER® BLOW GUN KIT**

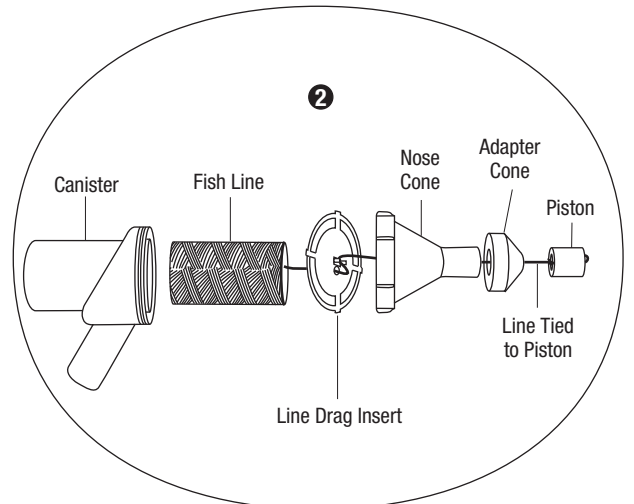

**BLOWING**

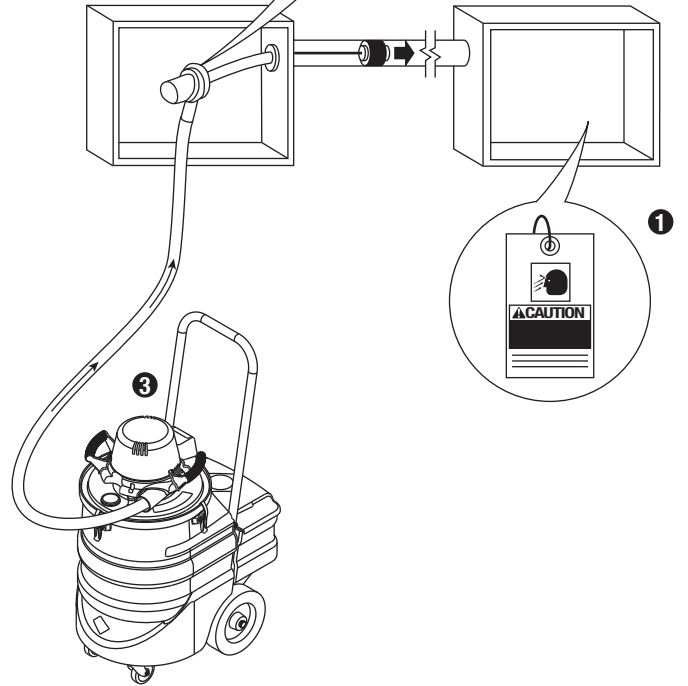
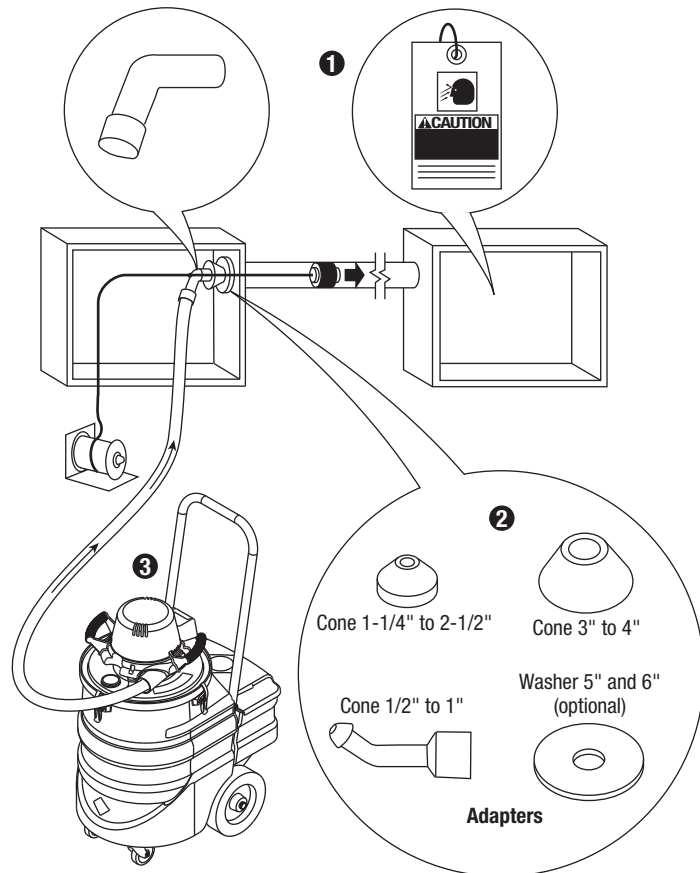



## Operation (cont'd)

### CLEAN-UP VACUUMING

	<b>⚠ WARNING</b>
	Do not vacuum or blow burning or toxic materials such as carcinogens, asbestos, pesticides or heavy metals.

	<b>⚠ WARNING</b>
	Wear eye protection and a dust mask when operating or servicing this tool.  Failure to wear eye protection could result in serious eye injury from flying debris.

<b>⚠ WARNING</b>
Use extra care when cleaning on stairs. Failure to observe this warning could result in severe injury or death.

<b>⚠ WARNING</b>
<ul style="list-style-type: none"> <li>Do not use without a clean filter in place. Using the vacuum/blower with a clogged, damaged or missing filter will cause damage to the motor.</li> <li>Do not vacuum up anything that is burning or smoking, such as cigarettes, matches or hot ashes.</li> </ul> <p>Failure to observe these warnings could result in severe injury or death.</p>

### Wet Pickup

This unit is equipped with a shut-off float valve. When the unit is used for wet pickup, the rising fluid lifts the float valve until it seals against the motor intake. When this happens, the sound of the motor changes to a higher pitch. Unplug the unit, empty the tank, and replace the cover.

### Dry Pickup

For optional dry pickup accessories, refer to "Optional Equipment" at the end of the Parts List.

## Maintenance

	<b>⚠ WARNING</b>
	<p>Electric shock hazard:</p> <ul style="list-style-type: none"> <li>Disconnect from power before servicing.</li> <li>Servicing should be performed by an authorized service representative.</li> </ul> <p>Failure to observe these warnings could result in severe injury or death.</p>

*Note: Keep filters clean. Efficiency of this vacuum is largely dependent on the cleanliness of the filters. A clogged filter can cause overheating and damage to the motor. Filters should be removed and cleaned periodically to ensure proper operation. After cleaning, allow filters to dry thoroughly to prevent deterioration.*

### FILTERS AND GASKETS

1. Unplug the unit
2. Remove the tank cover.
3. Unscrew three nuts from filter (located under the filter).
4. Clean the filters by spraying with water. Allow them to dry thoroughly.
5. Install the filters. Install the tank cover and secure with the catches.

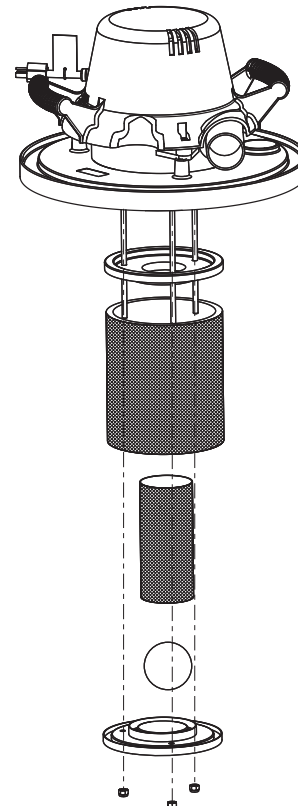



## Maintenance (cont'd)

### CLEANING AND STORAGE

Periodically wipe the outside of the tank with a damp cloth and mild detergent; do not use abrasives or solvents.

When not in use, store the 690 indoors in a cool, dry environment. Wrap the power cord loosely around the motor cover.

## Troubleshooting

<b>Problem</b>	<b>Probable Cause</b>	<b>Probable Remedy</b>
Unit does not run.	Faulty cord.	Replace cord.
	Faulty switch.	Replace switch.
	Faulty motor.	Replace motor.
Unit does not develop adequate vacuuming or blowing pressure.	Filters are dirty.	Clean the filters. Refer to the "Maintenance" section of this manual.
	Gaskets do not seal well.	Replace gaskets. Refer to the "Maintenance" section of this manual.
	Tank is full.	Empty the tank.
Piston does not travel through the conduit.	Wrong piston size.	Select the correct piston size.
	Conduit run is obstructed.	Clear the conduit run. Check for flattened bends.
	EMT couplings are loose.	Tighten the couplings.

**Illustration**

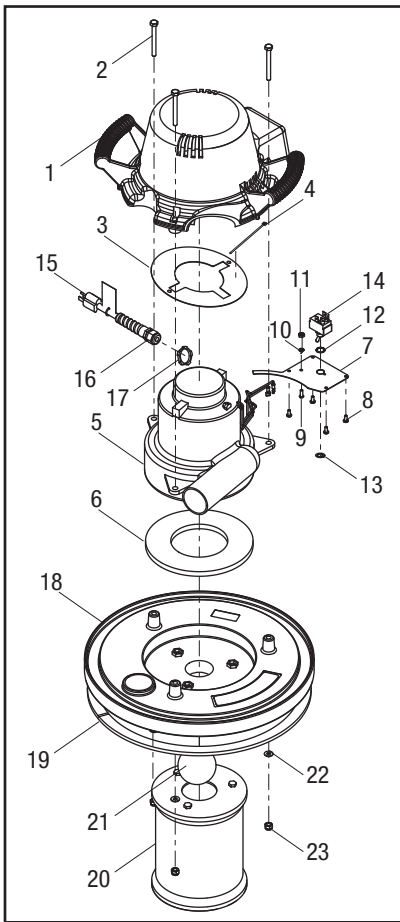

**690-RM  
Replacement  
Motor Kit  
(includes 1–23)**

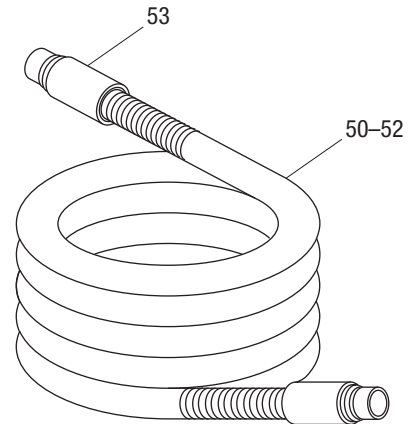

**690-RT  
Replacement  
Tank Kit  
(includes 30–48)**

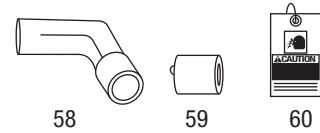
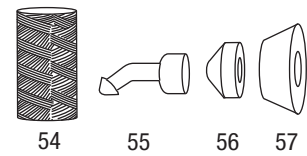
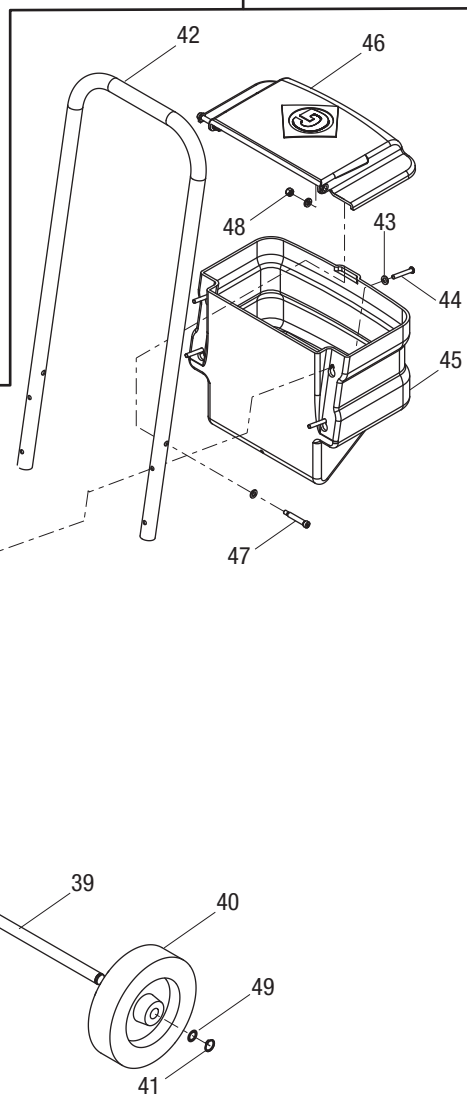

**OPTIONAL ACCESSORIES**

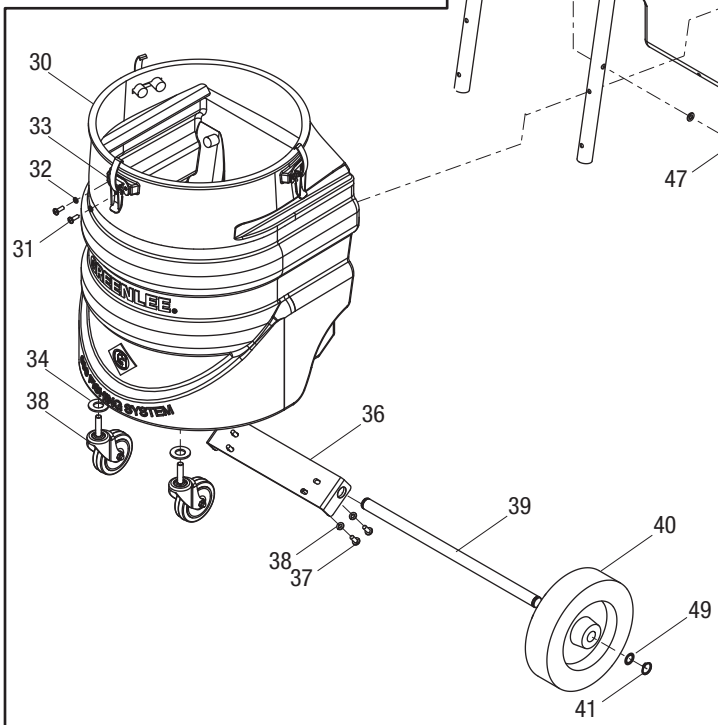
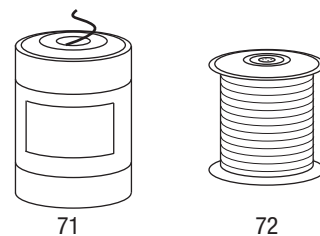
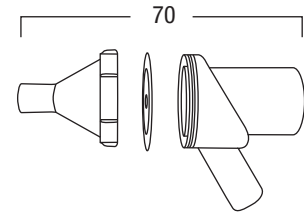

## Parts List

Key	Part No.	Description	Qty	Key	Part No.	Description	Qty
	<b>690-RM</b>	<b>Replacement motor kit— fits previous 690 model (includes 1–23)</b>		40		Wheel, 8 x 2.5 3/4 rlr brg .....	2
1		Cover, motor .....	1	41		Ring, retaining .750 Truarc #5100 ex .....	2
2		Bolt, 1/4-20 x 2.50 .....	3	42		Handle.....	1
3		Baffle, air .....	1	43		Washer, flat .32 x .57 x .06 cad pl.....	10
4		Tie, cable .....	1	44		Screw, 1/4-20 x 1.75 btn hd cap .....	4
5		Motor, electric 115 V.....	1	45		Box unit, storage.....	1
6		Gasket, blower.....	1	46		Lid, storage.....	1
7		Plate, switch .....	1	47		Screw, 5/16 x 1.5 shoulder .....	2
8		Screw, slftpg, #8-18 x .375 Phil pan hd.....	4	48		Nut, lock-hex, 1/4-20.....	2
9		Screw, machine #8-32 x .500 rd hd .....	1	49		Washer, Flat, .81 x 1.5 x .14.....	3
10		Washer, lock, .172 x .332 x .020 int T .....	2	50	RH10	Hose, vacuum, 10' w/cuffs .....	1
11		Nut, hex, #8-32 .....	2	51	RH15	Hose, vacuum, 15' w/cuffs .....	1
12		Washer, lock, .593 x .472 int.....	1	52	RH25	Hose, vacuum, 25' w/cuffs .....	1
13		Ring, locking .....	1	53		Cuff .....	2
14		Switch, toggle.....	1	54	595	Nylon line, 85 lb tensile-strength, length of 2150 ft.....	1
15		Cord, electric, 14 ga x 76" SJOW .....	1	55	50256467	Adapter cone, 1/2" through 1".....	1
16		Connector, strain relief.....	1	56	50256440	Adapter cone, 1-1/4 through 2-1/2" .....	1
17		Nut, 1/2 conduit lock .....	1	57	50256459	Adapter cone, 3" through 4" .....	1
18		Cover, tank.....	1	58	50233602	Fish line adapter, blowing .....	1
19		Gasket, tank cover.....	1	59	608	Piston for 1/2" conduit, foam type.....	1
20		Filter .....	1		609	Piston for 3/4" conduit, foam type.....	1
21		Ball, rubber, 2.50 dia. ....	1		610	Piston for 1" conduit, foam type.....	1
22		Washer, flat, .250 x .562 x .048 ZP #10 .....	3		611	Piston for 1-1/4" conduit, foam type ....	1
23		Nut, hex, 1/4-20 Nylok.....	3		612	Piston for 1-1/2" conduit, foam type ....	1
	<b>690-RT</b>	<b>Replacement tank kit— fits previous 690 model (includes 30–48)</b>			613	Piston for 2" conduit, foam type.....	1
30		Tank.....	1		614	Piston for 2-1/2" conduit, foam type ....	1
31		Screw, machine #12-24 x .625 rd hd .....	6		615	Piston for 3" conduit, foam type.....	1
32		Washer, lock, .225 x .377 x .056 spr zinc .....	6		616	Piston for 3-1/2" conduit, foam type ....	1
33		Catch, toggle, Nielsen #HC801ZE.....	3		617	Piston for 4" conduit, foam type.....	1
34		Washer, flat, .656 x 1.312 x .095 bk-ox.....	2		621	Piston for 2-1/2" EMT .....	1
35		Caster, swivel, 3.00 x .812 .....	2		646	Piston for 3-1/2" EMT .....	1
36		Bracket, axle.....	1		622	Piston for 3" EMT.....	1
37		Screw, 1/4-20 x .62 pan hd .....	4		623	Piston for 4" EMT.....	1
38		Washer, lock, .259 x .489 x .062 spr .....	4	60	50341189	Warning card.....	1
39		Axle, vacuum tank .750 x 16.03 .....	1	<b>Optional Accessories</b>			
				70	691	Mighty Mouser® blow gun .....	1
				71	430	Poly line bucket, 6500' .....	1
				72	435	Conduit measuring tape, 3/16" x 3000' .....	1

**Wiring Diagram**

