

INSTRUCTION MANUAL

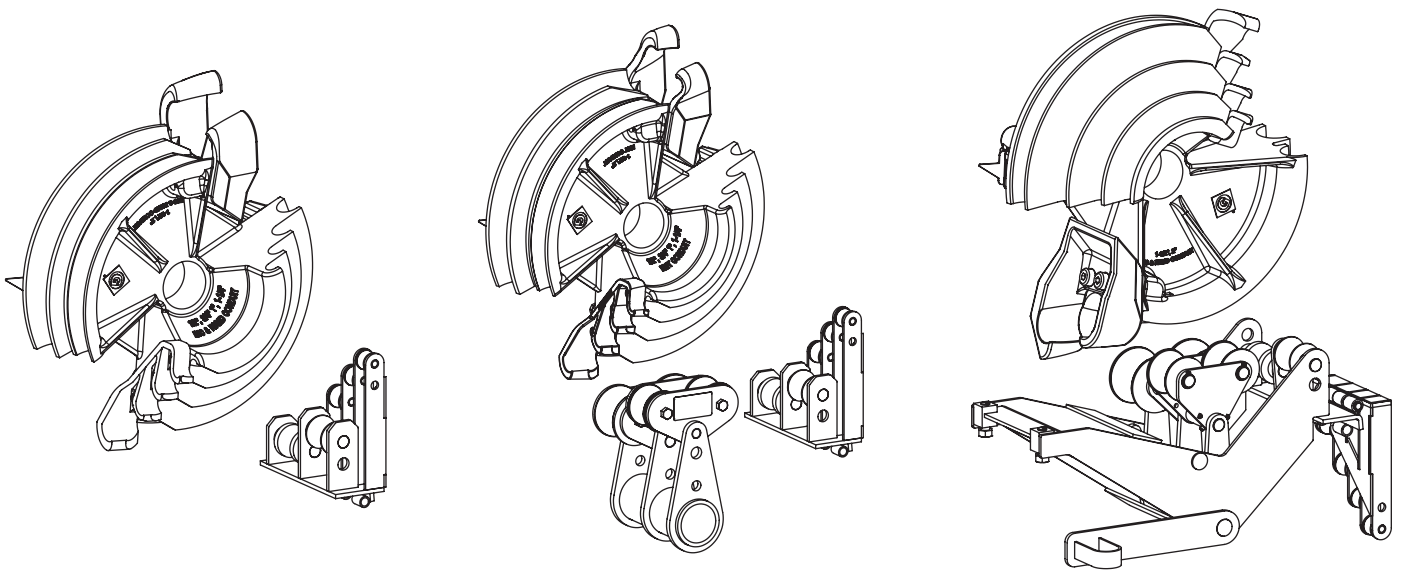

GREENLEE®

A Textron Company



Single-Shoe Groups for 555[®] Series Electric Benders



Read and understand all of the instructions and safety information in this manual before operating or servicing this tool.

Register this product at www.greenlee.com

Table of Contents

Description	2
Safety	2
Purpose of this Manual	2
Other Publications	2
Important Safety Information	3-4
Bending Attachment Groups.....	5-6
Setup	7-8
Operation.....	9
Illustrated Bending Glossary	10
Bending Instructions	11-12
Additional Bending Instructions	13-15
Additional Bending Tables.....	16-21
Illustrations and Parts Lists— Bending Shoes and Roller Supports	22-24

Description

The Greenlee single-shoe bending accessories are intended to bend conduit and pipe on Greenlee 555® Series Electric Benders. The single-shoe groups and bending capacities are listed below for each Greenlee electric bender model.

For 555C, 555CX, 555DX, and 555DX-22:

- 28008 Rigid Shoe Group — includes accessories for bending 1/2" to 2" rigid conduit, 1/2" to 2" schedule 40 pipe, and 1/2" to 1-1/4" IMC conduit
- 12586 PVC-Coated Rigid Shoe Group — includes accessories for bending 1/2" to 2" 40 MIL PVC-coated rigid conduit

For 555CX, 555DX, and 555DX-22 Only:

- 13934 EMT Shoe Group — includes accessories for bending 1/2" to 2" EMT conduit
- 13856 Squeeze Roller Assembly — accessory for bending 1-1/2" and 2" IMC conduit; requires 28008 rigid shoe group

For 555C Only:

- 23803 EMT Shoe Group — includes accessories for bending 1/2" to 2" EMT conduit
- 01323 Roller Support Assembly — accessory for bending 1/2" to 2" IMC conduit, 1/2" to 2" rigid conduit, and schedule 40 pipe; requires 28008 rigid shoe group

Safety

Safety is essential in the use and maintenance of Greenlee tools and equipment. This instruction manual and any markings on the tool provide information for avoiding hazards and unsafe practices related to the use of this tool. Observe all of the safety information provided.

Purpose of this Manual

This manual is intended to familiarize all personnel with the safe operation and setup procedures for the Greenlee 555® Series shoe groups.

Keep this manual available to all personnel.

Replacement manuals are available upon request at no charge at www.greenlee.com.

Other Publications

For additional information on safe operation and maintenance procedures, refer to the electric bender instruction manuals listed below:

- Publication 52055799 for 555CX and 555DX
- Publication 99936372 for 555C
- Publication 52060434 for 555DX-22
- Publication 52067623 for 555CX-22



Do not discard this product or throw away!

For recycling information, go to www.greenlee.com.

All specifications are nominal and may change as design improvements occur. Greenlee Textron Inc. shall not be liable for damages resulting from misapplication or misuse of its products.

555 is a registered trademark of Textron Innovations Inc.

Loctite is a registered trademark of Henkel Corp.

KEEP THIS MANUAL



IMPORTANT SAFETY INFORMATION



SAFETY ALERT SYMBOL

This symbol is used to call your attention to hazards or unsafe practices which could result in an injury or property damage. The signal word, defined below, indicates the severity of the hazard. The message after the signal word provides information for preventing or avoiding the hazard.

⚠ DANGER

Immediate hazards which, if not avoided, **WILL** result in severe injury or death.

⚠ WARNING

Hazards which, if not avoided, **COULD** result in severe injury or death.

⚠ CAUTION

Hazards or unsafe practices which, if not avoided, **MAY** result in injury or property damage.

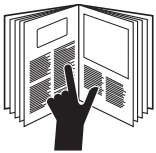

⚠ DANGER

Read and understand all of the instructions and safety information in this manual before operating or servicing this tool. Refer also to the bender instruction manuals, which are listed under "Other Publications."

Failure to observe this warning will result in severe injury or death.



⚠ DANGER

Do not use this tool in a hazardous environment. Hazards include flammable liquids, gases, or other materials. Using this tool in a hazardous environment can result in a fire or explosion.

Failure to observe this warning will result in severe injury or death.

⚠ WARNING

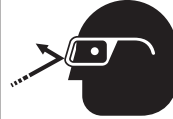

Always use safety glasses. Everyday glasses only have impact resistant lenses; they are **NOT** safety glasses. When using in dusty environment, use face or dust mask.

Failure to wear eye protection could result in serious eye injury from flying debris.

⚠ WARNING



Pinch points:

- Keep hands away from bending shoe, rollers, and conduit when bender is in use.
- Support conduit when unloading. Conduit can become loose and fall if not properly supported.

Failure to observe these warnings could result in severe injury or death.

⚠ WARNING

- Reduce the risk of unintentional starting. Make sure switch is in off position before plugging in.
- Never leave tool running unattended. Turn power off. Do not leave tool until it comes to a complete stop.
- Disconnect tools before servicing and when changing accessories such as shoes, rollers, and the like. Accidental start-up could result in serious injury.

Failure to observe these warnings could result in severe injury or death.

⚠ WARNING

- Never stand on tool. Serious injury could occur if the tool is tipped.
- Do not overreach. Keep proper footing and balance at all times.

Failure to observe these warnings could result in severe injury or death.



IMPORTANT SAFETY INFORMATION

⚠ CAUTION

- Conduit moves rapidly as it is bent. The path of the conduit must be clear of obstructions. Be sure clearance is adequate before starting the bend.
- Wear proper apparel. Do not wear loose clothing, gloves, neckties, rings, bracelets, or other jewelry which may get caught in moving parts. Nonslip footwear is recommended. Wear protective hair covering to contain long hair.
- Do not force rollers or alter tool. It will do the job better and safer at the rate for which it was designed.
- Use right tool. Do not force tool or attachment to do a job for which it was not designed.
- Use this tool for the manufacturer's intended purpose only. Use other than that which is instructed in this manual can result in injury or property damage.

Failure to observe these precautions may result in injury or property damage.

⚠ CAUTION

- Keep work area clean. Cluttered areas and benches invite accidents.
- Keep children away. All visitors should be kept safe distance from work area.
- Make workshop kid proof with padlocks, master switches, or by removing starter keys.

Failure to observe these precautions may result in injury or property damage.

⚠ CAUTION

- Inspect the bender before use. Replace worn, damaged, or missing parts with Greenlee replacement parts. A damaged or improperly assembled component could break and strike nearby personnel.
- Maintain tools with care. Keep tool clean for best and safest performance. Follow instructions for lubricating and changing accessories.
- Check damaged parts. Before further use of the tool, a guard or other part that is damaged should be carefully checked to determine that it will operate properly and perform its intended function. Check for alignment of moving parts, binding of moving parts, breakage of parts, mounting, and any other conditions that may affect its operation. A guard or other part that is damaged should be properly repaired or replaced.
- Use recommended accessories. Consult the instruction manual for recommended accessories. The use of improper accessories may cause risk of injury to persons.
- Some bender parts and accessories are heavy and may require more than one person to lift and assemble.

Failure to observe these precautions may result in injury or property damage.

Note: Keep all decals clean and legible, and replace when necessary.

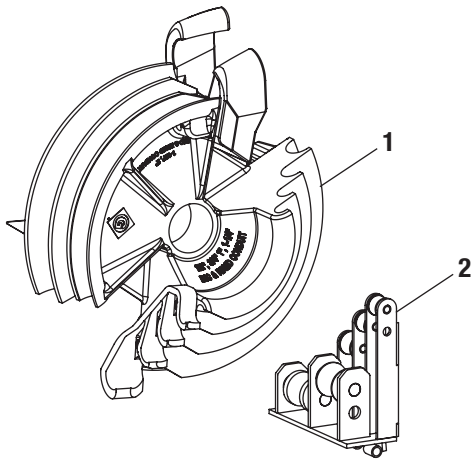
Bending Attachment Groups
RIGID

28008: 1/2" to 2" Rigid
1/2" to 1-1/4" IMC
1/2" to 2" Schedule 40 Pipe

Key	UPC No. 78-3310-	Description
1	02548	Bending shoe for 1/2" to 2"
2	02549	Roller support unit for 1/2" to 2"
	23818	Storage box

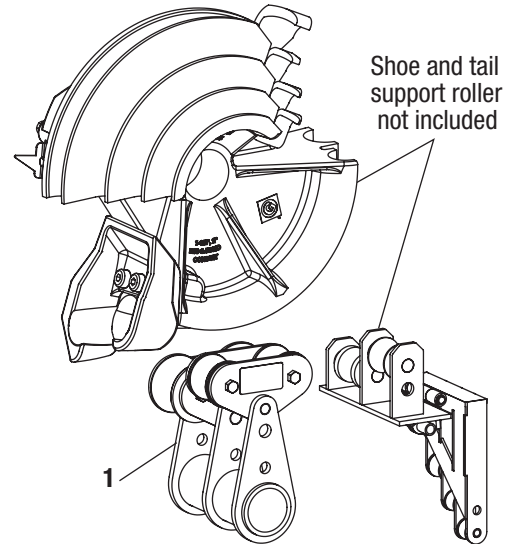
IMC (555CX, 555DX, and 555DX-22 only)

13856: 1-1/2" and 2" IMC

Key	UPC No. 78-3310-	Description
1	13856	Squeeze roller assembly

Note: 28008 rigid group is required to use the IMC squeeze roller.

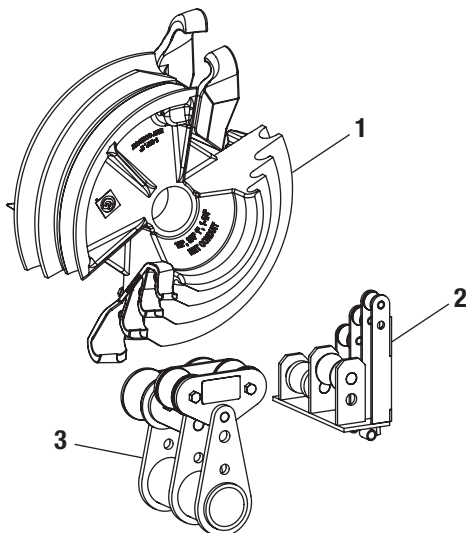
EMT (555CX, 555DX, and 555DX-22 only)

13934: 1/2" to 2" EMT

Key	UPC No. 78-3310-	Description
1	02543	Bending shoe for 1/2" to 2"
2	02567	Roller support unit for 1/2" to 2"
3	02552	Squeeze roller unit for 1-1/2" and 2"
	23818	Storage box

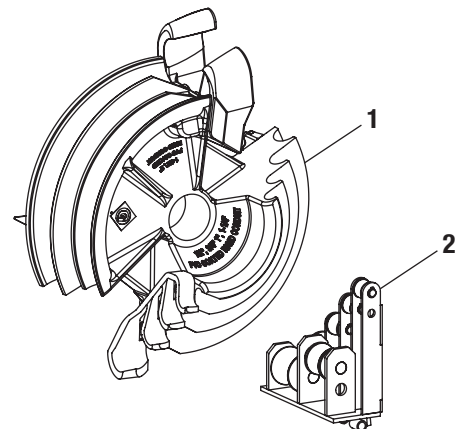
PVC-COATED RIGID

12586: 1/2" to 2" 40 MIL PVC-Coated Rigid

Key	UPC No. 78-3310-	Description
1	02553	Bending shoe for 1/2" to 2"
2	02554	Roller support unit for 1/2" to 2"
	23818	Storage box

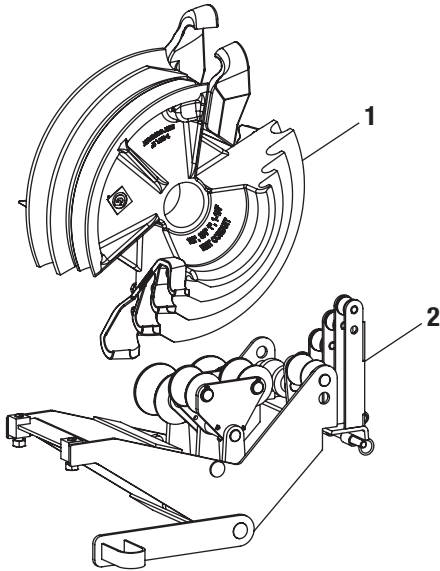
Bending Attachment Groups (cont'd)
EMT (555C only)

23803: 1/2" to 2" EMT

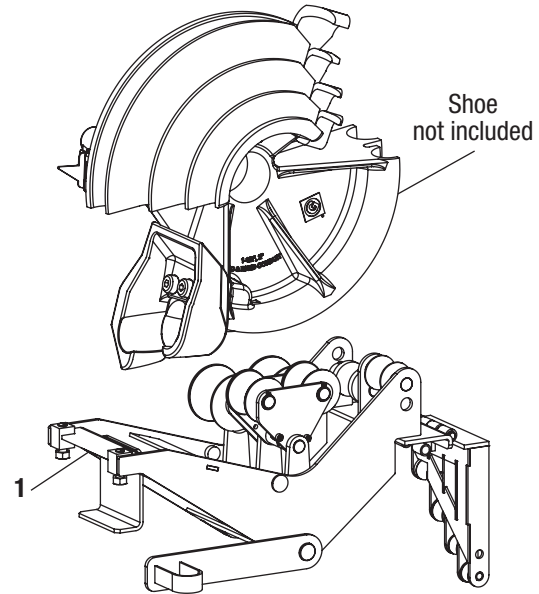
Key	UPC No. 78-3310-	Description
1	02543	Bending shoe for 1/2" to 2"
2	02544	Roller support unit for 1/2" to 2"
	23818	Storage box

IMC (555C only)

01323: 1/2" to 2" IMC

Key	UPC No. 78-3310-	Description
1	01323	Roller support assembly

Note: 02548 rigid/IMC shoe is required to use the 01323 roller support on the 555C bender.

Setup

	⚠ WARNING
	<p>Always use safety glasses. Everyday glasses only have impact resistant lenses; they are NOT safety glasses. When using in dusty environment, use face or dust mask.</p> <p>Failure to wear eye protection could result in serious eye injury from flying debris.</p>

⚠ WARNING
<p>Unplug the bender before changing accessories. Accidental start-up could result in serious injury.</p>

1. Slide the appropriate bending shoe onto the shaft of the main sprocket, as shown. Align the four drive studs on the back of the shoe with the four holes in the main sprocket.

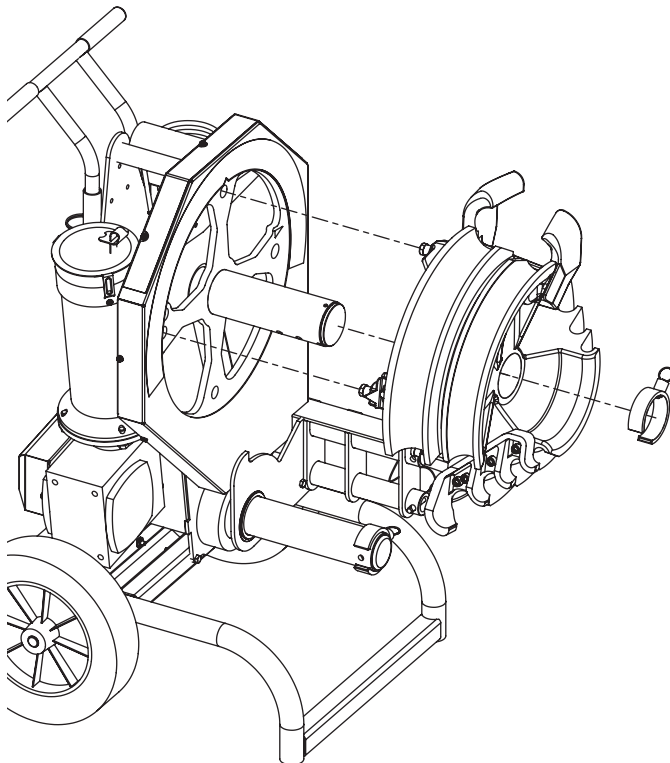
Installing a Bending Shoe

2. Mount the appropriate support unit onto the leg of the bender and install the hinge pin, as shown.

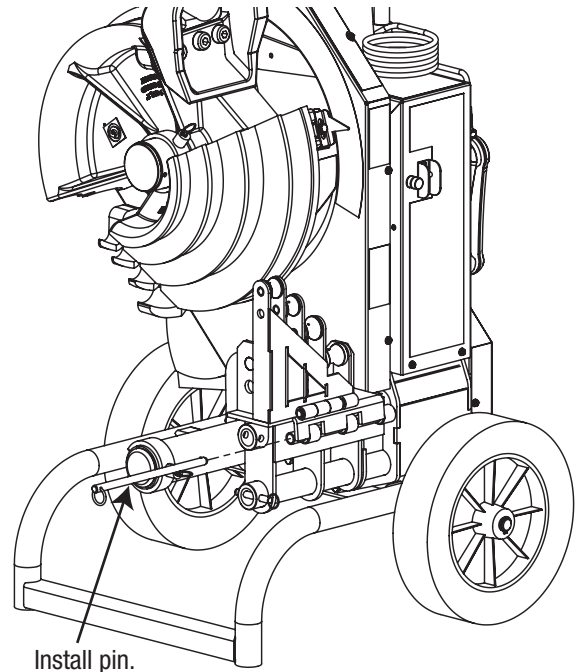

Install pin.

Roller Support Unit Installed

3. For 1-1/2" and 2" EMT or IMC, install the appropriate squeeze roller. Reinstall the roller engagement arm and roller retainer. Rotate the 1/2" to 1-1/4" rollers to the disengaged position as shown.

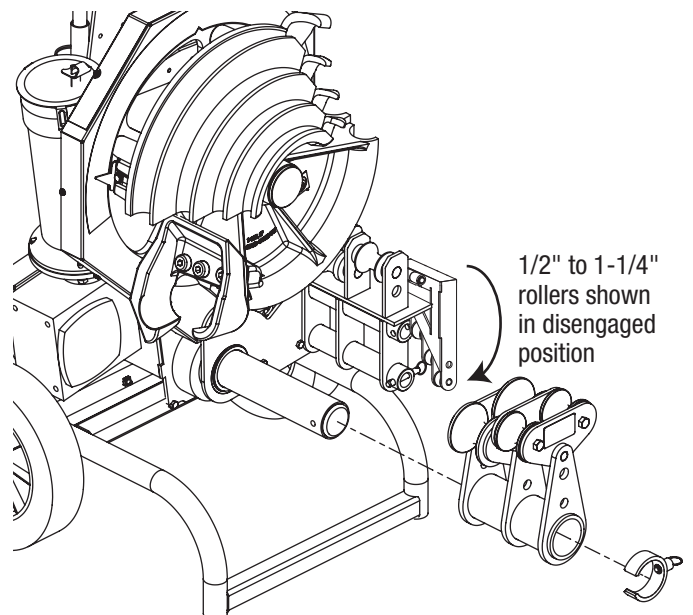

1/2" to 1-1/4" rollers shown in disengaged position

Setup (cont'd)

Note: The IMC single-shoe roller support has a trap plate that may require adjustment to properly fit around the leg of the bender. Verify that the trap plate is 3.06" (77.7 mm) below the leveling screws. If necessary, loosen the two hex head screws and adjust the distance. Retighten the screws.

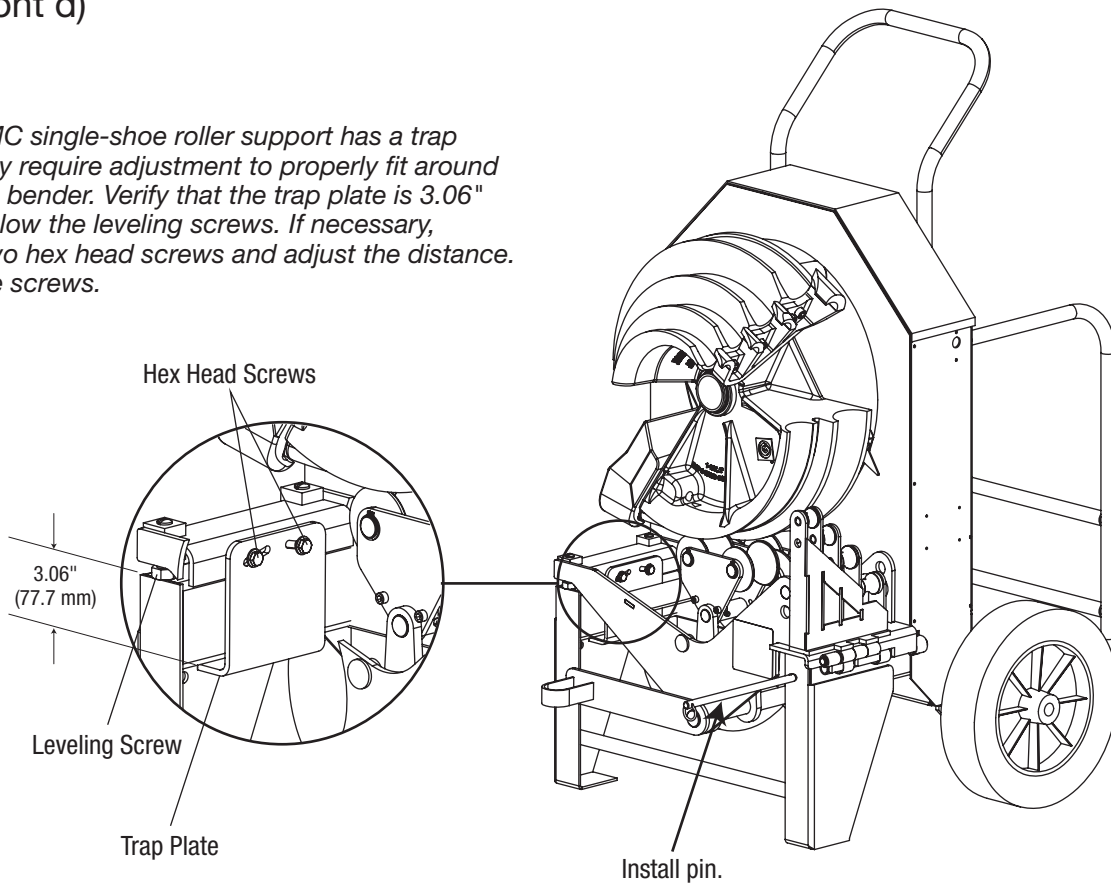

IMC Roller Support Unit Shown Installed on 555C

4. Add bending marks to the conduit for the desired bend. Refer to the "Bending Instructions" section of this manual or the decals on the bender.
5. Align the bending mark with the front edge of the hook on the bending shoe.
6. Refer to the instruction manual for the electric bender for additional safety and operating instructions.



Operation

	⚠ WARNING
	<p>Always use safety glasses. Everyday glasses only have impact resistant lenses; they are NOT safety glasses. When using in dusty environment, use face or dust mask.</p> <p>Failure to wear eye protection could result in serious eye injury from flying debris.</p>

	⚠ WARNING
	<p>Pinch points:</p> <p>Keep hands away from bending shoe, rollers, and conduit when bender is in use.</p> <p>Failure to observe this warning could result in severe injury or death.</p>

⚠ CAUTION
<p>Wear proper apparel. Do not wear loose clothing, gloves, neckties, rings, bracelets, or other jewelry which may get caught in moving parts. Nonslip footwear is recommended. Wear protective hair covering to contain long hair.</p> <p>Failure to observe this precaution may result in injury or property damage.</p>

ARROW ADJUSTMENT

The arrows on the single shoes can be adjusted to compensate for variations in conduit.

1. Load the conduit into the proper shoe groove.
2. Press BEND momentarily until the shoe rotates enough so that the conduit is snug in the hook.
3. Verify that the arrow position is aligned with 0° on the front protractor scale. If necessary, loosen the hex head screw and adjust the arrow to align with 0°. Retighten the hex head screw, as shown.

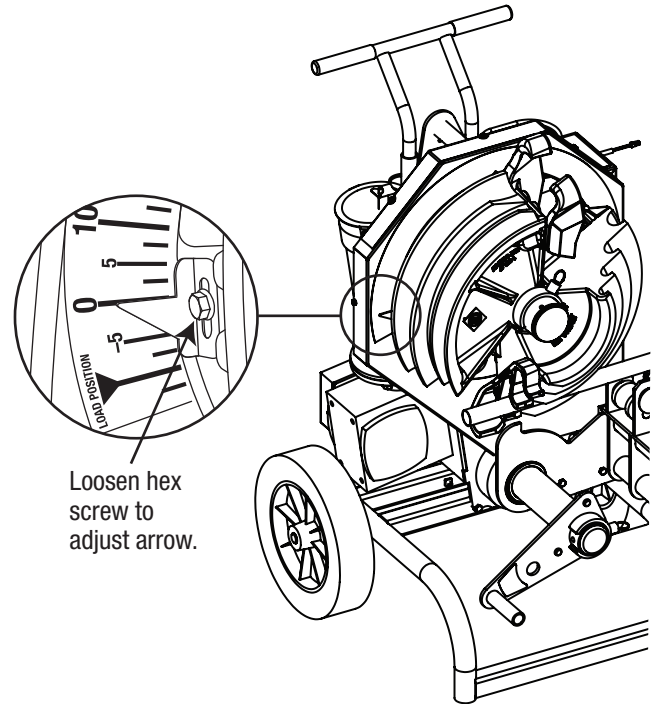

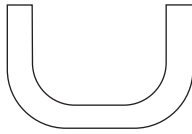
Illustrated Bending Glossary

back-to-back bend — any U-shaped bend formed by two parallel 90° bends with a straight section of conduit or pipe between the bends.

center-to-center distance — the distance between the successive bends that make up an offset or a three-bend saddle.

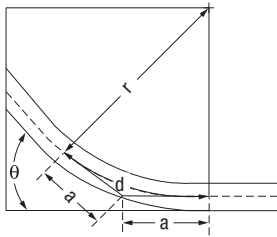

developed length — the actual length of pipe that will be bent; refer to distance “d” in the illustration at left.

gain — the difference between the straight-line distance ($a + a$) and the shorter radial distance, (d) where:

θ = angle of bend

r = the centerline bending radius of the bending shoe

kick — single bend of less than 90°

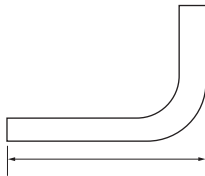

leg length — the distance from the end of a straight section of conduit or pipe to the bend; measured from the end to the outside edge of the conduit or pipe.

offset bend — two opposite bends with the same degree of bend; used to avoid an obstruction.

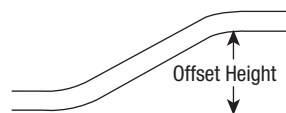

offset height — the distance between the two legs of an offset bend, measured perpendicular to the two legs; also called amount of offset and depth of offset.

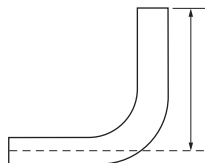

rise — the distance from the end of a straight section of conduit or pipe to the bend; measured from the end to the center line of the conduit or pipe. Also called stub or stub-up.

saddle — a three-bend or four-bend combination; used to avoid an obstruction.

shrink — the amount of conduit “lost” when laying out an offset bend working toward an obstruction.

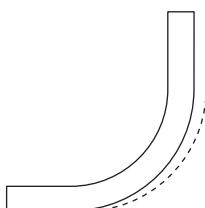

springback — the amount, measured in degrees, that a conduit or pipe tends to straighten after being bent.

Bending Instructions

90° STUBS

1. Measure the length of the required stub.
2. Refer to the Minimum Stub Length formula on the Deduct Table. The required stub must be equal to or longer than the Minimum Stub Length.
3. Measure and mark the stub length on the conduit. This is Mark 1. Subtract the Deduct from this mark and make a new mark. This is Mark 2.
4. Align Mark 2 with the front edge of the hook and bend the conduit.

*Note: When the operator presses **UNLOAD**, the conduit may spring back a few degrees. Compensate by over-bending as shown in the Scale Reading Tables.*

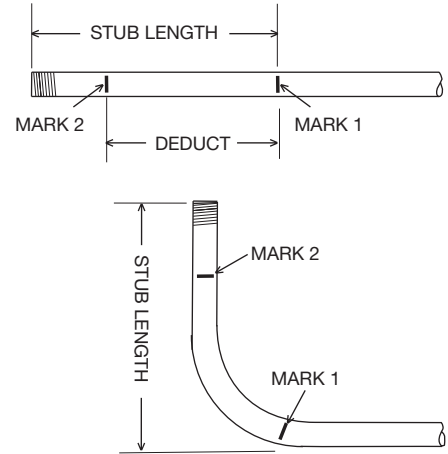

Deduct Table for EMT, IMC, and Rigid Shoe Groups

CONDUIT SIZE		1/2	3/4	1	1-1/4	1-1/2	2
DEDUCT	RIGID/IMC/ PVC-COATED RIGID	7-1/2	9	11	13-5/8	14-7/8	16-1/8
	EMT	7-1/2	9	11	13-5/8	14-7/8	16-3/8
MINIMUM STUB LENGTH = DEDUCT PLUS 2 INCHES							

Figures are approximate

Scale Reading Table

CONDUIT SIZE	RIGID					EMT					IMC				
	15°	30°	45°	60°	90°	15°	30°	45°	60°	90°	15°	30°	45°	60°	90°
1/2	17	33	49	64	96	16	32	48	63	95	20	36	51	67	98
3/4	17	33	48	64	95	17	33	48	64	95	19	35	50	66	97
1	17	32	48	63	94	17	32	48	63	94	19	35	50	66	97
1-1/4	17	32	48	63	94	17	32	48	63	94	19	35	50	66	97
1-1/2	17	32	48	63	94	19	35	50	66	97	17	33	49	64	96
2	17	32	48	63	94	19	34	50	65	96	19	34	50	65	96

Figures are approximate

Note: Due to varying conduit material properties, 1-1/2" or 2" aluminum rigid may require IMC squeeze rollers for bending. If flattening occurs, reduce the squeeze setting two positions and use IMC bending procedures.

**Scale Reading Table—
PVC-Coated Rigid**

CONDUIT SIZE	PVC-COATED RIGID				
	15°	30°	45°	60°	90°
1/2	16	31	47	62	93
3/4	15	31	46	62	93
1	16	32	47	63	94
1-1/4	15	30	46	61	92
1-1/2	18	33	49	64	95
2	19	34	50	65	96

Figures are approximate

Bending Instructions (cont'd)

Offsets

1. Measure the height and length of the obstruction. Select the angle to be used.
2. Refer to the Offset Table. The height of the obstruction must be equal to or greater than the minimum offset.
3. Refer to the X Table to find the X dimension. Refer to the Offset Table to find the center-to-center distance.

Note: If the center-to-center distance is not shown, calculate it by using the multipliers shown in the Offset Table.

4. Mark the conduit as shown.
5. Insert the conduit into the bender. Align Mark 1 with the front edge of the hook and bend the conduit.
6. Align Mark 2 with the front edge of the hook. Without removing the conduit from the bender, rotate the conduit 180°. Make the second bend.

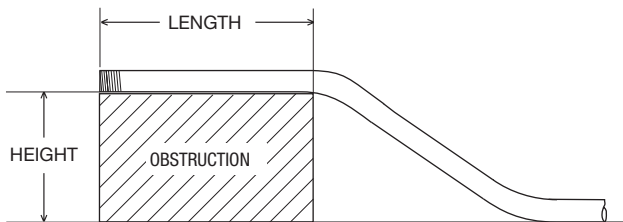
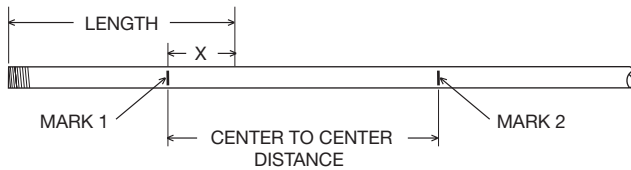

Offset Table

OFFSET ▶		2	4	6	8	10
15°	Max. Conduit Size	3/4	1-1/2	2		
	Center-to-Center	7-3/4	15-7/16	23-3/16	30-15/16	38-5/8
30°	Max. Conduit Size		3/4	1	1-1/2	2
	Center-to-Center		8	12	16	20
45°	Max. Conduit Size			1/2	1	1-1/4
	Center-to-Center			8-1/2	11-5/16	14-1/8

OFFSET ▶		12	14	16	18	20	22
15°	Max. Conduit Size	2					
	Center-to-Center	46-3/8	54-1/16	61-13/16	69-9/16	77-1/4	85
30°	Max. Conduit Size	2					
	Center-to-Center	24	28	32	36	40	44
45°	Max. Conduit Size	1-1/2	2				
	Center-to-Center	16-15/16	19-13/16	22-5/8	25-7/16	28-1/4	31-1/8

CENTER-TO-CENTER DISTANCE = OFFSET HEIGHT x MULTIPLIER					
OFFSET ANGLE	10°	15°	22-1/2°	30°	45°
MULTIPLIER	5.8	3.9	2.6	2.0	1.4

Figures are approximate

X Table for EMT, IMC, Rigid, and PVC-Coated Rigid Shoe Groups

CONDUIT SIZE	1/2	3/4	1	1-1/4	1-1/2	2
"X"	3-1/16	3-1/16	3-3/16	4	4-1/4	4-1/2

Figures are approximate

Centerline Bending Radii for EMT, IMC, and Rigid Shoe Groups

SHOE SIZE	EMT		IMC/RIGID/ PVC-COATED RIGID	
	in	mm	in	mm
1/2	4-5/16	109.5	4-1/4	108
3/4	5-1/2	139.7	5-7/16	138.1
1	7	177.8	6-15/16	176.2
1-1/4	8-13/16	223.8	8-3/4	222.3
1-1/2	8-3/8	212.7	8-1/4	209.6
2	9-1/4	235.0	9	228.6

Additional Bending Instructions

The following drawings and bending tables are intended to provide the information necessary to accomplish the most common types of bends. The bending tables contain conduit marking information.

STUBS

1. Select the size and type of conduit. Determine the height of stub and the angle to be used.
2. Find the table that corresponds to the size and type of conduit selected in Step 1.
3. Under the column labeled ANGLE, find the appropriate angle.
4. Find the row labeled Y. In the row at the top of the page, find the height (H) of the stub. The number shown at the intersection of row Y and column H is the distance Y. Place the bending mark Y inches from the end of the conduit.
5. Bend the conduit.

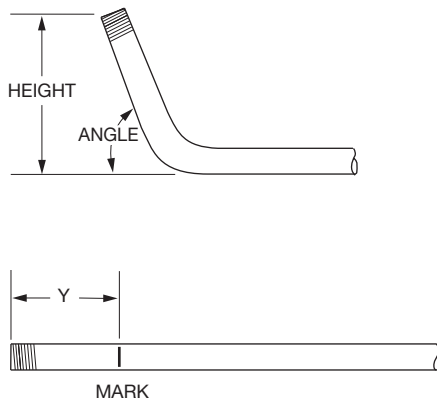

OFFSETS

An offset is used to route the conduit around an obstruction. To make an offset, two equal bends are required. The distance between the two bends is the center-to-center distance.

When working past an obstruction, it is necessary to determine the location of the first bend. The center-to-center distance is then used to determine the location of the second bend. When working toward an obstruction, it is necessary to determine the location of the second bend. The center-to-center distance is then used to determine the location of the first bend.

Working Past an Obstruction

1. Select the size and type of conduit. Measure the height of the obstruction and the distance labeled LENGTH. Determine the angle to be used.
2. Find the table that corresponds to the size and type of conduit selected in Step 1.
3. To the right of the size and type of conduit, find the dimension labeled X. Subtract X from LENGTH. Place the first bending mark this distance from the end of the conduit.
4. Under the column labeled ANGLE, find the appropriate angle. Find the row labeled L1. In the row at the top of the page, find the height (H) of the offset. The number shown at the intersection of row L1 and column H is L1. Place the second bending mark L1 inches from the first bending mark.
5. Bend the conduit.

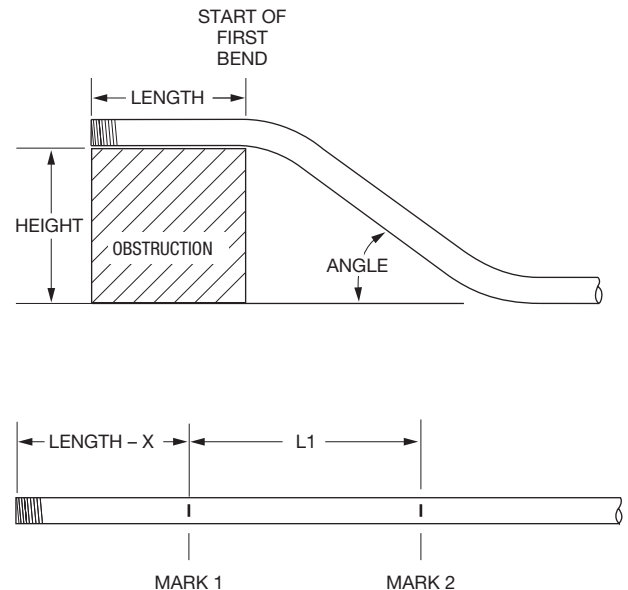

Additional Bending Instructions (cont'd)

Working Toward an Obstruction

1. Select the size and type of conduit. Measure the height of the obstruction and the distance labeled **LENGTH TO END OF SECOND BEND**. Determine the angle to be used.
2. Find the table that corresponds to the size and type of conduit selected in Step 1.
3. Under the column labeled **ANGLE**, find the appropriate angle. Find the row labeled **Z**. In the row at the top of the page, find the height (**H**) of the offset. The number shown at the intersection of the **Z** row and the **H** column is **Z**. Subtract **Z** from **LENGTH TO THE END OF SECOND BEND**. Place the first bending mark this distance from the end of the conduit.
4. In the same column, find the row labeled **L1**. Place the second bending mark **L1** inches from the first bending mark.
5. Bend the conduit.

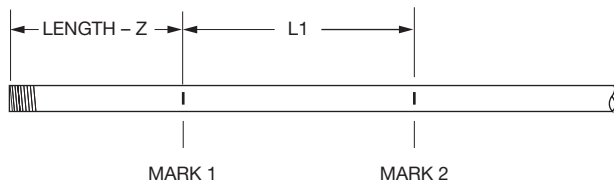
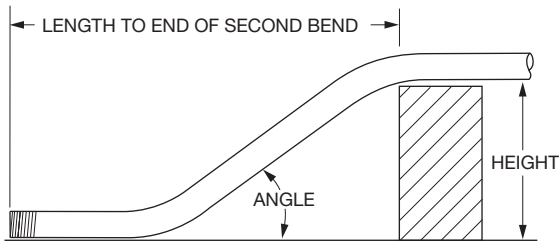

THREE-BEND SADDLE

1. Select the size and type of conduit. Measure the height of the obstruction and the distance from the end of the conduit to the center (**LENGTH TO CENTER**) of the bend. Determine the angle to be used.
2. Find the table that corresponds to the size and type of conduit selected in Step 1.
3. Under the column labeled **ANGLE**, find the appropriate angle. Find the row labeled **Z**. In the row at the top of the page, find the height (**H**) of the offset. The number shown at the intersection of the **Z** row and the appropriate **H** column is **Z**. Subtract **Z** from the **LENGTH TO CENTER**. Place the first bending mark this distance from the end of the conduit.
4. In the same column, find the row labeled **L1**. Place the second bending mark **L1** inches from the first bending mark.
5. In the same column, find the row labeled **L2**. Place the third bending mark **L2** inches from the second bending mark.
6. Bend the conduit.

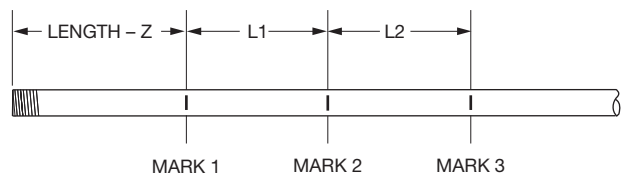
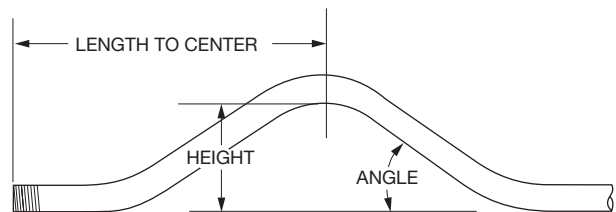

Additional Bending Instructions (cont'd)

FOUR-BEND SADDLE

1. Select the size and type of conduit. Measure the height of the obstruction, the distance labeled LENGTH, and the distance labeled STRAIGHT SECTION. Determine the angle to be used.
2. Find the table that corresponds to the size and type of conduit selected in Step 1.
3. Under the column labeled ANGLE, find the appropriate angle. Find the row labeled Z. In the row at the top of the page, find the height (H) of the offset. The number shown at the intersection of the Z row and the appropriate H column is Z. Subtract Z from the LENGTH. Place the first bending mark this distance from the end of the conduit.
4. In the same column, find the row labeled L1. Place the second bending mark L1 inches from the first bending mark.
5. In the same column, find the row labeled L2. Add L2 to the STRAIGHT SECTION. Place the third bending mark this distance from the first bending mark.
6. Make the final bending mark L1 inches from the third bending mark.
7. Bend the conduit.

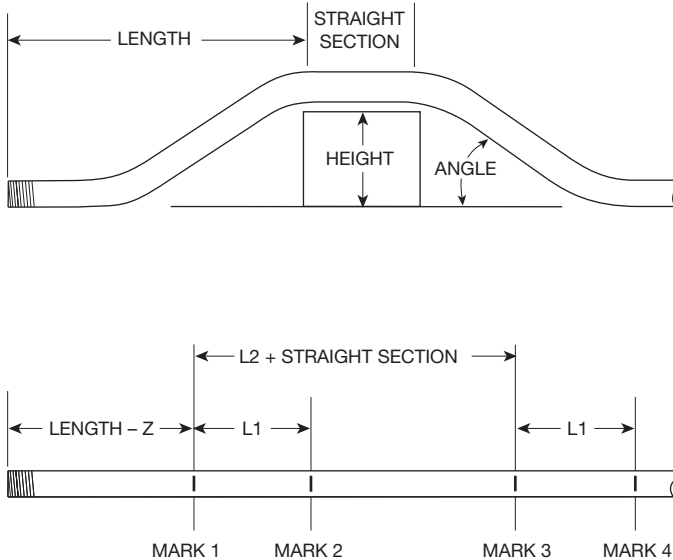

U-BENDS

1. Select the size and type of conduit. Determine the LENGTH and the HEIGHT.
2. Find the table that corresponds to the size and type of conduit selected in Step 1.
3. Under the column labeled ANGLE, find 90°.
4. Find the row labeled Y. In the row at the top of the page, find the height (H) that corresponds to the LENGTH. The number shown at the intersection of the Y row and the appropriate H column is the distance Y. Place the bending mark Y inches from the end of the conduit.
5. Find the row labeled L1, and go to the right to find the height (H) that corresponds to the HEIGHT.
6. The number shown at the intersection of the L1 row and the appropriate H column is L1. Place the second bending mark L1 inches from the first mark.
7. Bend the conduit.

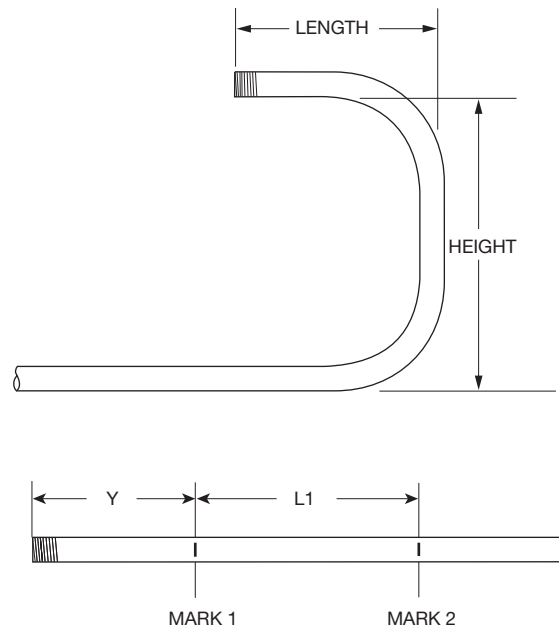

Additional Bending Tables

	DIM	ANGLE	2"	4"	6"	8"	10"	12"	15"	18"	24"	36"
1/2" EMT												
	Y	15	3.74	11.47	19.20	26.92	34.65	42.38	53.97	65.56	88.74	135.11
	L1	15	7.72	15.45	23.18	30.90	38.63	46.36	57.95	69.54	92.72	139.09
	L2	15	8.94	16.66	24.39	32.12	39.84	47.57	59.16	70.75	93.94	140.30
	Z	15	10.70	18.16	25.62	33.09	40.55	48.02	59.21	70.41	92.80	137.59
MINIMUM H = 0.84												
	Y	22.5	1.37	6.60	11.82	17.05	22.28	27.50	35.34	43.18	58.86	90.22
	L1	22.5	5.20	10.43	15.65	20.88	26.11	31.33	39.17	47.01	62.69	94.05
	L2	22.5	7.02	12.25	17.48	22.70	27.93	33.16	41.00	48.83	64.51	95.87
	Z	22.5	8.68	13.51	18.34	23.17	28.00	32.83	40.07	47.31	61.80	90.77
MINIMUM H = 1.48												
	Y	30	0.04	4.04	8.04	12.04	16.04	20.04	26.04	32.04	44.04	68.04
	L1	30		7.94	11.94	15.94	19.94	23.94	29.94	35.94	47.94	71.94
	L2	30		10.37	14.37	18.37	22.37	26.37	32.37	38.37	50.37	74.37
	Z	30		11.42	14.89	18.35	21.82	25.28	30.48	35.67	46.07	66.85
MINIMUM H = 2.25												
	Y	45		1.23	4.05	6.88	9.71	12.54	16.78	21.02	29.51	46.48
	L1	45			8.29	11.11	13.94	16.77	21.01	25.26	33.74	50.71
	L2	45			11.93	14.76	17.59	20.42	24.66	28.90	37.39	54.36
	Z	45			11.85	13.85	15.85	17.85	20.85	23.85	29.85	41.85
MINIMUM H = 4.14												
	Y	60			1.83	4.14	6.45	8.76	12.22	15.69	22.62	36.47
	L1	60				8.74	11.05	13.36	16.82	20.29	27.21	41.07
	L2	60				13.60	15.91	18.22	21.68	25.14	32.07	45.93
	Z	60				11.99	13.14	14.30	16.03	17.76	21.22	28.15
MINIMUM H = 6.38												
	Y	90				1.00	3.00	5.00	8.00	11.00	17.00	29.00
	L1	90						10.01	13.01	16.01	22.01	34.01
	L2	90						17.30	20.30	23.30	29.30	41.30
	Z	90						11.29	11.29	11.29	11.29	11.29
MINIMUM H = 11.29												
3/4" EMT												
	Y	15	2.35	10.07	17.80	25.53	33.26	40.98	52.58	64.17	87.35	133.71
	L1	15	7.72	15.45	23.17	30.90	38.63	46.36	57.95	69.54	92.72	139.08
	L2	15	9.17	16.90	24.62	32.35	40.08	47.81	59.40	70.99	94.17	140.54
	Z	15	11.79	19.26	26.72	34.19	41.65	49.11	60.31	71.51	93.90	138.68
MINIMUM H = 1.12												
	Y	22.5	0.05	5.28	10.50	15.73	20.95	26.18	34.02	41.86	57.54	88.90
	L1	22.5	5.20	10.42	15.65	20.88	26.10	31.33	39.17	47.01	62.69	94.04
	L2	22.5	7.37	12.60	17.83	23.05	28.28	33.50	41.34	49.18	64.86	96.22
	Z	22.5	9.90	14.73	19.56	24.39	29.22	34.04	41.29	48.53	63.02	91.99
MINIMUM H = 1.94												
	Y	30		2.72	6.72	10.72	14.72	18.72	24.72	30.72	42.72	66.72
	L1	30		7.93	11.93	15.93	19.93	23.93	29.93	35.93	47.93	71.93
	L2	30		10.83	14.83	18.83	22.83	26.83	32.83	38.83	50.83	74.83
	Z	30		12.77	16.23	19.70	23.16	26.62	31.82	37.02	47.41	68.19
MINIMUM H = 2.92												
	Y	45			2.67	5.50	8.33	11.15	15.40	19.64	28.12	45.09
	L1	45			8.25	11.08	13.90	16.73	20.97	25.22	33.70	50.67
	L2	45			12.60	15.43	18.25	21.08	25.33	29.57	38.05	55.02
	Z	45			13.46	15.46	17.46	19.46	22.46	25.46	31.46	43.46
MINIMUM H = 5.27												
	Y	60			0.33	2.64	4.95	7.26	10.72	14.18	21.11	34.97
	L1	60					10.95	13.26	16.72	20.19	27.12	40.97
	L2	60					16.75	19.06	22.53	25.99	32.92	46.78
	Z	60					15.04	16.20	17.93	19.66	23.12	30.05
MINIMUM H = 8.03												
	Y	90					1.13	3.13	6.13	9.13	15.13	27.13
	L1	90							12.62	15.62	21.62	33.62
	L2	90							21.32	24.32	30.32	42.32
	Z	90							13.95	13.95	13.95	13.95
MINIMUM H = 13.95*												

*MINIMUM H = 16.25 on U-bends

Additional Bending Tables (cont'd)

	DIM	ANGLE	2"	4"	6"	8"	10"	12"	15"	18"	24"	36"
1" EMT												
	Y	15	1.35	9.07	16.80	24.53	32.26	39.98	51.57	63.16	86.35	132.71
	L1	15	7.72	15.44	23.17	30.90	38.63	46.35	57.95	69.54	92.72	139.08
	L2	15	9.54	17.26	24.99	32.72	40.45	48.17	59.76	71.36	94.54	140.90
	Z	15	12.51	19.98	27.44	34.91	42.37	49.83	61.03	72.23	94.62	139.40
MINIMUM H = 1.31												
	Y	22.5		4.33	9.56	14.78	20.01	25.24	33.07	40.91	56.59	87.95
	L1	22.5		10.42	15.64	20.87	26.10	31.32	39.16	47.00	62.68	94.04
	L2	22.5		13.15	18.37	23.60	28.82	34.05	41.89	49.73	65.41	96.77
	Z	22.5		15.64	20.47	25.30	30.13	34.96	42.20	49.44	63.93	92.90
MINIMUM H = 2.29												
	Y	30		1.75	5.75	9.75	13.75	17.75	23.75	29.75	41.75	65.75
	L	30		7.91	11.91	15.91	19.91	23.91	29.91	35.91	47.91	71.91
	L2	30		11.55	15.55	19.55	23.55	27.55	33.55	39.55	51.55	75.55
	Z	30		13.87	17.34	20.80	24.27	27.73	32.92	28.12	48.51	69.30
MINIMUM H = 3.47												
	Y	45			1.56	4.39	7.22	10.05	14.29	18.53	27.02	43.99
	L1	45				11.01	13.84	16.67	20.91	25.16	33.64	50.61
	L2	45				16.47	19.30	22.13	26.37	30.62	39.10	56.07
	Z	45				16.98	18.98	20.98	23.98	26.98	32.98	44.98
MINIMUM H = 6.35												
	Y	60				1.33	3.64	5.95	9.42	12.88	19.81	33.67
	L1	60					10.80	13.11	16.57	20.04	26.97	40.82
	L2	60					18.08	20.39	23.85	27.32	34.24	48.10
	Z	60					17.02	18.17	19.91	21.64	25.10	32.03
MINIMUM H = 9.74												
	Y	90						1.25	4.25	7.25	13.25	25.25
	L1	90								15.02	21.02	33.02
	L2	90								25.93	31.93	43.93
	Z	90								17.12	17.12	17.12
MINIMUM H = 17.12												
1-1/4" EMT												
	Y	15	0.26	7.99	15.72	23.45	31.17	38.90	50.49	62.08	85.27	131.63
	L1	15	7.71	15.44	23.17	30.90	38.62	46.35	57.94	69.53	92.72	139.08
	L2	15	10.07	17.80	25.52	33.25	40.98	48.71	60.30	71.89	95.07	141.44
	Z	15	13.20	20.66	28.12	35.59	43.05	50.52	61.71	72.91	95.30	140.09
MINIMUM H = 1.48												
	Y	22.5		3.33	8.55	13.78	19.01	24.23	32.07	39.91	55.59	86.95
	L1	22.5		10.41	15.63	20.86	26.09	31.31	39.15	46.99	62.67	94.03
	L2	22.5		13.94	19.17	24.40	29.62	34.85	42.69	50.53	66.21	97.56
	Z	22.5		16.60	21.43	26.26	31.09	35.91	43.16	50.40	64.89	93.86
MINIMUM H = 2.66												
	Y	30		0.72	4.72	8.72	12.72	16.72	22.72	28.72	40.72	64.72
	L1	30			11.89	15.89	19.89	23.89	29.89	35.89	47.89	71.89
	L2	30			16.61	20.61	24.61	28.61	34.61	40.61	52.61	76.61
	Z	30			18.58	22.04	25.51	28.97	34.17	39.37	49.76	70.54
MINIMUM H = 4.09												
	Y	45			0.33	3.15	5.98	8.81	13.05	17.30	25.78	42.75
	L1	45				10.93	13.75	16.58	20.83	25.07	33.55	50.52
	L2	45				18.00	20.83	23.66	27.90	32.14	40.63	57.60
	Z	45				18.82	20.82	22.82	25.82	28.82	34.82	46.82
MINIMUM H = 7.65												
	Y	60					2.11	4.42	7.89	11.35	18.28	32.14
	L1	60						12.89	16.35	19.82	26.74	40.60
	L2	60						22.32	25.79	29.25	36.18	50.04
	Z	60						20.69	22.42	24.16	27.62	34.55
MINIMUM H = 11.92												
	Y	90							1.88	4.88	10.88	22.88
	L1	90									20.13	32.13
	L2	90									34.29	46.29
	Z	90									21.38	21.38
MINIMUM H = 21.38												

Additional Bending Tables (cont'd)

	DIM	ANGLE	2"	4"	6"	8"	10"	12"	15"	18"	24"	36"
1-1/2" EMT												
	Y	15		6.26	13.99	21.72	29.44	37.17	48.76	60.35	83.53	129.90
	L1	15	7.71	15.44	23.17	30.90	38.62	46.35	57.94	69.53	92.72	139.08
	L2	15	9.95	17.68	25.40	33.13	40.86	48.58	60.18	71.77	94.95	141.31
	Z	15	14.42	21.88	29.35	36.81	44.28	51.74	62.94	74.13	96.53	141.31
MINIMUM H = 1.81												
	Y	22.5		1.77	7.00	12.22	17.45	22.68	30.52	38.36	54.03	85.39
	L1	22.5		10.41	15.64	20.86	26.09	31.31	39.15	46.99	62.67	94.03
	L2	22.5		13.76	18.98	24.21	29.44	34.66	42.50	50.34	66.02	97.38
	Z	22.5		17.76	22.59	27.42	32.25	37.07	44.32	51.56	66.04	95.02
MINIMUM H = 3.11												
	Y	30			3.26	7.26	11.26	15.26	21.26	27.26	39.26	63.26
	L1	30			11.90	15.90	19.90	23.90	29.90	35.90	47.90	71.90
	L2	30			16.36	20.36	24.36	28.36	34.36	40.36	52.36	76.36
	Z	30			19.67	23.14	26.60	30.07	35.26	40.46	50.85	71.64
MINIMUM H = 4.64												
	Y	45				1.84	4.67	7.50	11.74	15.98	24.47	41.44
	L1	45					13.78	16.60	20.85	25.09	33.57	50.54
	L2	45					20.47	23.30	27.55	31.79	40.27	57.24
	Z	45					21.78	23.78	26.78	29.78	35.78	47.78
MINIMUM H = 8.33												
	Y	60					0.91	3.22	6.68	10.15	17.07	30.93
	L1	60							16.40	19.87	26.80	40.65
	L2	60							25.34	28.80	35.73	49.58
	Z	60							23.22	24.95	28.42	35.34
MINIMUM H = 12.61												
	Y	90							0.89	3.89	9.89	21.89
	L1	90									20.34	32.34
	L2	90									33.74	45.74
	Z	90									21.77	21.77
MINIMUM H = 21.77												
2" EMT												
	Y	15		5.15	12.87	20.60	28.33	36.05	47.65	59.24	82.42	128.78
	L1	15	7.71	15.44	23.17	30.90	38.62	46.35	57.94	69.53	92.71	139.08
	L2	15	10.19	17.92	25.64	33.37	41.10	48.83	60.42	72.01	95.19	141.56
	Z	15	14.77	22.24	29.70	37.17	44.63	52.10	63.29	74.49	96.88	141.66
MINIMUM H = 1.89												
	Y	22.5		0.88	6.11	11.33	16.56	21.79	29.62	37.46	53.14	84.50
	L1	22.5		10.40	15.63	20.86	26.08	31.31	39.15	46.99	62.67	94.02
	L2	22.5		14.12	19.35	24.57	29.80	35.02	42.86	50.70	66.38	97.74
	Z	22.5		18.24	23.07	27.90	32.73	37.55	44.80	52.04	66.52	95.50
MINIMUM H = 3.28												
	Y	30			2.45	6.45	10.45	14.45	20.45	26.45	38.45	62.45
	L1	30			11.88	15.88	19.88	23.88	29.88	35.88	47.88	71.88
	L2	30			16.84	20.84	24.84	28.84	34.84	40.84	52.84	76.84
	Z	30			20.28	23.75	27.21	30.67	35.87	41.07	51.46	72.24
MINIMUM H = 4.94												
	Y	45				1.02	3.85	6.68	10.92	15.16	23.65	40.62
	L1	45					13.74	16.56	20.81	25.05	33.53	50.50
	L2	45					21.16	23.99	28.24	32.48	40.96	57.93
	Z	45					22.66	24.66	27.66	30.66	36.66	48.66
MINIMUM H = 8.95												
	Y	60					0.00	2.31	5.77	9.23	16.16	30.02
	L1	60							16.30	19.77	26.70	40.55
	L2	60							26.21	29.67	36.60	50.46
	Z	60							24.40	26.14	29.60	36.53
MINIMUM H = 13.63												
	Y	90								2.62	8.62	20.62
	L1	90									19.94	31.94
	L2	90									34.80	46.80
	Z	90									23.74	23.74
MINIMUM H = 23.74												

Additional Bending Tables (cont'd)

	DIM	ANGLE	2"	4"	6"	8"	10"	12"	15"	18"	24"	36"
1/2" IMC, Rigid, and 40 Mil PVC-Coated Rigid												
	Y	15	3.03	10.76	18.48	26.21	33.94	41.67	53.26	64.85	88.03	134.39
	L1	15	7.72	15.45	23.18	30.90	38.63	46.36	57.95	69.54	92.72	139.09
	L2	15	8.87	16.59	24.32	32.05	39.78	47.50	59.10	70.69	93.87	140.23
	Z	15	11.12	18.58	26.05	33.51	40.97	48.44	59.63	70.83	93.22	138.01
MINIMUM H = 0.95												
	Y	22.5	.77	5.98	11.21	16.44	21.66	26.89	34.73	42.57	58.25	89.60
	L1	22.5	5.20	10.43	15.66	20.88	26.11	31.34	39.17	47.01	62.69	94.05
	L2	22.5	6.92	12.15	17.38	22.60	27.83	33.06	40.89	48.73	64.41	95.77
	Z	22.5	9.07	13.90	18.73	23.56	28.38	33.21	40.46	47.70	62.18	91.15
MINIMUM H = 1.62												
	Y	30		3.49	7.49	11.49	15.49	19.49	25.49	31.49	43.49	67.49
	L1	30		7.95	11.95	15.95	19.95	23.95	29.95	35.95	47.95	71.95
	L2	30		10.24	14.24	18.24	22.24	26.24	32.24	38.24	50.24	74.24
	Z	30		11.78	15.24	18.70	22.17	25.63	30.83	36.02	46.42	67.20
MINIMUM H = 2.42												
	Y	45			3.59	6.41	9.23	12.06	16.30	20.55	29.03	46.00
	L1	45			8.30	11.13	13.95	16.78	21.02	25.27	33.75	50.72
	L2	45			11.74	14.57	17.39	20.22	24.46	28.71	37.19	54.16
	Z	45			12.13	14.13	16.13	18.13	21.13	24.13	30.13	42.13
MINIMUM H = 4.33												
	Y	60			1.42	3.73	6.04	8.34	11.81	15.27	22.20	36.06
	L1	60				8.77	11.08	13.39	16.85	20.31	27.24	41.10
	L2	60				13.35	15.66	17.97	21.44	24.90	31.83	45.69
	Z	60				12.18	13.33	14.49	16.22	17.95	21.41	28.34
MINIMUM H = 6.55												
	Y	90				.71	2.71	4.71	7.71	10.71	16.70	28.70
	L1	90						10.12	13.12	16.12	22.12	34.12
	L2	90						17.00	20.00	23.00	29.00	41.00
	Z	90						11.26	11.26	11.26	11.26	11.26
MINIMUM H = 11.26												
3/4" IMC, Rigid, and 40 Mil PVC-Coated Rigid												
	Y	15	1.86	9.58	17.31	25.04	32.77	40.49	52.08	63.68	86.86	133.22
	L1	15	7.72	15.45	23.17	30.90	38.63	46.36	57.95	69.54	92.72	139.08
	L2	15	9.19	16.91	24.64	32.37	40.09	47.82	59.41	71.00	94.19	140.55
	Z	15	12.06	19.53	26.89	34.46	41.92	49.38	60.58	71.78	94.17	138.95
MINIMUM H = 1.19												
	Y	22.5		4.85	10.08	15.31	20.53	25.76	33.60	41.44	57.12	88.47
	L1	22.5		10.42	15.65	20.88	26.10	31.33	39.17	47.01	62.69	94.04
	L2	22.5		12.62	17.85	23.08	28.30	33.53	41.37	49.21	64.89	96.24
	Z	22.5		15.01	19.84	24.67	29.49	34.32	41.57	48.81	63.29	92.26
MINIMUM H = 2.05												
	Y	30		2.33	6.33	10.33	14.33	18.33	24.33	30.33	42.33	66.33
	L1	30		7.93	11.93	15.93	19.93	23.93	29.93	35.93	47.93	71.93
	L2	30		10.86	14.86	18.86	22.86	26.86	32.86	38.86	50.86	74.86
	Z	30		13.05	16.52	19.98	23.45	26.91	32.11	37.30	47.70	68.48
MINIMUM H = 3.06												
	Y	45			2.31	5.13	7.96	10.79	15.03	19.28	27.76	44.73
	L1	45			8.24	11.07	13.90	16.73	20.97	25.21	33.70	50.67
	L2	45			12.64	15.47	18.30	21.13	25.37	29.61	38.10	55.07
	Z	45			13.76	15.76	17.76	19.76	22.76	25.76	31.76	43.76
MINIMUM H = 5.49												
	Y	60				2.28	4.59	6.90	10.36	13.83	20.75	34.61
	L1	60					10.94	13.25	16.72	20.18	27.11	40.97
	L2	60					16.81	19.12	22.58	26.05	32.98	46.83
	Z	60					15.36	16.52	18.25	19.88	23.45	30.38
MINIMUM H = 8.31												
	Y	90					.76	2.76	5.76	8.76	14.76	26.76
	L1	90							12.60	15.60	21.60	33.60
	L2	90							21.39	24.39	30.39	42.39
	Z	90							14.33	14.33	14.33	14.33
MINIMUM H = 14.33*												

*MINIMUM H = 16.62 on U-bends



Additional Bending Tables (cont'd)

	DIM	ANGLE	2"	4"	6"	8"	10"	12"	15"	18"	24"	36"
1" IMC, Rigid, and 40 Mil PVC-Coated Rigid												
	Y	15	1.08	8.81	16.52	24.25	31.97	39.70	51.29	62.88	86.07	132.43
	L1	15	7.72	15.44	23.17	30.90	38.63	46.35	57.94	69.54	92.72	139.08
	L2	15	9.59	17.32	25.04	32.77	40.50	48.23	59.82	71.41	94.59	140.95
	Z	15	12.53	20.00	27.46	34.93	42.39	49.86	61.05	72.25	94.64	139.43
MINIMUM H = 1.31												
	Y	22.5		4.13	9.35	14.58	19.81	25.03	32.87	40.71	56.39	87.75
	L1	22.5		10.42	15.64	20.87	26.09	31.32	39.16	47.00	62.68	94.04
	L2	22.5		13.22	18.45	23.68	28.90	34.13	41.97	49.81	65.49	96.84
	Z	22.5		15.69	20.52	25.35	30.18	35.01	42.25	49.49	63.98	92.95
MINIMUM H = 2.31												
	Y	30		1.58	5.58	9.58	13.58	17.58	23.58	29.58	41.58	65.58
	L1	30		7.91	11.91	15.91	19.91	23.91	29.91	35.91	47.91	71.91
	L2	30		11.66	15.66	19.66	23.66	27.66	33.66	39.66	51.66	75.66
	Z	30		13.95	17.41	20.88	24.34	27.81	33.00	38.20	48.59	69.38
MINIMUM H = 3.51												
	Y	45			1.42	4.24	7.06	9.89	14.14	18.38	26.86	43.83
	L1	45				11.01	13.83	16.66	20.91	25.15	33.63	50.60
	L2	45				16.62	19.45	22.28	26.52	30.76	39.25	56.22
	Z	45				17.11	19.11	21.11	24.11	27.11	33.11	45.11
MINIMUM H = 6.44												
	Y	60				1.17	3.48	5.79	9.25	12.71	19.64	33.49
	L1	60					10.78	13.09	16.55	20.02	26.94	40.80
	L2	60					18.27	20.58	24.04	27.50	34.43	48.29
	Z	60					17.22	18.37	20.11	21.84	25.30	32.23
MINIMUM H = 9.91												
	Y	90						1.01	4.01	7.01	13.01	25.01
	L1	90								14.93	20.93	32.93
	L2	90								26.16	32.16	44.16
	Z	90								17.49	17.49	17.49
MINIMUM H = 17.49												
1-1/4" IMC, Rigid, and 40 Mil PVC-Coated Rigid												
	Y	15		7.15	14.87	22.60	30.33	38.06	49.65	61.24	84.42	130.78
	L1	15	7.71	15.44	23.17	30.90	38.62	46.35	57.94	69.53	92.72	139.08
	L2	15	10.07	17.80	25.53	33.25	40.98	48.71	60.30	71.89	95.07	141.44
	Z	15	13.77	21.24	28.70	36.17	43.63	51.09	62.29	73.49	95.88	140.66
MINIMUM H = 1.63												
	Y	22.5		2.57	7.80	13.02	18.25	23.47	31.31	39.15	54.83	86.19
	L1	22.5		10.41	15.63	20.86	26.09	31.31	39.15	46.99	62.67	94.03
	L2	22.5		13.94	19.17	24.40	29.62	34.85	42.69	50.53	66.21	97.56
	Z	22.5		17.18	22.01	26.84	31.66	36.49	43.73	50.98	65.46	94.43
MINIMUM H = 2.88												
	Y	30		4.00	8.00	12.00	16.00	22.00	28.00	40.00	64.00	
	L1	30		11.89	15.89	19.89	23.89	29.89	35.89	47.89	71.89	
	L2	30		16.61	20.61	24.61	28.61	34.61	40.61	52.61	76.61	
	Z	30		19.16	22.62	26.09	29.55	34.75	39.94	50.33	71.12	
MINIMUM H = 4.38												
	Y	45				2.48	5.31	8.14	12.38	16.62	25.11	42.08
	L1	45					13.75	16.58	20.83	25.07	33.55	50.52
	L2	45					20.83	23.66	27.90	32.14	40.63	57.60
	Z	45					21.40	23.40	26.40	29.40	35.40	47.40
MINIMUM H = 8.06												
	Y	60					1.46	3.77	7.23	10.69	17.62	31.48
	L1	60							16.35	19.82	26.74	40.60
	L2	60							25.79	29.25	36.18	50.04
	Z	60							23.00	24.73	28.20	35.13
MINIMUM H = 11.32												
	Y	90							1.23	4.23	10.23	22.23
	L1	90									20.13	32.13
	L2	90									34.29	46.29
	Z	90									21.96	21.96
MINIMUM H = 21.96												



Additional Bending Tables (cont'd)

	DIM	ANGLE	2"	4"	6"	8"	10"	12"	15"	18"	24"	36"
1-1/2" Rigid and 40 Mil PVC-Coated Rigid												
	Y	15		5.87	13.59	21.32	29.05	36.77	48.37	59.96	83.14	129.50
	L1	15	7.71	15.44	23.17	20.90	38.62	46.35	57.94	69.53	92.72	139.08
	L2	15	9.94	17.67	25.39	33.12	40.85	48.58	60.17	71.76	94.94	141.31
	Z	15	14.50	21.97	29.43	36.89	44.36	51.82	63.02	74.21	96.61	141.39
MINIMUM H = 1.82												
	Y	22.5		1.48	6.71	11.93	17.16	22.38	30.22	38.06	53.74	85.10
	L1	22.5		10.41	15.64	20.86	26.09	31.31	39.15	46.99	62.67	94.03
	L2	22.5		13.75	18.97	24.20	29.43	34.65	42.49	50.33	66.01	97.37
	Z	22.5		17.84	22.67	27.50	32.32	37.15	44.39	51.64	66.12	95.09
MINIMUM H = 3.13												
	Y	30			3.02	7.02	11.02	15.02	21.02	27.02	39.02	63.02
	L1	30			11.90	15.90	19.90	23.90	29.90	35.90	47.90	71.90
	L2	30			16.35	20.35	24.35	28.35	34.35	40.35	52.35	76.35
	Z	30			19.75	23.21	26.68	30.14	35.34	40.53	50.92	71.71
MINIMUM H = 4.68												
	Y	45				1.65	4.48	7.31	11.55	15.79	24.28	41.25
	L1	45					13.78	16.60	20.85	25.09	33.58	50.55
	L2	45					20.45	23.28	27.52	31.77	40.25	57.22
	Z	45					21.84	23.84	26.84	29.84	35.84	47.84
MINIMUM H = 8.37												
	Y	60					0.74	3.05	6.52	9.98	16.91	30.76
	L1	60							16.41	19.87	26.80	40.66
	L2	60							25.31	28.77	35.70	49.56
	Z	60							23.28	25.01	28.47	35.40
MINIMUM H = 12.66												
	Y	90							0.75	3.75	9.75	21.75
	L1	90									20.35	32.35
	L2	90									33.70	45.70
	Z	90									21.80	21.80
MINIMUM H = 21.80												
2" Rigid and 40 Mil PVC-Coated Rigid												
	Y	15		4.42	12.15	19.87	27.60	35.33	46.92	58.51	81.69	128.06
	L1	15	7.71	15.44	23.17	30.89	38.62	46.35	57.94	69.53	92.71	139.08
	L2	15	10.27	18.00	25.73	33.46	41.18	48.91	60.50	72.09	95.27	141.64
	Z	15	15.20	22.66	30.13	37.59	45.06	52.52	63.72	74.91	97.30	142.09
MINIMUM H = 2.00												
	Y	22.5		0.24	5.47	10.70	15.92	21.15	28.99	36.83	52.51	83.86
	L1	22.5		10.40	15.63	20.85	26.08	31.31	39.15	46.99	62.66	94.02
	L2	22.5		14.24	19.47	24.70	29.92	35.15	42.99	50.83	66.51	97.86
	Z	22.5		18.71	23.54	28.36	33.19	38.02	45.26	52.51	66.99	95.96
MINIMUM H = 3.47												
	Y	30			1.84	5.84	9.84	13.84	19.84	25.84	37.84	61.84
	L1	30			11.88	15.88	19.88	23.88	29.88	35.88	47.88	71.88
	L2	30			17.00	21.00	25.00	29.00	35.00	41.00	53.00	77.00
	Z	30			20.79	24.26	27.72	31.19	36.38	41.58	51.97	71.75
MINIMUM H = 5.20												
	Y	45				0.42	3.25	6.08	10.32	14.57	23.05	40.02
	L1	45					13.72	16.55	20.79	25.04	33.52	50.49
	L2	45					21.40	24.23	28.47	32.72	41.20	58.17
	Z	45					23.26	25.26	28.26	31.26	37.26	49.26
MINIMUM H = 9.38												
	Y	60						1.68	5.14	8.61	15.54	29.39
	L1	60							16.27	19.73	26.66	40.52
	L2	60							26.51	29.97	36.90	50.76
	Z	60							25.11	26.85	30.31	37.24
MINIMUM H = 14.25												
	Y	90								1.87	7.87	19.87
	L1	90										31.80
	L2	90										47.16
	Z	90										24.72
MINIMUM H = 24.72												

Bending Shoes and Roller Supports

28008 BENDING SHOE AND ROLLER SUPPORT

1/2" to 2" Rigid Conduit
1/2" to 1-1/4" IMC Conduit

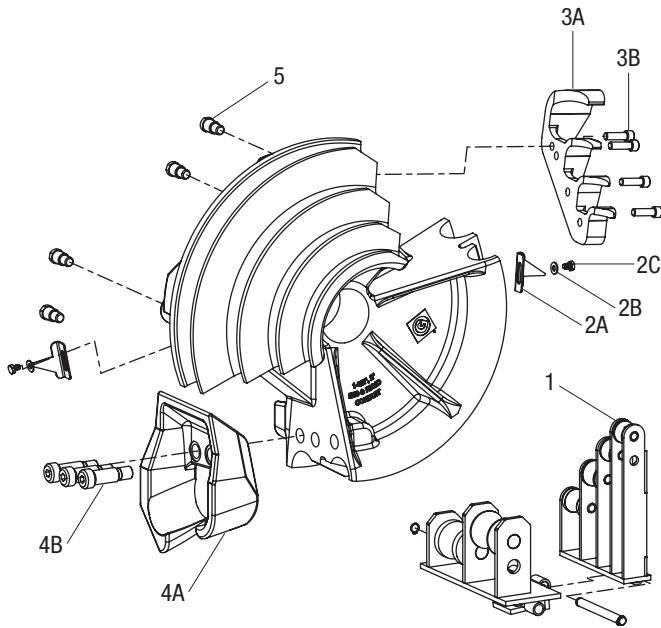

Key	Part No.	Description	Qty
	52066935	Shoe unit, 1/2"-2" rigid/IMC.....	1
	52066936	Roller support unit, 1/2"-2" rigid	1
1	52066937	Roller support, 1/2"-1-1/4".....	1
2	52065278	Pointer kit (includes one each 2A-2C)	
2A		Point.....	2
2B		Washer, 1/4" standard	2
2C		Screw, 1/4-20 x 3/8 hex hd cap.....	2
3	52065279	Hook kit, 1/2"-1-1/4" rigid/IMC	
3A		Hook, 1/2"-1-1/4" rigid/IMC.....	1
3B		Screw, 3/8-16 x 1-1/4 skt hd cap	4
4	52065280	Hook kit, 1-1/2"-2" rigid/IMC	
4A		Hook, 1-1/2"-2" rigid/IMC	1
4B		Shoulder screw, ø.75 x 1.50 x 5/8-11...3	
5	52066933	Drive pin.....	4

13934 BENDING SHOE AND ROLLER SUPPORT (555CX and 555DX)

1/2" to 2" EMT Conduit

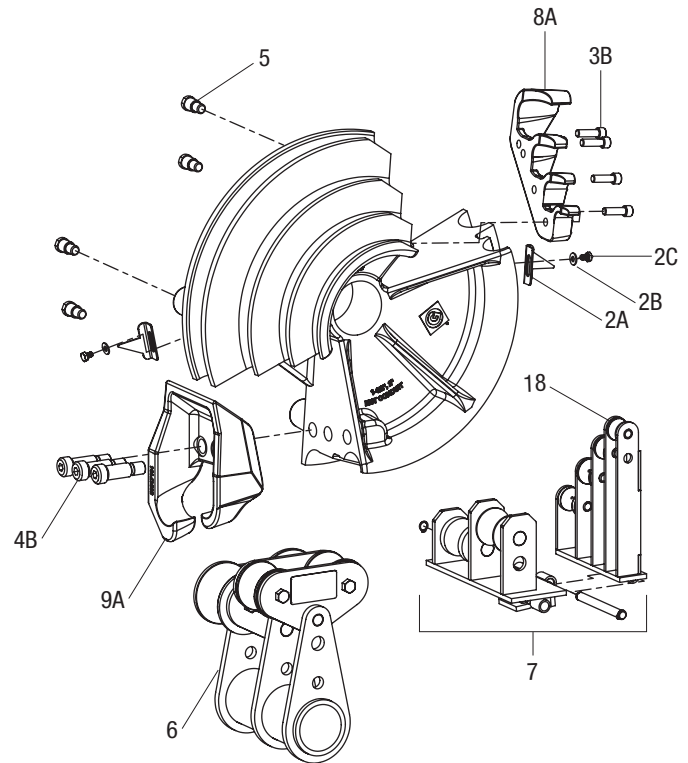

Key	Part No.	Description	Qty
	52066931	Shoe unit, 1/2"-2" EMT	1
6	52066938	Squeeze rollers, 1-1/2"-2" EMT	1
7	52066961	Roller support unit, 1/2"-2" EMT.....	1
2	52065278	Pointer kit (includes one each 2A-2C)	
2A		Point.....	2
2B		Washer, 1/4" standard	2
2C		Screw, 1/4-20 x 3/8 hex hd cap.....	2
8	52065321	Hook kit, 1/2"-1-1/4" EMT	
8A		Hook, 1/2"-1-1/4" EMT	1
3B		Screw, 3/8-16 x 1-1/4 skt hd cap	4
9	52065322	Hook kit, 1-1/2"-2" EMT	
9A		Hook, 1-1/2"-2" EMT.....	1
4B		Shoulder screw, ø.75 x 1.50 x 5/8-11...3	
5	52066933	Drive pin.....	4
18	52066934	Roller support, 1/2"-1-1/4" EMT	1

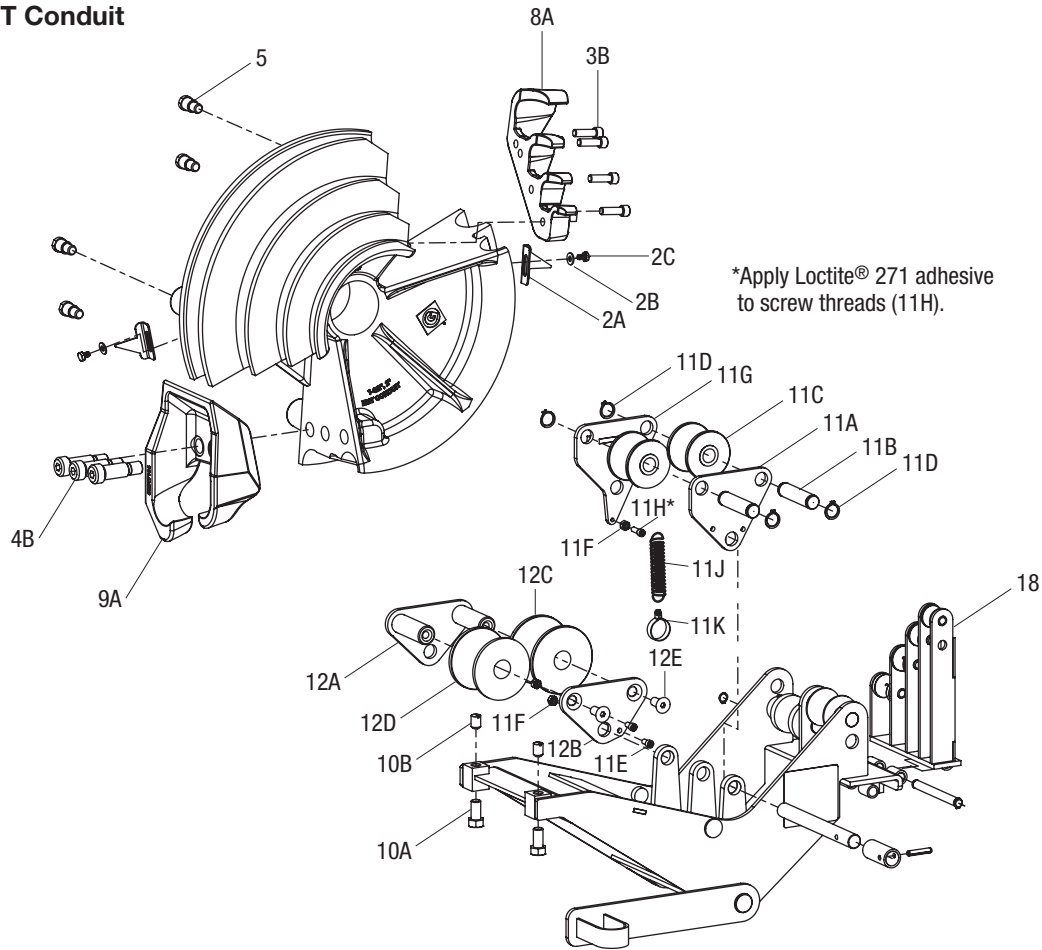
Bending Shoes and Roller Supports (cont'd)
23803 BENDING SHOE AND ROLLER SUPPORT (555C)
1/2" to 2" EMT Conduit

*Apply Loctite® 271 adhesive to screw threads (11H).

Key	Part No.	Description	Qty
	52066931	Shoe unit, 1/2"-2" EMT	1
	52066932	Bridge unit, 1/2"-2" EMT	1
2	52065278	Pointer kit (includes one each 2A-2C)	
2A		Point.....	2
2B		Washer, 1/4" standard	2
2C		Screw, 1/4-20 x 3/8 hex hd cap.....	2
8	52065321	Hook kit, 1/2"-1-1/4" EMT	
8A		Hook, 1/2"-1-1/4" EMT	1
3B		Screw, 3/8-16 x 1-1/4 skt hd cap	4
9	52065322	Hook kit, 1-1/2"-2" EMT	
9A		Hook, 1-1/2"-2" EMT.....	1
4B		Shoulder screw, ø.75 x 1.50 x 5/8-11 ...	3
5	52066933	Drive pin.....	4
10	52065273	Screw kit (includes one each 10A-10B)	
10A		Screw, 1/2-13 x 1 hex hd cap.....	2
10B		Screw, 1/2-13 x 3/4 slotted set.....	2

Key	Part No.	Description	Qty
11	52065274	Roller kit, 1-1/2" EMT	
11A		Pivot plate	1
11B		Pin, 1-1/2" EMT roller	2
11C		Roller, 1-1/2" EMT.....	2
11D		Retaining ring, Truarc #5160 EX	4
11F		Hex nut, 1/4-20.....	1
11G		Pivot plate, rear.....	1
11H		Screw, 1/4-20 x 3/4 skt hd cap.....	1
11J		Spring, extension	1
11K		Clamp, loop type	1
12	52065275	Roller kit, 2" EMT	
12A		Support weldment, 2" EMT	1
12B		Plate, 2" EMT	1
12C		Roller, 2" EMT back (larger OD)	1
12D		Roller, 2" EMT front (smaller OD)	1
12E		Screw, 7/16-14 x 1 flat hd cap.....	2
11E		Screw, 1/4-20 x 1/2 skt hd cap.....	2
11F		Hex nut, 1/4-20.....	2
18	52066934	Roller support, 1/2"-1-1/4" EMT	1

Bending Shoes and Roller Supports

01323 BRIDGE UNIT (555C)

1/2" to 2" IMC and Rigid Conduit

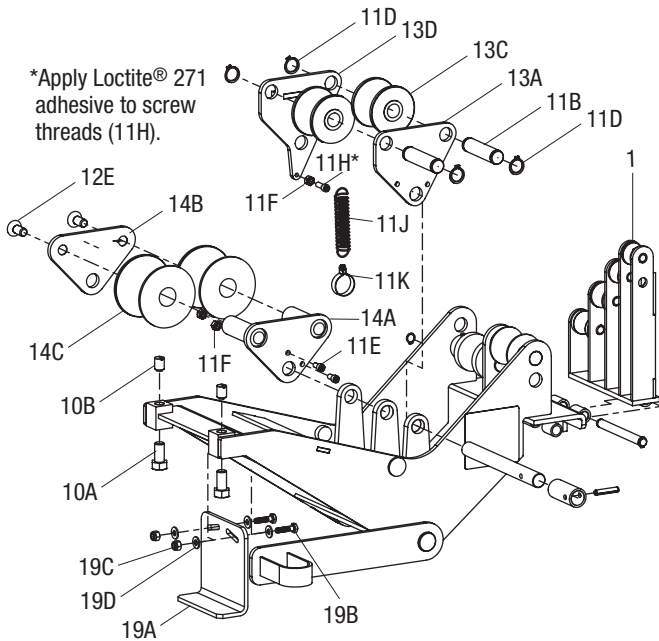

*Apply Loctite® 271 adhesive to screw threads (11H).

Key	Part No.	Description	Qty
	52064757	Bridge unit, 1/2"-2" IMC/rigid.....	1
10	52065273	Screw kit (includes one each 10A-10B)	
10A		Screw, 1/2-13 x 1 hex hd cap.....	2
10B		Screw, 1/2-13 x 3/4 slotted set.....	2
13	52065276	Roller kit, 1-1/2" IMC	
13A		Pivot plate	1
13C		Roller, 1-1/2" IMC	2
13D		Pivot plate, rear.....	1
11B		Pin, 1-1/2" EMT roller	2
11D		Retaining ring, Truarc #6160 EX	4
11F		Hex nut, 1/4-20.....	1
11H		Screw, 1/4-20 x 3/4 skt hd cap.....	1
11J		Spring, extension.....	1
11K		Clamp, loop type	1
14	52065277	Roller kit, 2" IMC	
14A		Support weldment, 2" IMC	1
14B		Plate, 2" IMC.....	1
14C		Roller, 2" IMC.....	2
12E		Screw, 7/16-14 x 1 flat hd cap.....	2
11E		Screw, 1/4-20 x 1/2 skt hd cap.....	2
11F		Hex nut, 1/4-20.....	2
1	52066937	Roller support, 1/2"-1-1/4" IMC/rigid...1	
19	52066949	Plate kit (includes 19A-19D)	
19A		Plate, bridge trap	1
19B		Screw, 1/4-20 x 1-1/4 hex hd cap	2
19C		Lock nut, 1/4-20	2
19D		Washer, 1/4" standard	4

12586 PVC BENDING SHOE AND ROLLER SUPPORT

1/2" to 2" 40 MIL PVC-Coated Rigid Conduit

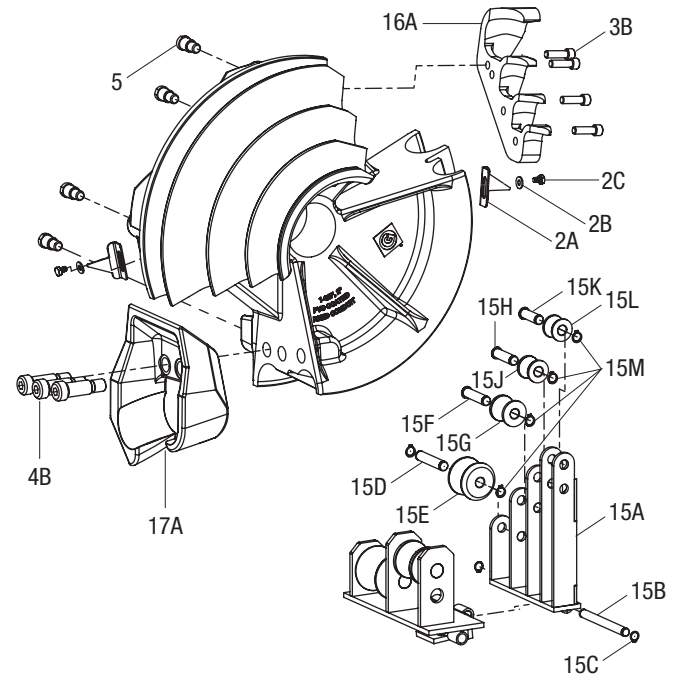

Key	Part No.	Description	Qty
	52066939	Shoe unit, 1/2"-2" PVC-coated rigid	
	52066940	Roller support unit, 1/2"-2"	
15	52065272	Roller support, 1/2"-1-1/4"	
15A		Support weldment	1
15B		Pivot pin.....	1
15C		Retaining ring, Truarc #5160-42 EX.....	2
15D		Axle, 1-1/4" roller	1
15E		Roller, 1-1/4"	1
15F		Axle, 1" roller.....	1
15G		Roller, 1".....	1
15H		Axle, 3/4" roller	1
15J		Roller, 3/4"	1
15K		Axle, 1/2" roller	1
15L		Roller, 1/2"	1
15M		Retaining ring, Truarc #5160-50 EX.....	5
2	52065278	Pointer kit (includes one each 2A-2C)	
2A		Point.....	2
2B		Washer, 1/4" standard	2
2C		Screw, 1/4-20 x 3/8 hex hd cap.....	2
16	52065323	Hook kit, 1/2"-1-1/4" PVC	
16A		Hook, 1/2"-1-1/4" PVC.....	1
3B		Screw, 3/8-16 x 1-1/4 skt hd cap	4
17	52065324	Hook kit, 1-1/2"-2" PVC	
17A		Hook, 1-1/2"-2" PVC.....	1
4B		Shoulder screw, ø.75 x 1.50 x 5/8-11 ...	3
5	52066933	Drive pin.....	4





4455 Boeing Drive • Rockford, IL 61109-2988 • USA • 815-397-7070
An ISO 9001 Company • Greenlee Textron Inc. is a subsidiary of Textron Inc.

www.greenlee.com

USA Tel: 800-435-0786
Fax: 800-451-2632

Canada Tel: 800-435-0786
Fax: 800-524-2853

International Tel: +1-815-397-7070
Fax: +1-815-397-9247