

# Guia rápido ToneRanger

## Isolar e localizar uma blindagem aberta

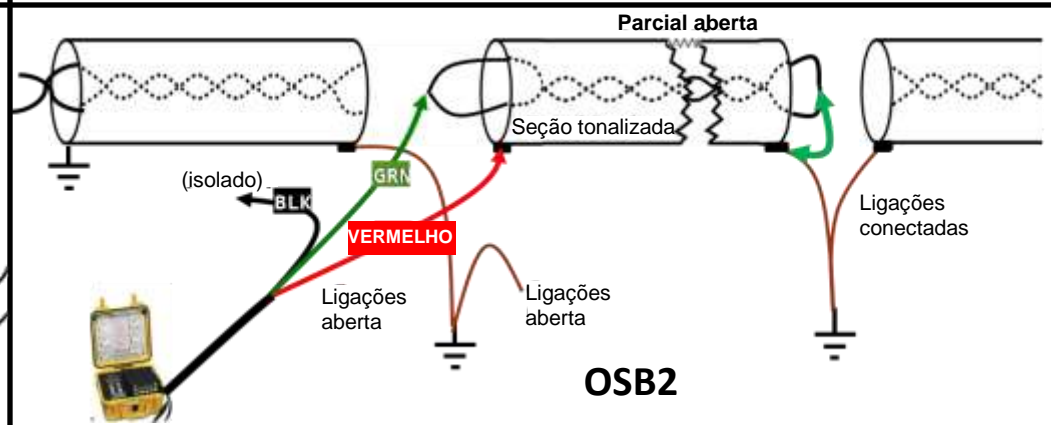

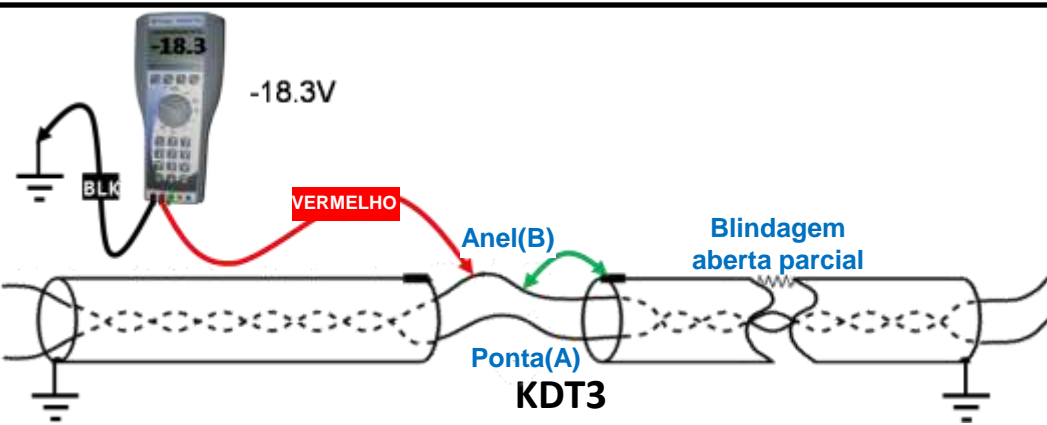
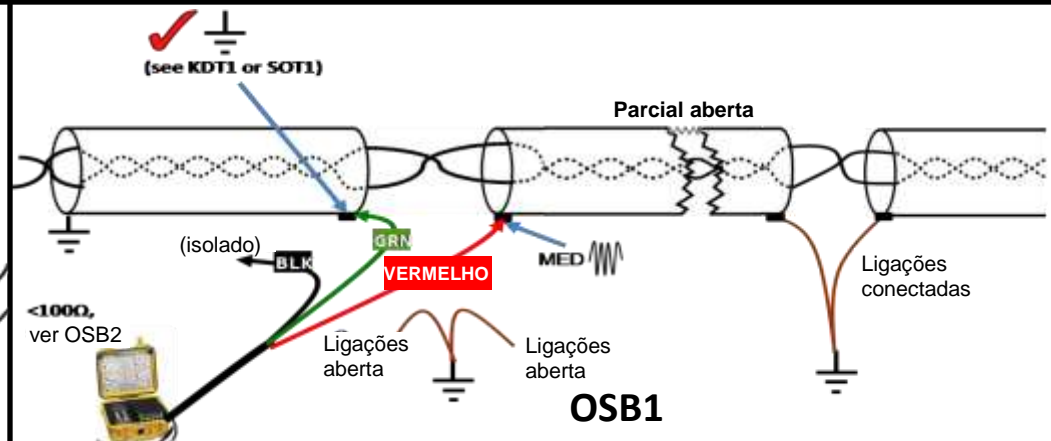
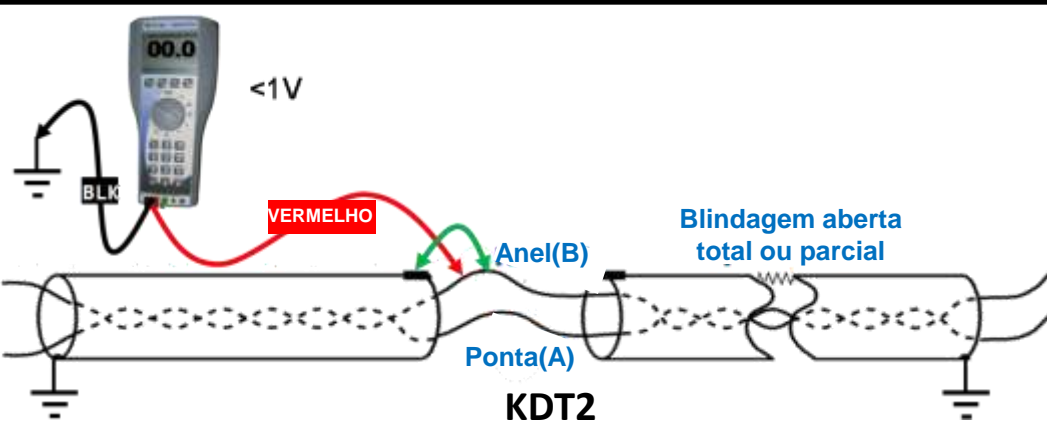
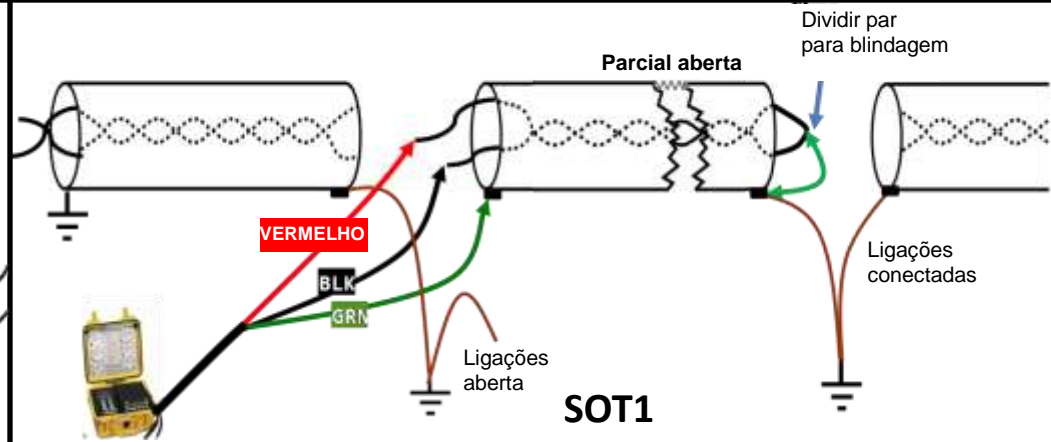
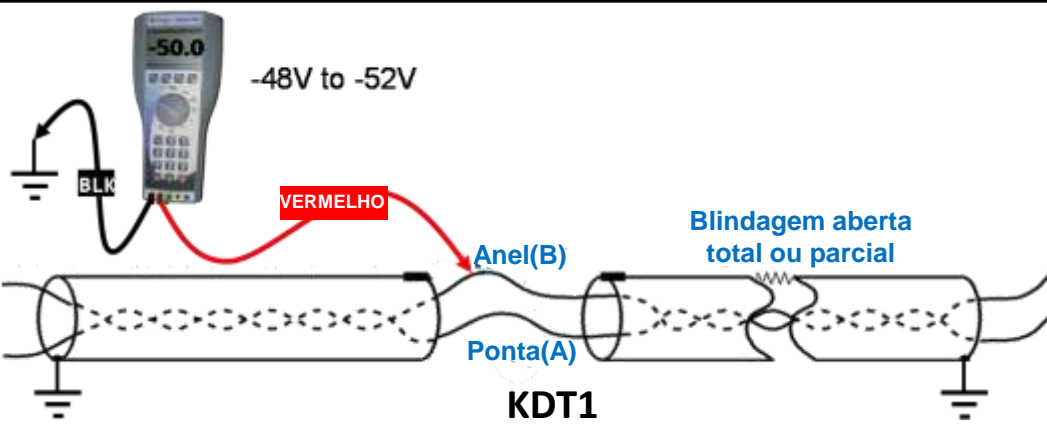
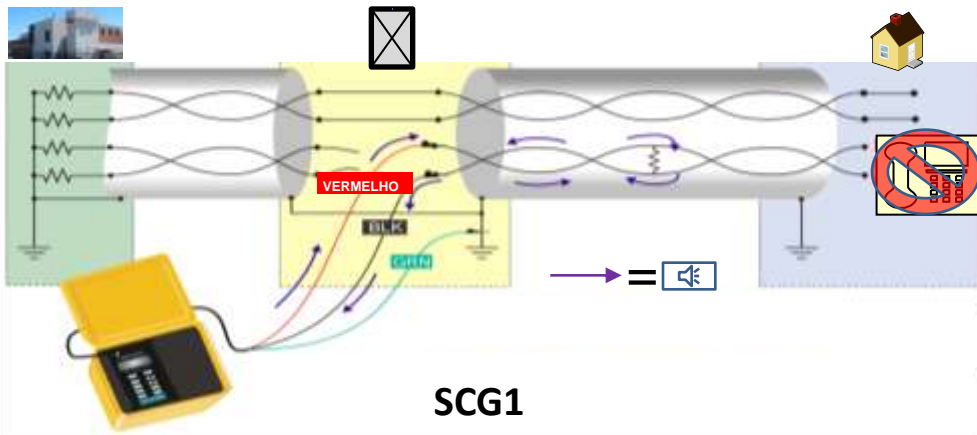

SCG1

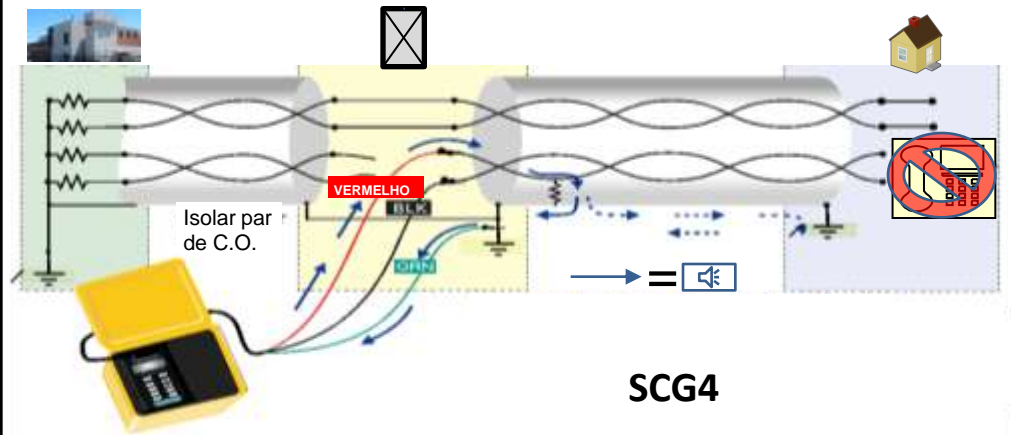

SCG4

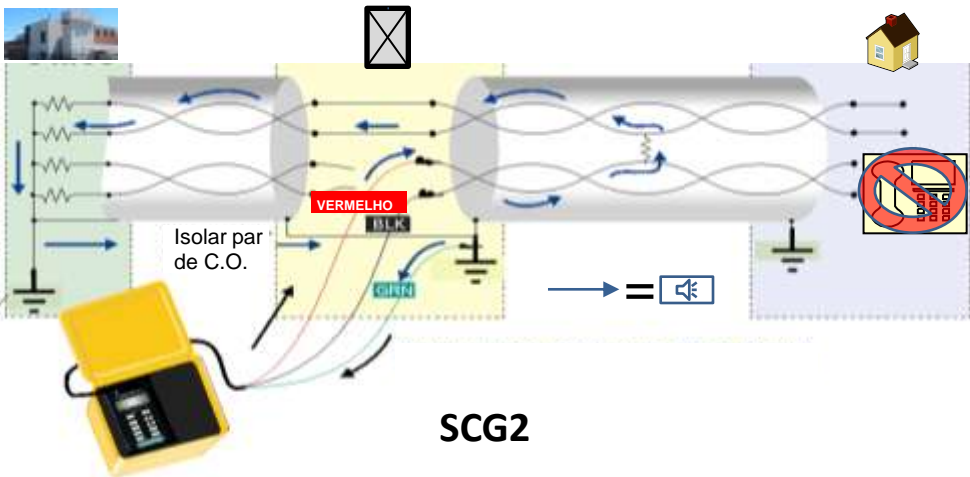

SCG2

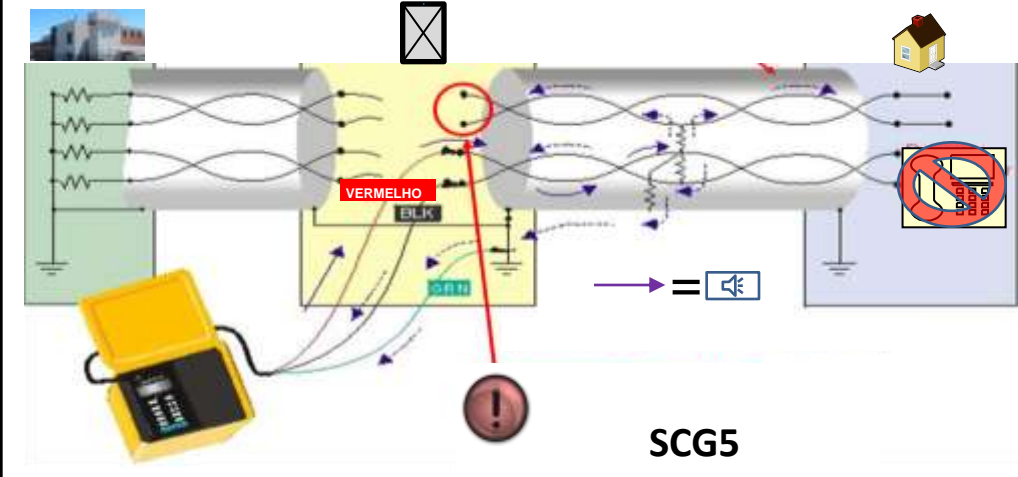

SCG5

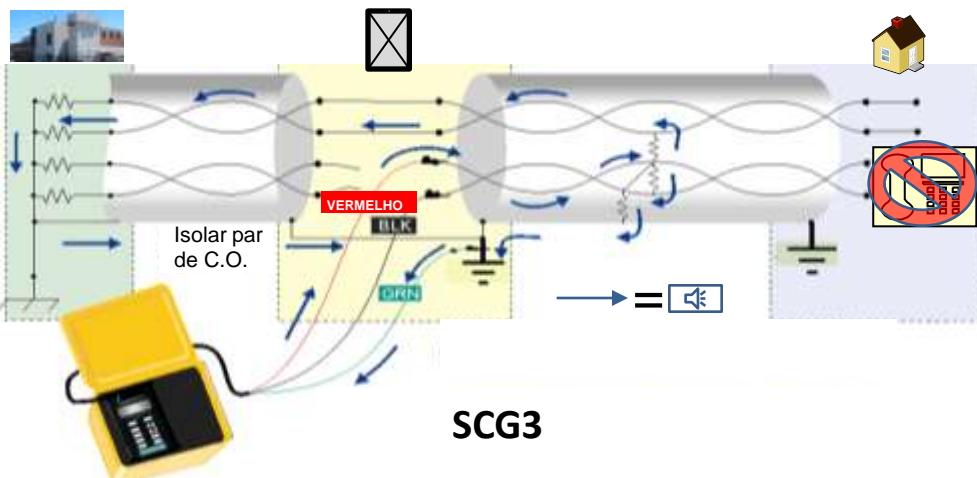

SCG3

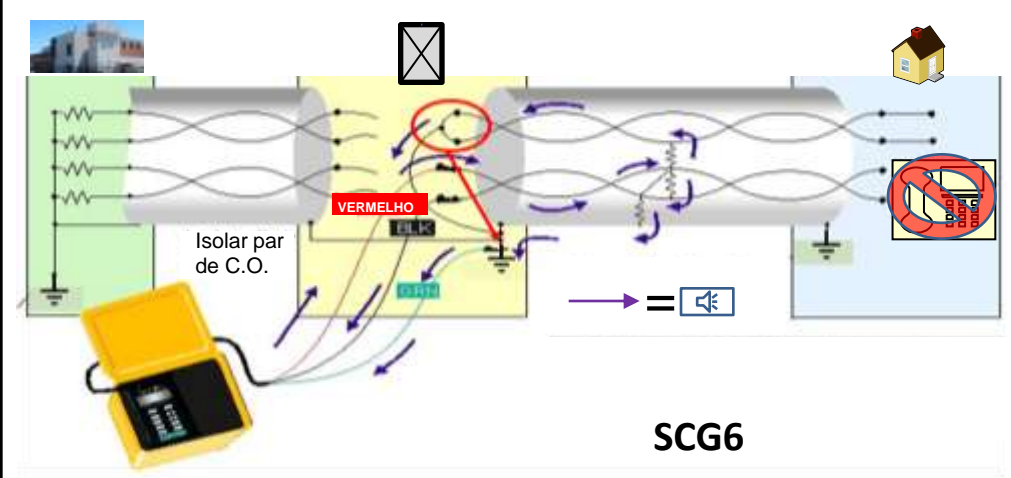

SCG6

# Tabela do intervalo de falhas localizáveis

Fault [Falha]	Aéreo Max.	Subterrâneo Max.	Profundidade Max.
Short [Curto]	50k $\Omega$	20k $\Omega$	1½ ft. [.5m]
Cross [Cruzado]	100k $\Omega$	20k $\Omega$	2½ ft. [.8m]
Ground [Terra]	100k $\Omega$	50k $\Omega$	5 ft. [1.5m]
Split [Transposto]	Strap	Strap	3 ft. [1m]
Wet Splice [Úmido]	100k $\Omega$	100k $\Omega$	5 ft. [1.5m]

## ID do par



PID1

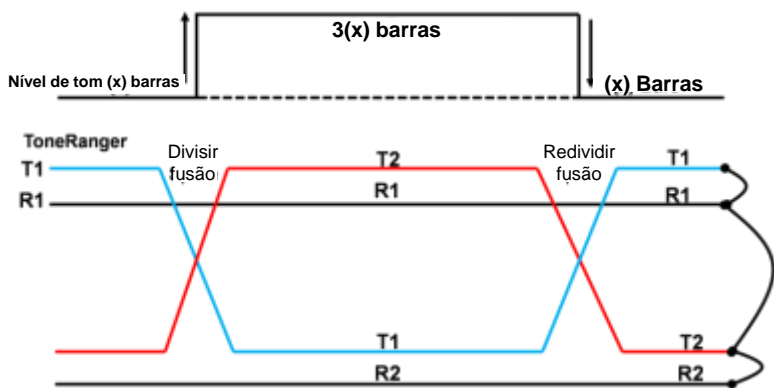

Dividir



PID2

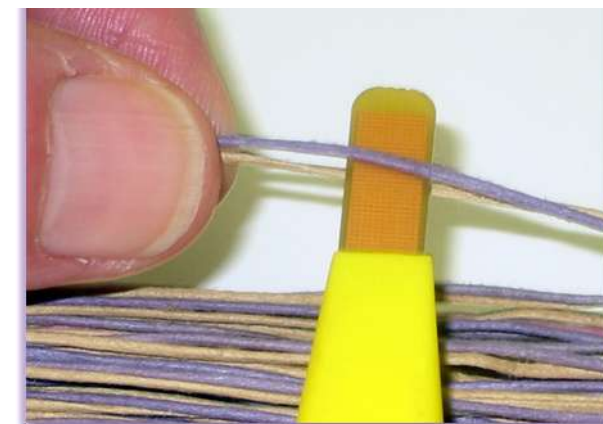

PID3

