

OPERATION MANUAL

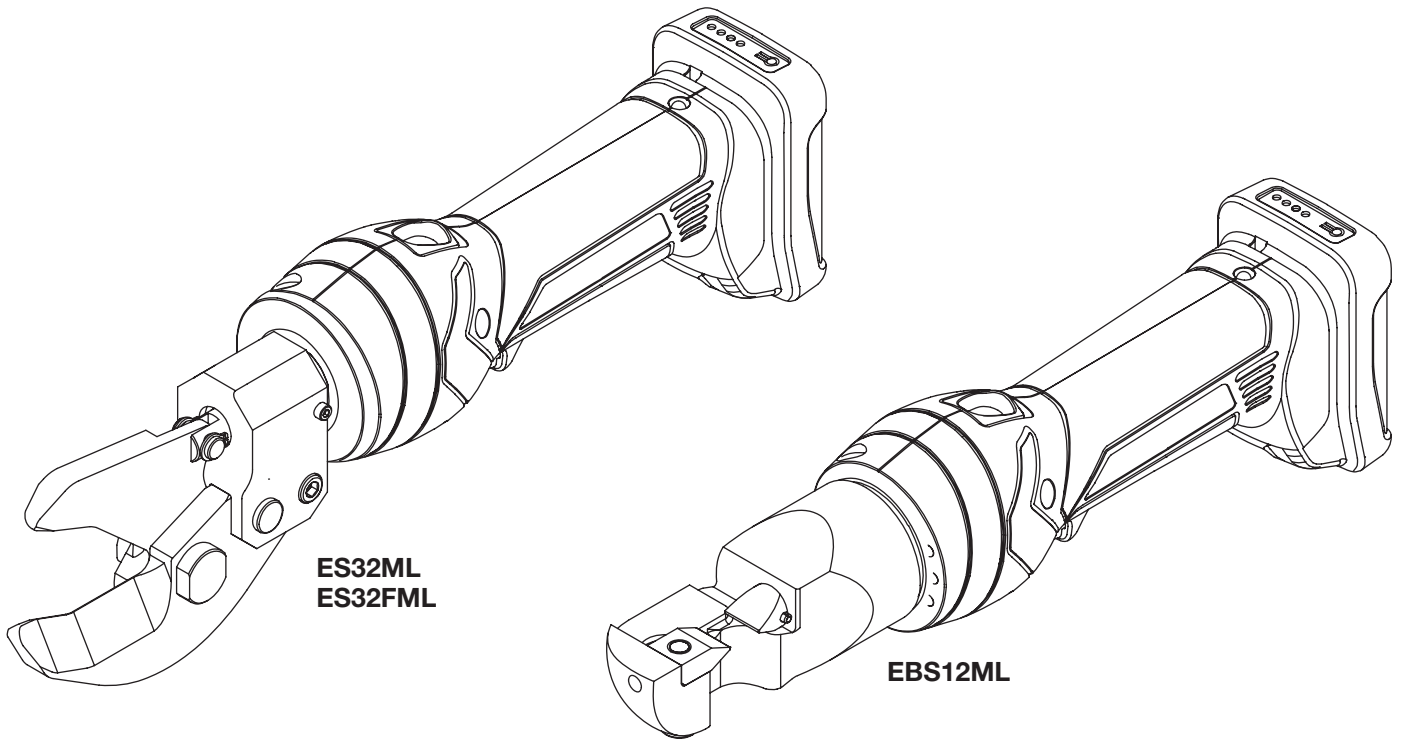

Battery-powered Micro Cutters



Read and understand all of the instructions and safety information in this manual before operating or servicing this tool.

Register this product at www.greenlee.com

Table of Contents

Description	2
Safety	2
Purpose of this Manual	2
Important Safety Information	3-4
Identification	5
Specifications	6
Battery and Charger	7
Operation.....	8-9
Maintenance.....	10
Troubleshooting.....	11

Description

Greenlee's Battery-powered Micro Cutters are hand-held, self-contained cutting tools intended to cut the following:

- **ES32ML Cable Cutter:** Aluminum and copper cable only.
- **ES32FML Cable Cutter:** Fine stranded cable only.
- **EBS12ML Single Use Lock Cutter and Bolt Cutter:** Bolts, steel rods, one-time disposable locks, and sea container seals or similar soft metal devices.

These tools are protected by U.S. Patent No. 6,276,186, 6,401,515, 6,718,870, 7,086,979, and 7,254,982.

Safety

Safety is essential in the use and maintenance of Greenlee tools and equipment. This manual and any markings on the tool provide information for avoiding hazards and unsafe practices related to the use of this tool. Observe all of the safety information provided.

Purpose of this Manual

This manual is intended to familiarize all personnel with the safe operation and maintenance procedures for the following Greenlee tools:

- ES32ML Battery-powered Cable Cutter
- ES32FML Battery-powered Cable Cutter
- EBS12ML Battery-powered Single Use Lock Cutter and Bolt Cutter

Keep this manual available to all personnel.

Replacement manuals are available upon request at no charge at www.greenlee.com.



Do not discard this product or throw away!

For recycling information, go to www.greenlee.com.

All specifications are nominal and may change as design improvements occur. Greenlee Textron Inc. shall not be liable for damages resulting from misapplication or misuse of its products.

KEEP THIS MANUAL

IMPORTANT SAFETY INFORMATION



SAFETY ALERT SYMBOL

This symbol is used to call your attention to hazards or unsafe practices which could result in an injury or property damage. The signal word, defined below, indicates the severity of the hazard. The message after the signal word provides information for preventing or avoiding the hazard.

⚠️ DANGER

Immediate hazards which, if not avoided, **WILL** result in severe injury or death.

⚠️ WARNING

Hazards which, if not avoided, **COULD** result in severe injury or death.

⚠️ CAUTION

Hazards or unsafe practices which, if not avoided, **MAY** result in injury or property damage.

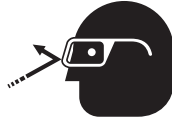
	<p style="text-align: center;">⚠️ WARNING</p> <p>Wear eye protection when operating or servicing this tool.</p> <p>Failure to wear eye protection could result in serious eye injury from flying debris or hydraulic oil.</p>
--	--

	<p style="text-align: center;">⚠️ WARNING</p> <p>Skin injection hazard:</p> <p>Do not use hands to check for oil leaks. Oil under pressure easily punctures skin. If injured, seek medical attention immediately to remove oil.</p> <p>Failure to observe this warning could result in serious injury, gangrene, or death.</p>
--	---

	<p style="text-align: center;">⚠️ WARNING</p> <p>Do not use solvents or flammable liquids to clean the tool body. Solvents or flammable liquids could ignite and cause serious injury or property damage.</p>
--	--

	<p style="text-align: center;">⚠️ WARNING</p> <p>Read and understand all of the instructions and safety information in this manual before operating or servicing this tool.</p> <p>Failure to observe this warning could result in severe injury or death.</p>
---	---

	<p style="text-align: center;">⚠️ WARNING</p> <p>Cutting hazard:</p> <ul style="list-style-type: none"> • Remove battery before changing dies, adapters, or jaws. • Keep hands away from the cutting head when cutting. <p>Failure to observe these warnings could result in severe injury or death.</p>
--	---

	<p style="text-align: center;">⚠️ WARNING</p> <p>Electric shock hazard:</p> <p>This tool is not insulated. When using this unit near energized electrical lines, use proper personal protective equipment.</p> <p>Failure to observe this warning could result in severe injury or death.</p>
---	--

IMPORTANT SAFETY INFORMATION

⚠ WARNING

Do not dispose of batteries in a fire. They will vent fumes and may explode.

Failure to observe this warning could result in severe injury from harmful fumes or burns from flying debris.

⚠ WARNING

Inspect tool and blades before use. Replace any worn or damaged parts. A damaged or improperly assembled tool can break and strike nearby personnel.

Failure to observe this warning could result in severe injury or death.

⚠ CAUTION

- Do not twist work piece or tool during cutting operation. Blade failure could result.
- This tool is not designed for continuous use. After LED indicator (red) indicates tool has become too hot, allow the cutting tool to cool for 15 minutes.
- Do not secure this tool in a vise. This tool is designed for hand-held operation.
- This tool may be used in damp or wet environments; however, air-drying is recommended before use if the tool becomes soaked. Damage may result when the tool is operated prior to thorough drying when electrical components are soaked.
- Use this tool for the manufacturer's intended purpose only.

Failure to observe these precautions may result in injury or property damage.

⚠ CAUTION

Do not allow anything to contact the battery terminals.

- Do not immerse the batteries in liquid. Liquid may create a short circuit and damage the battery. If batteries are immersed, contact your service center for proper handling.
- Do not place the battery into a pocket, tool pouch, or tool box with conductive objects. Conductive objects may create a short circuit and damage the battery.
- Do not place a battery on moist ground or grass. Moisture may create a short circuit and damage the battery.

Failure to observe these precautions may result in injury or property damage.

⚠ CAUTION

- Do not store the battery at more than 122 °F (50 °C) or less than -4 °F (-20 °C). Damage to the battery can result.
- Do not use another manufacturer's charger. Other manufacturers' chargers may overcharge and damage the battery.
- Do not attempt to open the battery. It contains no user-serviceable parts.

Failure to observe these precautions may result in injury or property damage.

⚠ CAUTION

Do not perform any service or maintenance other than as described in this manual. Injury or damage to the tool may result.

Failure to observe this precaution may result in injury and property damage.

Note: Keep all decals clean and legible, and replace when necessary.

Identification

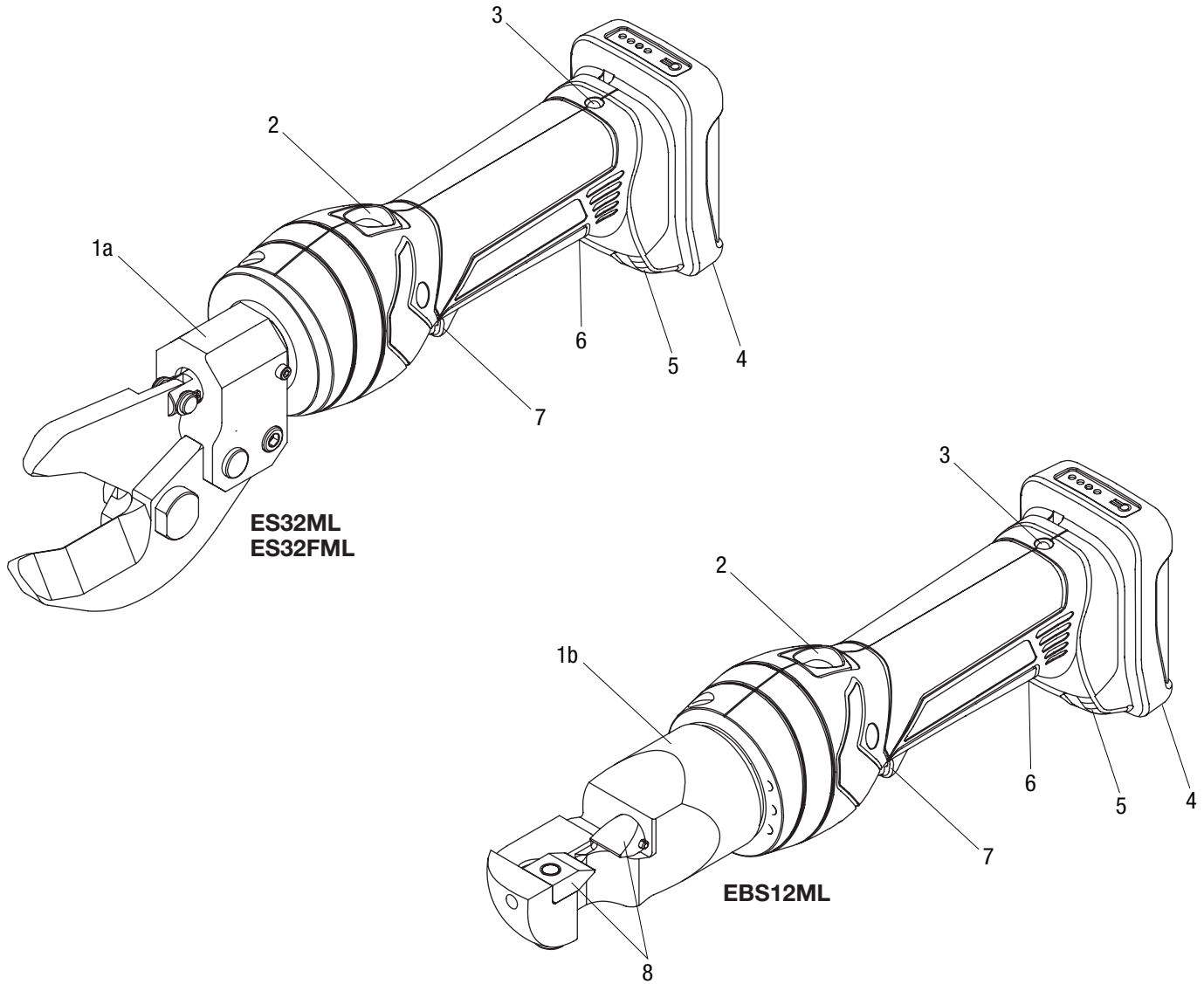

Battery-powered Micro Cutters

- | | |
|------------------------|-----------------------------|
| 1a. Cutting Head | 5. Battery Lock |
| 1b. Bolt Cutter Head | 6. LED Work Light (white) |
| 2. Retract Button | 7. Trigger |
| 3. LED Indicator (red) | 8. Cutting Blades (EBS12ML) |
| 4. Battery Cartridge | |

Specifications

ES32ML

Cutting Tool	
Length (with battery).....	14.09" (358 mm)
Width	2.80" (71 mm)
Depth.....	4.33" (110 mm)
Weight (with battery).....	4.0 lb (1.8 kg)
Cutting Capacity	
Maximum Cable Size with 2 Cutting Cycles	
Copper600 kcmil (MCM) (304 mm ²)
Maximum Cable Size with 1 Cutting Cycle	
Copper400 kcmil (MCM) (240 mm ²)
Aluminum750 kcmil (MCM) (380 mm ²)

ES32FML

Cutting Tool	
Length (with battery).....	14.09" (358 mm)
Width	2.80" (71 mm)
Depth.....	4.33" (110 mm)
Weight (with battery).....	4.0 lb (1.8 kg)
Cutting Capacity	
Fine Stranded Copper Cable only	ø1.25" (31.8 mm) max.
<i>Not for cutting regular stranded cable or steel</i>	

EBS12ML

Cutting Tool	
Length (with battery).....	13.07" (332 mm)
Width	2.80" (71 mm)
Depth.....	3.78" (96 mm)
Weight (with battery).....	4.0 lb (1.8 kg)
Cutting Capacity	
Common Bolt	1/2" dia.
Grade 5 Bolt	7/16" dia.
Grade 8 Bolt	5/16" dia.
Threaded Rod.....	1/2" dia.
One-Time Disposable Lock	4 AWG Alumoweld
Boa Lock	BL-9
Grade 40 Rebar	3/8" dia.
Steel Rod	3/8" dia. (1/2" dia. using 2 cycles)
Ground Rod	3/8" dia. (1/2" dia. using 2 cycles)
Copper and Aluminum Cable	2/0 AWG
ACSR.....	3/0 AWG Pigeon (4/0 AWG Penguin using two cuts)
Guy Strand	5/16" dia. (3/8" dia. using two cycles)
EHS Guy Strand	5/16" dia.
Aircraft Cable.....	1/4" dia.
<i>Not recommended for fine stranded cables.</i>	

All Models

Cutting Tool	
Hydraulic Oil	52057878 biodegradable hydraulic fluid
Recommended Operating Temperature Range.....	5 °F to 122 °F (-15 °C to 50 °C)
Battery Charger.....	Read the instructions supplied with the battery charger

52068603 Charger, 10.8 V lithium-ion batteries, 110 V
--

Battery and Charger

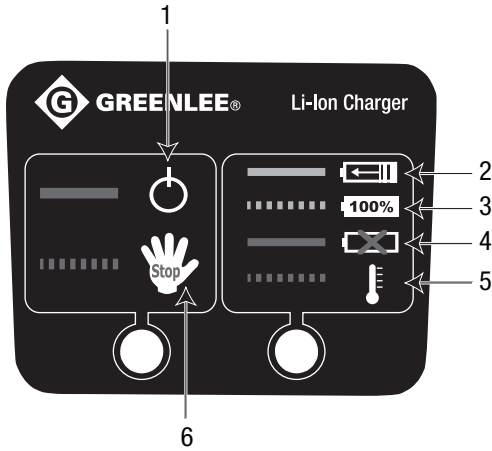

1. Charger is plugged into socket.
2. Battery is charging.
3. Battery is fully charged.
4. Battery is defective.
5. Battery is too hot or too cold.
6. Charger is defective.

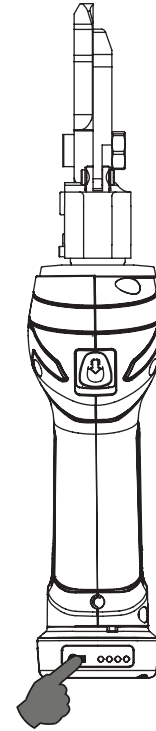

⚠ CAUTION

Remove the battery before unplugging the charger from the receptacle to prevent the battery from discharging and potentially burning up. Failure to observe this precaution may result in injury and property damage.

% Charge Remaining

100%	
75%	
50%	
25%	
0%	

Operation

⚠ WARNING
<p>Inspect tool and blades before use. Replace any worn or damaged parts. A damaged or improperly assembled tool can break and strike nearby personnel.</p> <p>Failure to observe this warning could result in severe injury or death.</p>

	⚠ WARNING
	<p>Cutting hazard:</p> <ul style="list-style-type: none"> • Remove battery before changing dies, adapters, or jaws. • Keep hands away from the cutting head when cutting. <p>Failure to observe these warnings could result in severe injury or death.</p>

	⚠ WARNING
	<p>Electric shock hazard:</p> <p>This tool is not insulated. When using this unit near energized electrical lines, use proper personal protective equipment.</p> <p>Failure to observe this warning could result in severe injury or death.</p>

⚠ CAUTION
<ul style="list-style-type: none"> • Do not twist work piece or tool during cutting operation. Blade failure could result. • This tool is not designed for continuous use. After LED indicator (red) indicates tool has become too hot, allow the cutting tool to cool for 15 minutes. • Do not secure this tool in a vise. This tool is designed for hand-held operation. • This tool may be used in damp or wet environments; however, air-drying is recommended before use if the tool becomes soaked. Damage may result when the tool is operated prior to thorough drying when electrical components are soaked. • Use this tool for the manufacturer's intended purpose only. <p>Failure to observe these precautions may result in injury or property damage.</p>

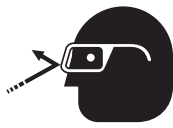
	⚠ WARNING
	<p>Wear eye protection when operating or servicing this tool.</p> <p>Failure to wear eye protection could result in serious eye injury from flying debris or hydraulic oil.</p>

Operation (cont'd)

Charging the Battery







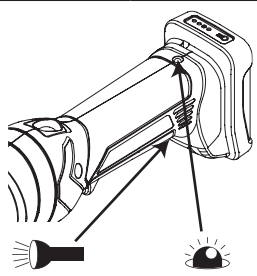

Read the instructions supplied with the battery charger.

LED Work Light (white)

This LED automatically turns on when the trigger is pulled. It remains on for 10 seconds after the trigger is released.

LED Indicator (red)

This tool is equipped with a special circuit board incorporating several important features to inform the user about the current status of the unit. The LED signals in the following cases:

		When	What it means
	 2 x	After inserting the battery	Battery is inserted in tool
	 20 sec	After working cycle	Low battery
	 20 sec/2 Hz		Contact Greenlee service
 20 sec/5 Hz	 20 sec/5 Hz		Tool has become too hot
 1 x	 1 x	After interruption	Error – manual interruption of cutting cycle prior to completion

Important Features of All Models

- The hydraulic unit incorporates an automatic retraction, which returns the piston and movable blade to the starting position when the maximum cutting force is achieved.
- The unit is equipped with a special brake, which stops the forward motion of the piston when the trigger is released.
- The cutting heads have been designed to turn 350° around the longitudinal axis in order to gain the best access to tight corners and other difficult working areas.

Cutting Procedure—ES32ML and ES32FML

1. Insert the cable to be cut into the cutting head.
2. Pull the trigger to make the cut.
3. Hold the trigger down until the cutting tool achieves pressure relief, which is accompanied by an audible “pop”.
4. The cutting tool returns automatically.

Note: If it is necessary to retract the ram before a cutting cycle is completed, push the retract button. Pushing the retract button will result in the complete retraction of the ram.

Note (ES32ML only): For some cables more than one cutting cycle may be required to complete the cut. If the cable is not fully cut during the first cycle, move the cable as close to the jaw pivot as possible and cycle the tool again.

Cutting Procedure—EBS12ML

1. Check cutting head to ensure the piston and movable blade are fully retracted. If necessary, pull the retract slide in the direction of the arrow.
2. After positioning the wire/bolt between the open cutting blades, actuate the trigger to start the cutting cycle.

Note: Do not twist work piece or tool during cutting operation. Blade failure could result.

Note: The cutting process can be interrupted at any moment by releasing the trigger. By actuating the retract slide, the piston and movable blade will return to the starting position.

Maintenance

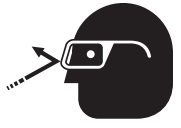
	⚠ WARNING
	<p>Wear eye protection when operating or servicing this tool.</p> <p>Failure to wear eye protection could result in serious eye injury from flying debris or hydraulic oil.</p>

	⚠ WARNING
	<p>Skin injection hazard:</p> <p>Do not use hands to check for oil leaks. Oil under pressure easily punctures skin. If injured, seek medical attention immediately to remove oil.</p> <p>Failure to observe this warning could result in serious injury, gangrene, or death.</p>

	⚠ WARNING
	<p>Do not use solvents or flammable liquids to clean the tool body. Solvents or flammable liquids could ignite and cause serious injury or property damage.</p>

	⚠ WARNING
	<p>Cutting hazard:</p> <p>Keep hands away from the cutting head when cutting.</p> <p>Failure to observe these warnings could result in severe injury or death.</p>

IMPORTANT
Relief valve adjustments must be done by an authorized service center.

Daily

Before use:

1. Inspect the tool for wear or damage, such as cracks, gouges, or chips.
2. Inspect the tool for damage or leaks.
3. Inspect the rotation of the head assembly. Fully retract the ram. The head should rotate no more than 350°. If damage is detected, contact Greenlee customer service at 800-435-0786 for warranty service or repair.

After use:

1. Use a damp cloth and mild detergent to clean the housing. Allow the housing to dry.
2. Fully retract the ram. Place the tool in the carrying case and store in a cool, dry place.
3. If necessary, recharge the batteries. Refer to the instructions supplied with the battery charger.

Monthly

1. Thoroughly clean all surfaces.
2. Check the oil level.

Annually or After 10,000 Cuts

1. Replace the hydraulic oil.
2. Contact Greenlee customer service at 800-435-0786 for warranty service or repair.

Checking the Oil Level

1. Remove the screws holding the housing cover together.
2. Point the cutting head downward and remove the oil reservoir plug. Fill reservoir if necessary.
3. Replace the oil plug and housing cover.

Troubleshooting

Before You Begin

1. Make sure that the battery is charged. Recheck the battery after several minutes to make sure the battery is holding its charge.
2. Use a **nonflammable** contact cleaner or pencil eraser to clean the electrical contacts on the battery and tool.
3. Reinstall the battery and check the tool again.

Problem	Possible Cause	Probable Remedy
Tool is inoperative.	Dirt, contaminants, etc., in ram area of tool.	Clean tool.
	Tool components worn or damaged.	Contact Greenlee customer service at 800-435-0786 for warranty service or repair.
Motor is inoperative.	Low or uncharged battery.	Try known charged battery. Inoperative battery may be discharged or may have reached life expectancy.
	Broken switch components.	Contact Greenlee customer service at 800-435-0786 for warranty service or repair.
Motor runs but tool will not complete a cycle.	Oil level low.	Contact Greenlee customer service at 800-435-0786 for warranty service or repair.
	Air in hydraulic system.	Pull trigger and hold retract button simultaneously. Run for approximately 10 seconds, and then attempt to cut. If unsuccessful, contact Greenlee customer service at 800-435-0786 for warranty service or repair.
	Cold oil.	Pull trigger and hold retract button simultaneously to warm oil. Store tool in warm area.
Dies stop during operation.	Oil level low.	Contact Greenlee customer service at 800-435-0786 for warranty service or repair.
	Air in hydraulic system.	Pull trigger and hold retract button simultaneously. Hold for approximately 10 seconds.
LED glows for 20 seconds.	Battery charge low.	Charge or replace battery.
Tool loses oil.	Damaged internal seal.	Contact Greenlee customer service at 800-435-0786 for warranty service or repair.



4455 Boeing Drive • Rockford, IL 61109-2988 • USA • 815-397-7070
An ISO 9001 Company • Greenlee Textron Inc. is a subsidiary of Textron Inc.
www.greenlee.com

USA Tel: 800-435-0786
Fax: 800-451-2632

Canada Tel: 800-435-0786
Fax: 800-524-2853

International Tel: +1-815-397-7070
Fax: +1-815-397-9247