

SERVICE MANUAL

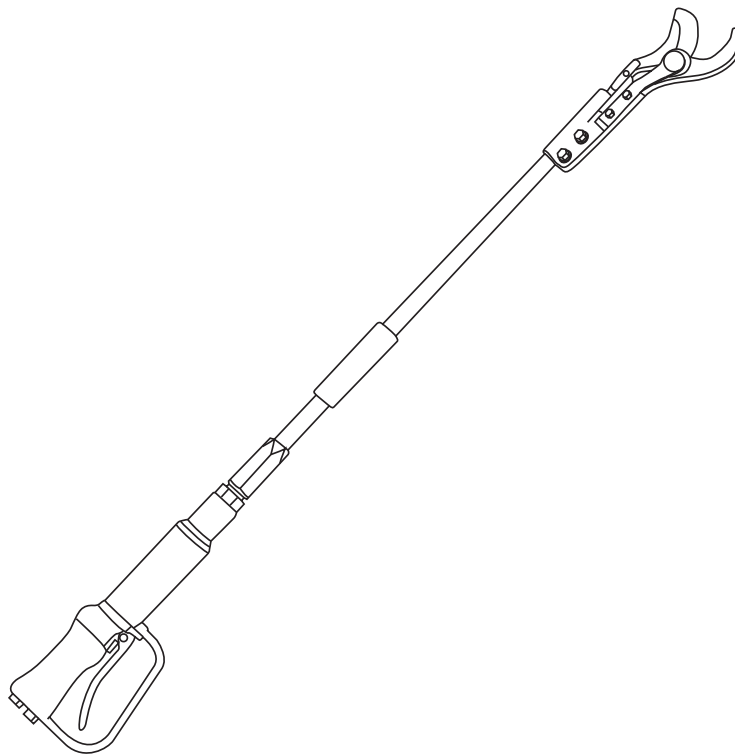

LHFS-210003 Pruner

Serial Code FFD



Read and understand all of the instructions and safety information in this manual before operating or servicing this tool.

Register this product at www.greenlee.com

Table of Contents

Safety	2
Purpose of this Manual	2
Other Publications	2
Important Safety Information	3-4
Maintenance	5-7
Troubleshooting	7-9
Disassembly	10-11
Inspection	11
Assembly	12-13
Illustration and Parts List	14-15
Closed-Center Conversion	16

Safety

Safety is essential in the use and maintenance of Greenlee tools and equipment. This service manual and any markings on the tool provide information for avoiding hazards and unsafe practices related to the use of this tool. Observe all of the safety information provided.

Purpose of this Manual

This manual is intended to familiarize personnel with the safe service procedures for the following Greenlee Utility tools:

LHFS-210003 Open-Center Hydraulic Pruner
Serial Code FFD

Keep this manual available to all personnel.

Replacement manuals are available upon request at no charge at www.greenlee.com.

Other Publications

Operation Manual: Publication 99930331

Specifications and Parts: Publication 99930366

SAE Standard J1273 (Hose and Hose Assemblies):
Publication 99930323

All specifications are nominal and may change as design improvements occur. Greenlee Textron Inc. shall not be liable for damages resulting from misapplication or misuse of its products.

KEEP THIS MANUAL

IMPORTANT SAFETY INFORMATION



SAFETY ALERT SYMBOL

This symbol is used to call your attention to hazards or unsafe practices which could result in an injury or property damage. The signal word, defined below, indicates the severity of the hazard. The message after the signal word provides information for preventing or avoiding the hazard.

⚠ DANGER

Immediate hazards which, if not avoided, WILL result in severe injury or death.

⚠ WARNING

Hazards which, if not avoided, COULD result in severe injury or death.

⚠ CAUTION

Hazards or unsafe practices which, if not avoided, MAY result in injury or property damage.



⚠ WARNING

Read and understand all of the instructions and safety information in this manual before operating or servicing this tool. Refer also to the following manuals, which are listed under "Other Publications":

- Operation Manual
- Specifications and Parts Manual

Failure to observe this warning could result in severe injury or death.



⚠ WARNING

Electrical shock hazard:
This is not an insulated tool.
Do not use near electrical lines.
Contact with live circuits could result in severe injury or death.

⚠ WARNING



Skin injection hazard:

- Do not use hands to check for leaks.
- Do not hold hose or couplers while the hydraulic system is pressurized.
- Depressurize the hydraulic system before servicing.

Oil under pressure easily punctures skin causing serious injury, gangrene, or death. If you are injured by escaping oil, seek medical attention immediately.



⚠ WARNING

Keep hands and fingers away from closing blades.

Failure to observe this warning could result in severe injury or death.

⚠ WARNING

- Inspect the cutter blade every operating day. Remove and destroy cutter blade if cracks, chips, or gouges are evident. A damaged blade can break and strike nearby personnel.
- Do not change accessories, inspect, adjust, or clean tool when it is connected to a power source. Accidental start-up can result in serious injury.
- Maintain a firm grip on tool, using both hands at all times. Serious injury can result if the operator does not control the tool.

Failure to observe these warnings could result in severe injury or death.

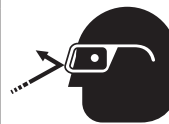

⚠ WARNING

Wear eye protection when operating or servicing this tool.

Failure to wear eye protection could result in serious eye injury from flying debris or hydraulic oil.

IMPORTANT SAFETY INFORMATION

⚠ WARNING

Do not exceed the following hydraulic power source maximums:

- Hydraulic flow: 22.7 l/min (6 gpm)
- Pressure relief: 138 bar (2000 psi)
- Back pressure: 13.8 bar (200 psi)

Failure to observe this warning could result in severe injury or death.

⚠ WARNING

Do not disconnect tool, hoses, or fittings while the power source is running or if the hydraulic fluid is hot. Hot hydraulic fluid can cause serious burns.

⚠ WARNING

Do not reverse hydraulic flow. Operation with hydraulic flow reversed can cause tool malfunction. Connect the pressure (supply) hose and tank (return) hose to the proper ports.

Failure to observe this warning could result in severe injury or death.

⚠ CAUTION

- Use this tool for the manufacturer's intended purpose only. Use other than that which is described in this manual can result in injury or property damage.
- Inspect hydraulic hoses and couplings every operating day. Repair or replace if leakage, cracking, wear, or damage is evident. Damaged hoses or couplings can fail resulting in injury or property damage.
- Make sure all bystanders are clear of the work area when handling, starting and operating the tool. Nearby personnel can be injured by flying or falling debris or by flying parts in the event of a tool malfunction.

Failure to observe these precautions may result in injury.

⚠ CAUTION

Hydraulic oil can cause skin irritation.

- Handle the tool and hoses with care to prevent skin contact with hydraulic oil.
- In case of accidental skin contact with hydraulic oil, wash the affected area immediately to remove the oil.

Failure to observe these precautions may result in injury.

IMPORTANT

Procedure for connecting or disconnecting hydraulic hoses, fittings, or components:

1. Move the flow lever on the hydraulic power source to the off position.
2. Stop the hydraulic power source.
3. Follow the sequence under "Hose Connections" in the Operation Manual to prevent pressure buildup. In case some pressure has built up, loosen hoses, fittings, or components slowly

IMPORTANT

Emergency stop/power failure procedure:

1. Release the trigger.
2. Shut off the hydraulic power source.

Note: Keep all decals clean and legible, and replace when necessary.

Maintenance

The service life of the tool will be maximized by proper care and maintenance. The maintenance schedule that follows is recommended.

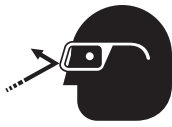
	<h3>⚠ WARNING</h3>
	<p>Wear eye protection when operating or servicing this tool.</p> <p>Failure to wear eye protection could result in serious eye injury from flying debris or hydraulic oil.</p>

<h3>⚠ WARNING</h3>
<ul style="list-style-type: none"> Do not change accessories, inspect, adjust, or clean tool when it is connected to a power source. Accidental start-up can result in serious injury. Inspect the blade every operating day. Remove and destroy the blade if cracks, chips, or gouges are evident. A damaged blade can break and strike nearby personnel. <p>Failure to observe these warnings could result in severe injury or death.</p>

<h3>⚠ CAUTION</h3>
<p>Inspect hydraulic hoses and couplings every operating day. Repair or replace if leakage, cracking, wear, or damage is evident. Damaged hoses or couplings can fail resulting in injury or property damage.</p> <p>Failure to observe this precaution may result in injury.</p>

Maintenance Schedule

Daily

- Wipe all tool surfaces clean.
- Inspect the cutter unit. Check for wear at the pivoting and sliding surfaces. Repair the blade with a very fine file and a pocket whetstone. **Remove and destroy any cutter blade with severe cracks, chips or gouges.**
- Lubricate the pivoting and sliding surfaces several times every operating day with 20W or 30W oil. Apply a heavy coating to these surfaces before storing.
- Several times a day the blade and hook must be dressed with a pocket whetstone. This keeps the cutting edge from rolling and chipping.
- Make sure the extension tube connector nut and the cutter mounting bracket bolts are tightened securely.

- Inspect hydraulic system hoses and fittings for signs of leaks, cracks, wear, or damage.
- To prevent contamination, always install dust caps over couplers when tool is disconnected.

Monthly

Perform a thorough inspection of the hydraulic hoses and fittings as described in publication 99930323, SAE J1273 (Hose and Hose Assemblies).

Lubrication

Lubricate the indicated pivoting and sliding surfaces several times every operating day with 20W or 30W oil. Apply a heavy coating to these surfaces before storing.

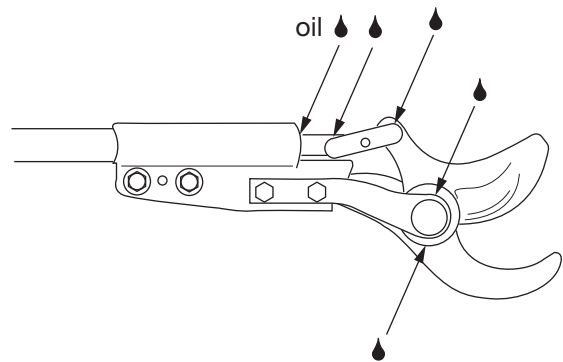

Lubrication

Blade and Hook Maintenance

<h3>⚠ WARNING</h3>
<p>Do not change accessories, inspect, adjust, or clean tool when it is connected to a power source. Accidental start-up can result in serious injury.</p>

Dressing the Cutter Blade and Hook

A buildup of metal, referred to as a wire edge, will form on the edge of a new blade as it seats across the face of the hook. This wire edge must be removed several times, until the blade seats itself to the hook.

Rough and dull edges may form on the cutter blade and the cutter hook from normal usage. Both components must be dressed with a pocket whetstone several times each operating day. This keeps the cutting edges sharp and prevents them from rolling and chipping.

- Stop the power source.
- Use the provided pocket whetstone (50423921) to remove the wire edge by rubbing the whetstone back and forth on the blade and hook until the surface irregularities are smooth and the blade edge is sharp.

Maintenance (cont'd)

Sharpening the Cutter Blade

When a blade has acquired deep nicks and gouges or has become too dull to be sharpened with a whetstone, remove the cutter blade and sharpen it with a fine metal-cutting file.

1. Disconnect the tool from the power source.
2. Remove the cutter blade from the tool. Refer to "Cutter Head" in the "Disassembly" section of this manual.
3. Sharpen the blade with a fine metal-cutting file.

*Note: When sharpening with a file, it is important to maintain the original shape and contour of the blade. An equal amount of material must be removed from all parts of the blade. **Do not** sharpen the blade to a thin, razor edge. This reduces the strength and shortens the service life of the blade. Do not overuse the file. It is not advisable to remove large amounts of metal from the blade.*

4. After the contoured side of the blade has been sharpened, turn it over so that the flat side is facing up. Dress the blade with a whetstone just enough to smooth away any nicks and irregular sharp edges that may have formed during sharpening of the contoured side of the blade.
5. Remove any nicks or rough edges on the hook with a pocket whetstone. The inner curve of the hook should have a beveled cutting edge. This can be achieved with the whetstone also. Failure to do this can ruin a new or sharpened blade.

Tension Adjustment

The tension adjustment should be checked after about one hour of use on a new cutter. A wearing-in process takes place during this time and the cutter pivot nut may need tightening.

The cutter hook and cutter blade must fit together snugly. If they are too tight, the cutter will not perform properly. If the fit is too loose, the tool will not cut cleanly, and damage to the tool may occur.

1. Disconnect the tool from the power source.
2. Refer to figure below. Disconnect the cutter blade (1) from the linkage that secures it to the extension rod end.
3. Remove the #10 x 1/4 inch socket head cap screw (2), #10 lock washer (3) and the lock (4).
4. Tighten or loosen the 3/8-24 cutter pivot nut (5) until some drag is felt when the blade (1) is opened or closed.
5. Install the lock (4) over the 3/8-24 cutter pivot nut (5). Secure the lock (4) with the #10 x 1/4 inch socket head cap screw (2) and the #10 lock washer (3).

Note: If the slot in the lock (4) does not align with the threaded hole in the cutter hook (6), turn the lock (4) over. This will allow the lock to be positioned so that the slot will line up with the threaded hole in the cutter hook, allowing the #10 x 1/4 inch socket head cap screw (2) to secure it in place.

6. Reconnect the linkage to the cutter blade (1) and extension rod end.

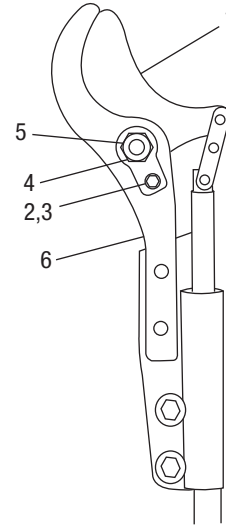

Tension Adjustment

Closure Adjustment

⚠ WARNING

Do not change accessories, inspect, adjust, or clean tool when it is connected to a power source. Accidental start-up can result in serious injury.

Proper closing adjustment of the cutter is set at the factory, and should not be re-set until repeated sharpening of the blade or installation of a new blade requires it. When closed, the blade should cover about 1/3 of the surface of the cutter hook.

If the blade is improperly adjusted, the blade closure must be re-adjusted while the blade is in the fully closed mode.

Maintenance (cont'd)

1. Refer to the figure below. While depressing the trigger, disconnect the tool from the hydraulic power source. This will leave the blade (1) in the correct position (fully-closed) for adjusting proper blade closure.
2. Remove the two 1/4-28 hex lock nuts (2) and 1/4 x 7/8" hex head cap screws (3) which secure the cutter and mounting assembly (4) onto the extension tube (5). Insert one of the cap screws into the blind hole in the cutter mounting bracket (4) and tighten until the cutter mounting bracket is loose on the extension tube (5).
3. Move the entire cutter and mounting assembly (4) up or down on the extension tube (5) until proper blade closure is attained (approximately 1/3 of surface of hook should be covered by the blade). Remove the cap screw from the cutter mounting bracket (4).
4. Reinstall and tighten the two 1/4-28 hex lock nuts (2) and 1/4 x 7/8" hex head cap screws (3) to secure the cutter mounting bracket (4) to the extension tube (5).
5. Connect the tool to the hydraulic power source and actuate the tool several times. Blade action should be smooth and uniform from the fully-open position to the fully-closed position (approximately 1/3 of surface of hook should be covered by the blade). There should be no excessive play in the cutter unit linkage.

Repeat the above procedure until the blade closure is correct.

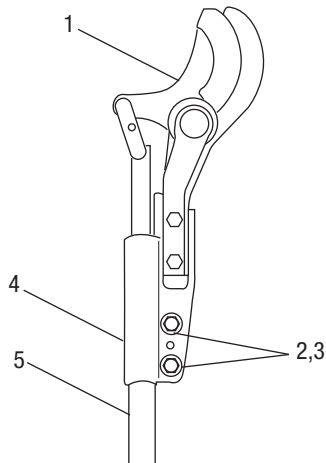

Adjusting Blade Closure

Troubleshooting

Before You Begin

1. Tool must be connected to the correct power source system. Refer to the Specifications and Parts manual for the type of hydraulic system required. Verify the power source hydraulic system.
2. Verify that the pressure and return hoses are connected properly to the tool and power source ports.
3. Power source reservoir must be filled to FULL mark with hydraulic fluid.
4. Start the power source. All power source shut-off devices must be engaged or opened (clutch-engaged, separate ON/OFF valves open, etc.).
5. After verifying all of the above, check the tool to see if it operates.

If the tool does not operate, it will be necessary to pinpoint the tool, hose, or power source as the problem area. The following steps will help to determine the problem area.

Determine the Problem Area

1. Check the power source and pressure if the proper gauges and tools are available. If these items are not available, proceed to the next step.
2. Stop the power source.
3. Disconnect the tool from the hoses and power source.
4. Connect a known working tool to the hoses and power source. Refer to the tool's operator's manual for correct hookup procedure. Start the power source.
 - If the known working tool operates, the problem is in the disconnected tool. Refer to the Troubleshooting charts in this manual.
 - If the known working tool does not operate, the problem is likely to be in the hoses or the power source. Proceed to next step.
5. Stop the power source.
6. Disconnect the existing hoses from the known working tool and power source.
7. Connect a different set of hoses to the known operating tool and power source. Start the power source.
 - If the known working tool operates with the different set of hoses, the problem is in the disconnected hoses.
 - If the known working tool does not operate, the problem is in the power source. Refer to your power source operator's manual for troubleshooting.

Troubleshooting (cont'd)

Problem	Probable Cause	Probable Remedy
Tool inoperative.	Tool connected to improper power source hydraulic system.	Verify that the power source meets the specifications. Refer to the Specifications and Parts manual.
	No hydraulic fluid in system or fluid level low.	Check fluid level. Fill to FULL mark. Check system for leaks.
	Incorrect fluid viscosity.	Use fluid viscosity recommended. Refer to the Specifications and Parts manual.
	Tool components loose.	Tighten component hardware.
	Dirt, contaminants, etc., in tool components.	Disassemble tool and clean components.
	Tool components worn or damaged.	Disassemble tool. Replace worn or damaged components.
Tool operates erratically.	Hydraulic fluid cold.	Viscosity of oil may be too high at start of tool operation. Allow oil to warm to operating temperature. Actuating tool intermittently will reduce time required to warm oil to an efficient operating temperature.
	Air in hydraulic system.	Check pump suction line for damage or loose clamps. Tighten clamps or replace components if necessary. Fill reservoir.
	Tool components sticking or binding.	Check for dirt or gummy deposits. Clean components. Check for worn or damaged components. Replace components.
	Dirt, contaminants, etc., in tool components.	Disassemble tool and clean components.
Tool operates slowly.	Power source components not adjusted correctly.	Refer to power source operator's manual for recommended speed, flow, and pressure settings.
	Hydraulic fluid cold.	Viscosity of oil may be too high at start of tool operation. Allow oil to warm to operating temperature. Actuating tool intermittently will reduce time required to warm oil to an efficient operating temperature.
	Hydraulic fluid level low.	Check fluid level. Fill to FULL mark. Check system for leaks.
	Hydraulic fluid viscosity too heavy.	Use fluid viscosity recommended. Refer to the Specifications and Parts manual.
	Tool components loose.	Tighten component hardware.
	Dirt, contaminants, etc., in tool components.	Disassemble tool and clean components.
	Tool components worn or damaged.	Disassemble tool. Replace worn or damaged components.
Tool leaks hydraulic fluid.	Tool components loose.	Tighten component hardware.
	Tool components worn or damaged.	Disassemble tool. Replace worn or damaged components.

Troubleshooting (cont'd)

Problem	Probable Cause	Probable Remedy
Tool feels hot.	Hydraulic fluid level low.	Check fluid level. Fill to FULL mark. Check system for leaks.
	Hydraulic fluid viscosity exceeds specifications.	Use fluid viscosity recommended. Refer to the Specifications and Parts manual.
	Hydraulic fluid dirty.	Drain reservoir, flush and fill with clean fluid. Change filter.
	Tool control valve stuck in partial power-on position	Free spool so it returns to neutral position.
	Power source components not adjusted correctly.	Refer to power source operator's manual for recommended speed, flow, and pressure settings.
	Dirt, contaminants, etc., in tool components.	Disassemble tool and clean components.
	Worn or damaged O-rings or gaskets.	Replace worn or damaged O-rings or gaskets.
	Tool components worn or damaged.	Disassemble tool. Replace worn or damaged components.
Tool control valve sticks or works hard.	Check for dirt or gummy deposits.	Clean components.
	Misalignment or binding of control linkage.	Correct alignment. Lubricate linkage joints. Replace damaged components.
	Valve components worn or damaged.	Disassemble valve and replace worn or damaged components.
Tool operates backwards.	Hydraulic flow reversed to tool.	Reverse flow to tool. Check for valve in system that has reversed flow. Check hoses for proper flow.
	Hydraulic pressure and return lines connected to opposite tool ports.	Disconnect hoses. Reverse couplers. Reconnect hoses to proper tool ports.
	Tool components assembled incorrectly.	Disassemble tool. Reassemble correctly.
Tool operates, but blade does not cut.	Cutter blade loose.	Tighten cutter blade nut and bolt securely. Refer to "Tension Adjustment" in the "Maintenance" section of this manual.
	Cutter blade not closing properly.	Readjust blade closure. Refer to "Closure Adjustment" in the "Maintenance" section of this manual.
	Cutter blade dull.	Remove blade and sharpen, or install a sharp, new blade.
Extension assembly loose.	Loose extension connector nut.	Tighten extension connector nut.

Disassembly

Complete disassembly of the tool is not recommended. If a complete overhaul is necessary, return the tool to your nearest Greenlee Utility Authorized Service Center.

	<h3>⚠ WARNING</h3>
	<p>Skin injection hazard:</p> <ul style="list-style-type: none"> • Do not use hands to check for leaks. • Do not hold hose or couplers while the hydraulic system is pressurized. • Depressurize the hydraulic system before servicing. <p>Oil under pressure easily punctures skin causing serious injury, gangrene, or death. If you are injured by escaping oil, seek medical attention immediately.</p>

<h3>⚠ WARNING</h3>
<p>Do not disconnect tool, hoses, or fittings while the power source is running or if the hydraulic fluid is hot. Hot hydraulic fluid can cause serious burns.</p>

<h3>IMPORTANT</h3>
<p>Procedure for connecting or disconnecting hydraulic hoses, fittings, or components:</p> <ol style="list-style-type: none"> 1. Move the flow lever on the hydraulic power source to the off position. 2. Stop the hydraulic power source. 3. Follow the sequence under “Hose Connections” in the Operation Manual to prevent pressure buildup. In case some pressure has built up, loosen hoses, fittings, or components slowly

The disassembly procedure is divided into sections of the tool. Complete disassembly of tool is seldom necessary. Disassemble only the area(s) necessary to correct problem. See Parts illustrations for identification of parts as they are removed.

Disassembly should be done on a flat, clean surface. Some parts may fall free during disassembly. To prevent part loss or damage, keep the tool as close to working surface as possible.

Inspect all parts as they are disassembled and mating parts in tool that are not removed for signs of damage, wear, cracks, etc. Replace any parts which appear to be damaged.

When removing O-rings which must slide over sharp surfaces, be careful not to damage the O-rings. Use a rolling motion, and apply hydraulic fluid to ease removal of O-rings if necessary.

Cutter Head

1. Remove the #10-32 x 5/18 inch hex head machine screw (23), #10 lockwasher (24), both link arms (25, 28), two lock pins (27) and the spacer (26).
2. Remove the two 1/4-28 x 7/8 inch hex head cap screws (17) and 1/4-28 hex lock nuts (19) which secure the cutter and mounting assembly (18) onto the extension tube (10).
3. Insert one of the 1/4-28 x 7/8 inch hex head cap screws (17) into the blind threaded hole on the blade side of cutter mounting bracket (18). Tighten bolt until cutter mounting bracket is loose on the extension tube (10).
4. Remove the cutter and mounting assembly from the extension tube (10).
5. Remove the #10-32 x 1/4 inch socket head cap screw (32). The #10 lock washer (24) and the lock (31).
6. Remove the 3/8-24 hex nut (33) and cutter bolt (22). Remove the cutter blade (29) and thin brass washer (67).
7. Remove the two 1/4-28 x 7/8 inch hex head cap screws (17) and 1/4 inch lock washers (20) which secure the cutter brace (21) and cutter hook (30) to the cutter mounting bracket (18). Remove the cutter brace (21) and cutter hook (30).

Outer Extension Tube and Inner Extension Rod

1. Loosen the extension connector nut (15) and slide it away from the actuator assembly. Remove the outer extension tube (10) by sliding it over the inner extension rod and extension rod end (6, 7).
2. If necessary, remove the lower collet ring (8), clamp ring (9), clamp collet (12), upper collet ring (13), extension connector nut (15) and hand grip (11) from the outer extension (10).
3. Remove the inner extension rod (6) from the shaft of the piston (2) using two 1/2 inch open-end wrenches on the wrench flats milled in the swivel piston shaft.
4. If necessary, remove the extension rod end (7) from the inner extension rod (6).

Disassembly (cont'd)

Ram and Piston Actuator

1. Remove jam nut (14) from upper end actuator (59).
2. Use a strap wrench to unscrew cylinder (53) from upper end (59). The piston and rod assembly (63) will remain in cylinder (53) when unscrewing and removing from upper end (59).
3. Remove rod seal (54), seal (47), bushing (57), piston seal (55) and seal retainer (56) from upper end (59).
4. Remove piston and rod assembly (63) with seals (52, 50, 51, 60, 61) from cylinder (53).
5. Remove the seals (60, 61) from piston and rod assembly (63).
6. Remove the 3/4 inch internal retaining ring (52) from inside of piston and rod assembly (63). Remove seal retainer (50) and bypass seal (51).
7. Remove O-ring (47) from handle (75). Remove 3/4 inch internal retaining ring (52) which secures return tube assembly (49) into the handle (75). Remove return tube assembly. Remove O-ring (48) from return tube assembly (49).
8. Remove the #10 x 1/4-inch round slotted head screws (66) and internal tooth lock washers (65). Remove trigger guard (64).
9. Remove the 5/32 inch external retaining rings (36) and slide trigger pivot pin (35) out of handle (75). Remove trigger (34).
10. Remove valve cap (43) from valve handle (75) opposite trigger side. Also remove spring (42). Remove valve stem guide (37); valve stem (38) and spool (40) from trigger side. Remove O-ring (39) from spool (40). Also remove O-ring (41) from valve handle (75).

Inspection

1. Cutter Blade (29): Cutting surface must be smooth and free of grooves, nicks, or gouges. If blade has minor grooves, nicks, or gouges, remove them and sharpen blade with a file or the pocket whetstone provided with tool. If blade has severe damage, replace the blade. Both holes in blade are pivot holes. If either hole is out-of-round, replace blade.
2. Cutter Hook (30): The surface of the cutter hook which mates with the cutter blade (29) must be smooth and free of nicks or gouges. If hook has minor blemishes, remove them with a file. The inner radius of hook's cutting surface must be beveled slightly with a pocket whetstone provided with tool.
3. Valve spool (40): All surfaces must be smooth and free of grooves, nicks, or scratches. If it has grooves, nicks, or scratches, replace the spool.
4. Piston and Rod Assembly (63): All surfaces must be smooth and free of grooves, nicks, or scratches. If either component has grooves, nicks, or scratches, replace the component.
5. Cylinder (53): All inner surfaces must be smooth and free of grooves, nicks, or scratches. If either component has severe grooves, nicks, or scratches, replace the component.
6. Inner Extension Assembly (6): All components must be straight and free of damage. Replace if bent or damaged.
7. O-Rings and Seals: Always replace O-rings and seals in components that have been disassembled with new O-rings and seals during assembly. A packing kit is available that includes all O-rings and seals.

Assembly

When assembling parts, refer to Parts illustrations for correct orientation and placement of parts.

Clean all parts with solvent (take care to protect eyes), then dry thoroughly. Do not expose O-rings or other packing components to solvent for long periods of time.

Inspect all parts as they are assembled for signs of damage, wear, cracks, etc. Do not install any parts which appear to be damaged.

Apply hydraulic fluid or O-ring lubricant to all O-rings and all metal surfaces which O-rings must slide over. When installing an O-ring over a sharp edge, use a rolling action to avoid damage to O-ring.

Wherever assembled parts cause metal-to-metal contact, coat the surfaces with hydraulic fluid or O-ring lubricant.

Handle and Valve

1. Install O-ring (41), spool (40), spring (42), cap (43), to upper end of insulated valve body handle (75).
2. Install O-ring (39), stem (38) and stem retainer (37) on lower end of valve body handle (75).
3. Position trigger (34) on valve handle (75), aligning holes in each component. Install trigger pivot pin (35) and secure in place with two 5/32 external retaining rings (36).
4. Position trigger guard (64) on handle (75) and secure with 1/4-inch round slotted head cap screws (66) and internal tooth lock washers (65).
5. Install O-ring (47) onto handle (75).
6. Install O-ring (48) on return tube assembly (49). Install return tube assembly in handle and secure in place with 3/4-inch internal retaining ring (52).
7. Install rod seal support (54), bushing (57), O-ring (55) and seal (56) and O-ring (47) on upper end (59).
8. Clamp upper end (59) in a vise and thread cylinder (53) onto upper end (59). Tighten with a strap wrench.
9. Install piston seals (61) and back-up washers (60) on piston and rod assembly (63).
10. Install bypass seal (51), seal retainer (50) in bottom end of piston and rod assembly (63) and secure into place with 3/4" internal retaining ring (52).
11. Slide piston and rod assembly (63) in cylinder and upper end.
12. Thread handle assembly (75) onto cylinder (53). Thread nut (14) onto upper end (59).

Outer Extension Tube and Inner Pull Rod

1. Apply Loctite 242-05 (F015774) or equal, onto both threaded ends of the inner extension rod assembly (6). Follow the manufacturer's instruction for curing.
2. Thread the extension rod end (7) onto the inner extension rod (6). Thread the swivel assembly (1) onto the lower end of the inner extension rod (6). Thread the other end of swivel (1) into the shaft of piston rod (63). Tighten everything securely, using two 1/2 inch open-end wrenches on the wrench flats milled in both components.
3. If removed, install the hand grip (11) onto the outer extension tube (10). The nearest end of the hand grip (11) must be 5 inches from the end of the outer extension tube (10).
4. Slide the extension connector nut (16), tapered end first, onto the outer extension tube (10). Install the upper collet ring (13), beveled end first, and clamp collet (12) onto the outer extension tube (10). Install the clamp ring (9) to secure the components to the tube. Slip the lower collet ring (8) onto the end of the outer extension tube (10).
5. Apply a liberal amount of grease (F015437) onto the extension rod end (7) and inner extension rod (6). Slide the outer extension tube (10) over the rod and rod end (6, 7). Thread the extension connector nut (15) onto the upper end (59). Tighten securely.

Cutter and Mounting Unit

1. Mount the cutter brace (2) and cutter hook (30) onto the cutter mounting bracket (18). Loosely thread the two 1/4-28 x 7/8 inch hex head cap screws (17) and 1/4 inch lock washers (20). The cap screws (17) must be installed through the brace (21), then the mounting bracket (18), and finally into the threaded holes in the hook (30).
2. Install the cutter blade (29) and brass washer (67) between the brace (2) and hook (30). Align the holes of all these components and insert the cutter bolt (22). Thread the 3/8-24 hex nut (33) onto the cutter bolt (22). Tighten the 3/8-24 hex nut (33) until some drag is felt when the blade is opened or closed. The cutter blade (29) should pivot around the cutter bolt (22) with slight tension.

Note: The cutter hook (30) and cutter blade (29) must fit together snugly. If they are too tight, the cutter will not perform properly. If the fit is too loose, the tool will not cut cleanly, and damage to the tool may occur. Wood may jam in-between the hook and cutter blade, springing them apart and permanently bending one or the other.

Assembly (cont'd)

3. Install the lock (31) onto the cutter hook (30) and secure with the #10 x 1/4 inch socket head cap screw (32) and #10 lock washer (24).

Note: If the slot in the lock (31) does not align with the threaded hole in the cutter hook (30), turn the lock over. This will allow the lock to be positioned so that the slot will line up with the threaded hole in the cutter hook, allowing the #10 x 1/4 inch socket head cap screw to secure it in place.

4. Securely tighten the two 1/4 x 7/8 inch hex head cap screws (17) that secure the brace (21) and hook (30) to the mounting bracket (18).
5. Slide the cutter and mounting assembly onto the extension tube (10).
6. Connect the cutter hook (29) and rod end (7) together with the link arm (25, 28) and lock pins (27). Insert the spacer (26) between the two link arms (25, 28). Secure the link arms (25, 28) with the #10-32 x 5/8 inch hex head machine screw (23) and #10 lock washer (24). Tighten securely.
7. Move the blade (29) and the connecting linkage to the fully-closed position. When the blade is fully closed, it should cover about 1/3 of the surface of the hook (30).
8. When proper closure is attained, install the two 1/4-28 x 7/8 inch hex head cap screws (17) and 1/4-28 hex lock nuts (19) which secure the cutter and mounting assembly to the extension tube (10). Tighten securely.

Illustration

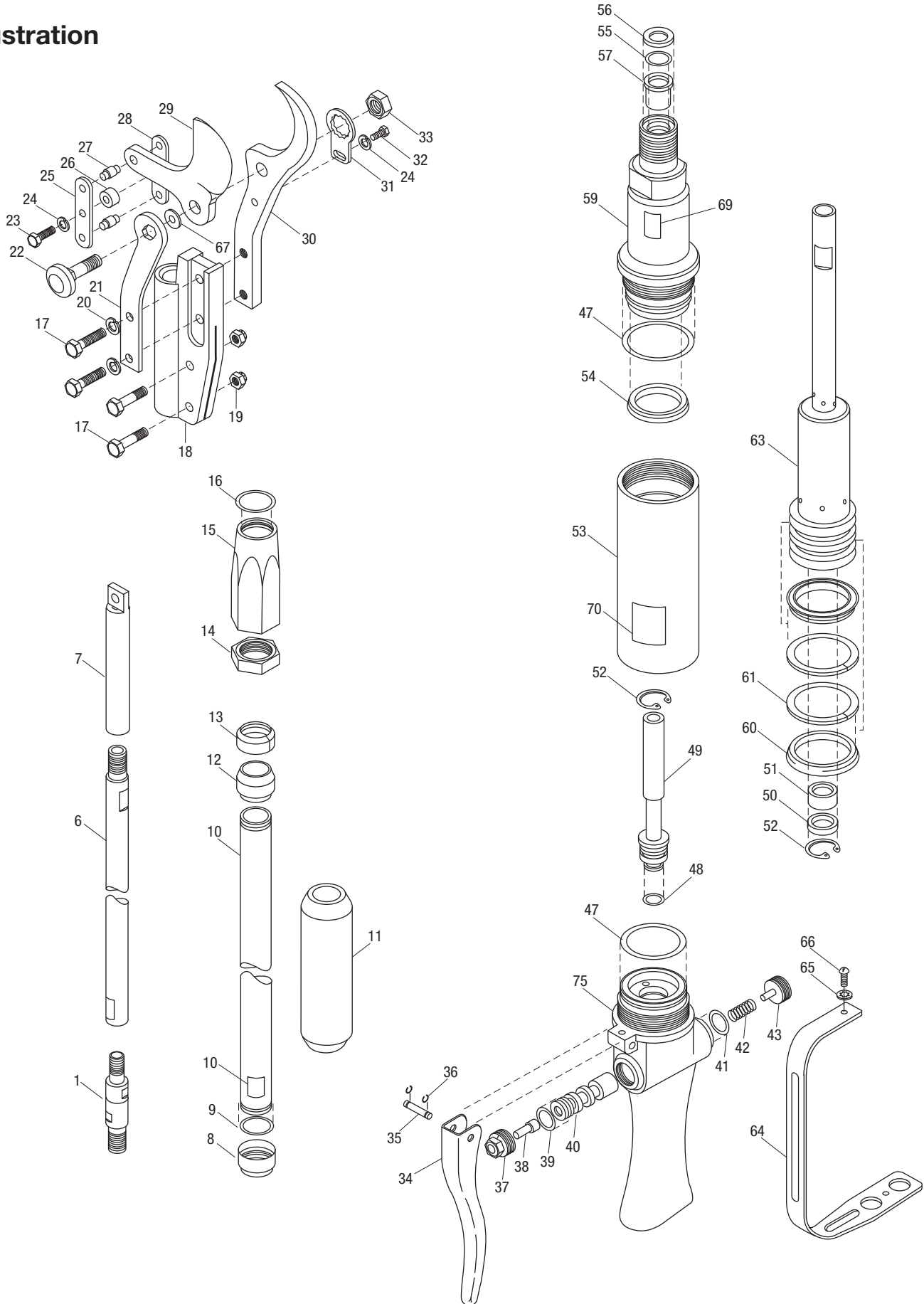

Parts List

Key	UPC No. 78-3310-	Part No.	Description	Qty	Key	UPC No. 78-3310-	Part No.	Description	Qty
1	48850	50488503	Swivel Assembly, Inner	1	39*			O-ring, .437 x .562 x .062-70	1
6	42526	50425261	Extension Rod, 36"	1	40	42536	50425361	Valve Plunger	1
7	42553	50425531	Extension Rod End	1	41*			O-ring.....	2
8	42520	50425202	Ring, Lower Collet	1	42	42865	50428651	Spring, Valve Plunger.....	1
9	42860	50428600	Ring, Clamp	1	43	42546	50425461	Cap, Valve.....	1
10	42516	50425162	Extension Tube, 36"	1	47*			O-ring, .625 x 1.75 x .062	2
11	42023	50420234	Grip, Rubber	1	48*			O-ring, .375 x .500 x .062-70	1
12	42521	50425212	Clamp, Collet	1	49	42548	50425480	Tube, Return	1
13	42522	50425222	Ring, Upper Collet	1	50	42544	50425441	Seal Retainer.....	1
14	42551	50425511	Nut, Jam	1	51*			Seal, Bypass	1
15	42550	50425502	Nut, Extension Connector.....	1	52	41648	50416480	Retaining Ring, .750.....	2
16*			O-ring, .812 x 1.00 x .093-70	1	53	42540	50425402	Cylinder.....	1
17	42059	50420592	Screw, Cap, 1/4-28 x .875, Hex Head	4	54*			Seal, Piston Rod	1
18	42552	50425521	Bracket, Mounting	1	55	41335	50413352	O-ring, .562 x .750 x .093-70	1
19	41369	50413691	Nut, Hex, 1/4-28, Lock.....	2	56	42511	50425112	Seal, Retainer.....	1
20	42808	50428080	Washer, Lock, 1/4	2	57	42506	50425062	Bushing	1
21	42530	50425302	Brace, Cutter.....	1	59	42351	50423512	Actuator, Upper End	1
22	42512	50425122	Bolt, Cutter.....	1	60*			Seal, Piston	2
23	42782	50427820	Screw, Machine, #10-32 x .625, Hex Head	1	61*			Backup Ring	2
24	42807	50428071	Washer, Lock, #10	2	63	42352	50423522	Piston/Rod	1
25	42532	50425322	Arm, Link (Unthreaded).....	1	64	42577	50425770	Trigger Guard	1
26	42533	50425332	Spacer.....	1	65	42812	50428121	Washer, Lock, #10	2
27	42519	50425191	Pin, Link	2	66	41677	50416770	Screw, Machine, #10-32 x .375, Round Head.....	2
28	42531	50425312	Arm, Link (Threaded).....	1	67	40001	50400015	Washer, Flat, .484 x 1.500 x .010, Brass	1
29	42555	50425551	Blade.....	1	68		52000942	Plug.....	2
30	42554	50425541	Hook	1	69	43676	128067	Decal.....	1
31	42695	50426951	Lock	1	70	41114	50411144	Decal.....	1
32	42785	50427851	Screw, Cap, #10-32 x .250, Socket Head	1	71	48243	50482432	Decal.....	1
33	41617	50416171	Nut, Hex, 3/8-24.....	1	72		52001218	Decal.....	1
34	42576	50425760	Trigger	1	73		52001220	Tag, Caution.....	1
35	42547	50425471	Pivot, Trigger.....	1	74		52001227	Ty, Plastic	1
36	42827	50428270	Retaining Ring.....	2	75		50426151	Handle.....	1
37	42429	50424291	Guide, Valve Stem	1					
38	42545	50425451	Stem, Valve.....	1					
Repair Kit									
	*	42374	50423741	Packing Kit (includes items marked with an asterisk).....	1				

Closed-Center Conversion for LHFS Pruners

Key	Part No.	Description	Qty
Remove:			
49	50425480	Tube, Return.....	1
48*		O-ring .375 x .500 x .062-70	1
51*		Seal, Bypass	1
50	50425441	Seal Retainer.....	1
52	50416480	Retaining Ring, .750.....	2
Add:			
1	50425490	Tube, Return.....	1
2	L080003	O-ring	1
3	50427450	O-ring	1
4	50425421	Seal Body.....	1
5	50413313	O-ring	1
52	50416480	Retaining Ring, .750.....	2

