

# SERVICE MANUAL

*Fairmont*<sup>®</sup>

CE

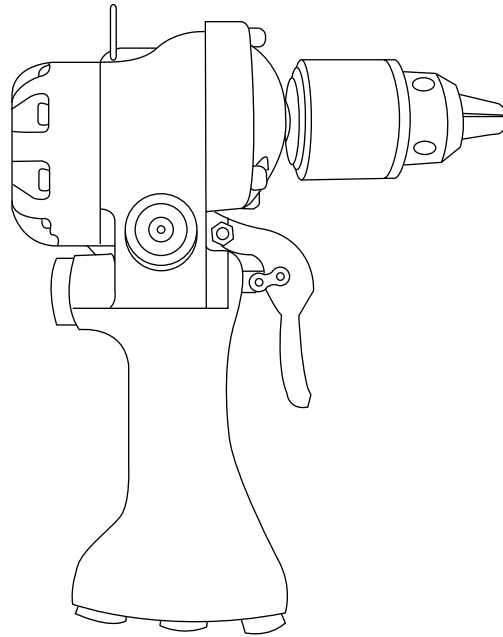

## **H6400, H6400C1 & VSD6400 REVERSIBLE DRILLS**



**Read and understand** all of the instructions and safety information in this manual before operating or servicing this tool.

## Table of Contents

Safety .....	2
Purpose .....	2
Other Publications .....	2
Important Safety Information .....	3-4
Disassembly .....	5-7
Inspection .....	8
Assembly .....	8-11
Illustrations and Parts Lists .....	12-15

## Purpose

This manual is intended to familiarize all personnel with the safe operation and maintenance procedures for the following Fairmont tools:

H6400C	(42260)	Serial Code FJL
H6400C1	(42661)	Serial Code FAB
VSD6400	(49755)	Serial Code GAY

Keep this manual available to all personnel.

Replacement manuals are available upon request at no charge.

 and **Fairmont®** are registered trademarks of Greenlee Textron.

Loctite® is a registered trademark of Loctite Corporation.

## Safety

Safety is essential in the use and maintenance of Fairmont tools and equipment. This instruction manual and any markings on the tool provide information for avoiding hazards and unsafe practices related to the use of this tool. Observe all of the safety information provided.

## Other Publications

Operation Manual:

Publication 999 3859.6

Specifications and Parts Manual:

Publication 999 3860.0

SAE Standard J1273 (Hose and Hose Assemblies):

Publication 999 3032.3

**KEEP THIS MANUAL**

**IMPORTANT SAFETY INFORMATION**



**SAFETY  
ALERT  
SYMBOL**

This symbol is used to call your attention to hazards or unsafe practices which could result in an injury or property damage. The signal word, defined below, indicates the severity of the hazard. The message after the signal word provides information for preventing or avoiding the hazard.

**⚠ DANGER**

Immediate hazards which, if not avoided, **WILL** result in severe injury or death.

**⚠ WARNING**

Hazards which, if not avoided, **COULD** result in severe injury or death.

**⚠ CAUTION**

Hazards or unsafe practices which, if not avoided, **MAY** result in injury or property damage.

**⚠ WARNING**



Skin injection hazard:  
Oil under pressure easily punctures skin causing serious injury, gangrene or death. If you are injured by escaping oil, seek medical attention immediately.

- Do not use fingers or hands to check for leaks.
- Do not hold hose or couplers while the hydraulic system is pressurized.
- Depressurize the hydraulic system before servicing.

**⚠ WARNING**

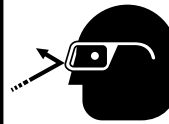

Wear eye protection when operating or servicing this tool.

Failure to wear eye protection can result in serious eye injury from flying debris or hydraulic oil.

**⚠ WARNING**

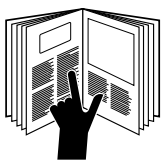

Read and understand all of the instructions and safety information in this manual before operating or servicing this tool. Refer also to the following manuals, which are listed under Other Publications:

- Operation Manual
- Specifications and Parts Manual

Failure to observe this warning can result in severe injury or death.

**IMPORTANT SAFETY INFORMATION**

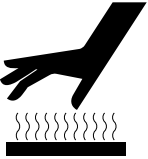
	<b>⚠ WARNING</b>
	<p>Tool, accessory, and other components may be hot during and after operation. Allow to cool before handling, or handle with heat-resistant gloves.</p> <p>Failure to observe this warning could result in severe injury.</p>

<b>⚠ WARNING</b>
<p>Do not reverse hydraulic flow. Operation with hydraulic flow reversed can cause tool malfunction. Connect the pressure (supply) hose and tank (return) hose to the proper tool ports.</p> <p>Failure to observe this warning can result in severe injury or death.</p>

<b>⚠ WARNING</b>
<p>Do not exceed the maximum hydraulic flow, pressure relief or back pressure listed in the Specifications and Parts manual.</p> <p>Failure to observe this warning can result in severe injury or death.</p>

<b>⚠ CAUTION</b>
<p>Hydraulic oil can cause skin irritation.</p> <ul style="list-style-type: none"> <li>• Handle the tool and hoses with care to prevent skin contact with hydraulic oil.</li> <li>• In case of accidental skin contact with hydraulic oil, wash the affected area immediately to remove the oil.</li> </ul> <p>Failure to observe these precautions can result in injury.</p>

<b>⚠ WARNING</b>
<p>Do not disconnect tool, hoses or fittings while the power source is running or if the hydraulic fluid is hot. Hot hydraulic fluid can cause serious burns.</p>

*Notes: Keep all decals clean and legible. Replace when necessary.*

*When disposing of any components (hydraulic hoses, hydraulic fluid, worn parts, etc.), do so in accordance with federal, state and local laws or ordinances.*

## Disassembly (H6400C & H6400C1)

Complete disassembly of the tool is not recommended. If a complete overhaul is necessary, return the tool to your nearest authorized Fairmont distributor or to Fairmont.

The disassembly procedure is divided into sections of the tool. Disassemble only the section(s) necessary to complete the repair.

Disassemble the tool on a flat, clean surface. Take care not to lose or damage any parts that may fall free during disassembly.

### Chuck

1. Secure the tool case in a vise.
2. From opposite sides of the tool, drive a pair of wedges between the chuck and case. See illustration.

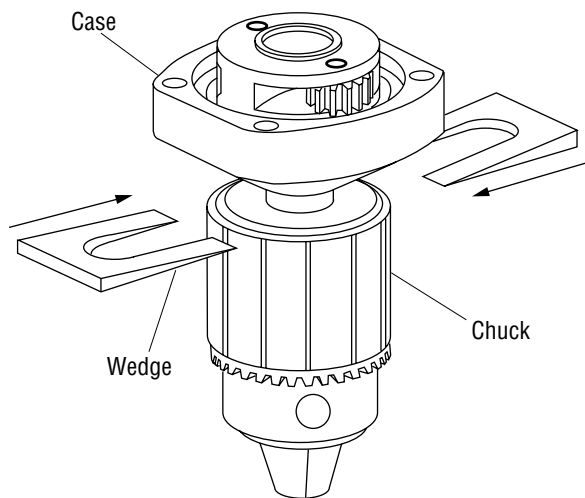

### Whip Hoses (H6400C1 only)

1. Remove tank hose (54) and O-ring (55).
2. Remove pressure hose (59) and O-ring (60).

### Case Components

1. *H6400C1 only:* Remove the auxiliary handle (63).
2. Scribe a line across the case (47 or 47A) and handle (1) to align parts correctly during assembly.
3. Remove four cap screws (50). Remove case from handle. Remove gasket (49). If necessary, press bearing (48) out of case.
4. Remove spindle assembly (40) from handle (1). If necessary, remove dowels (43) and gears (42).
5. Remove ring gear (2) and dowel pin (3) from handle (1).

### Motor

1. Scribe a line across the motor cap (6) and handle (1) to align parts correctly during assembly.
2. Remove eight cap screws (19) and remove motor cap from handle. Remove gasket (18) and dowels (17).
3. Remove idler shaft (15) and gear (12) from handle. Remove gear from idler shaft. Remove drive pin (16) from idler shaft.
4. Remove retaining ring (14), gear (12), and Woodruff key (13) from the drive shaft. Remove drive shaft (11) from handle.
5. Carefully remove the inner race (10) and eighteen steel balls (9) from the handle.
6. Use an O-ring tool to remove O-ring (4).

### Trigger, Control Spool and Super Spool Sleeve

1. Remove the cap screw (30) from the back end of the control spool (28).
2. Remove two nuts (39), machine screws (35, 36), and links (34) from the trigger assembly.
3. Remove nut (39), screw (38), and trigger (37) from the control spool (28).
4. Remove the washer (33) and spring (32) from the control spool (28). Slide the control spool out of the sleeve (25).
5. Remove the retaining ring (31) from the sleeve (25). Slide the sleeve out toward the back of the handle.
6. Remove the O-ring (29) from the control spool (28). Remove the O-rings (25A, 26, 27) from the sleeve (25).
7. Remove the O-ring (24) from the handle.

### Directional Spool

1. Remove the cap screws (23) and buttons (22) from the directional spool (20).
2. Slide the directional spool partially out of the handle to expose either O-ring (21). Remove the exposed O-ring. Remove the spool by pushing it back through the handle. Remove the other O-ring.

*Note: Attempting to force the directional spool through the bore against the O-ring will damage the O-ring and could allow particles of O-ring to get into the motor.*

## Disassembly (VSD6400)

Complete disassembly of the tool is not recommended. If a complete overhaul is necessary, return the tool to your nearest authorized Fairmont distributor or to Fairmont.

The disassembly procedure is divided into sections of the tool. Disassemble only the section(s) necessary to complete the repair.

Disassemble the tool on a flat, clean surface. Take care not to lose or damage any parts that may fall free during disassembly.

### Chuck

1. Secure the tool case in a vise.
2. From opposite sides of the tool, drive a pair of wedges between the chuck and case. See illustration.

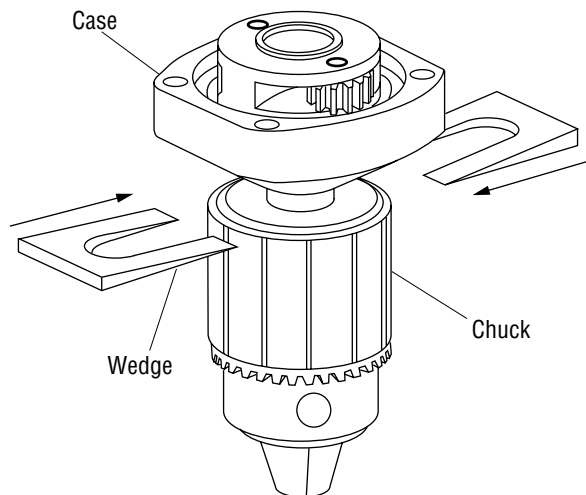

### Case Components

1. Remove the auxiliary handle (59).
2. Scribe a line across the case (60) and handle (1) to align parts correctly during assembly.
3. Remove four cap screws (52). Remove case from handle. Remove gasket (58). If necessary, press bearing (61) out of case.
4. Remove spindle assembly (54) from handle (1). If necessary, remove dowels (57) and gears (55).
5. Remove ring gear (4) and dowel pin (5) from handle (1).

### Motor

1. Scribe a line across the motor cap (47) and handle (1) to align parts correctly during assembly.
2. Remove eight cap screws (49) and remove motor cap from handle. Remove gasket (46) and dowels (45).
3. Remove idler shaft (43) and gear (40) from handle. Remove gear from idler shaft. Remove drive pin (44) from idler shaft.
4. Remove retaining ring (42), gear (40), and Woodruff key (39) from the drive shaft. Remove drive shaft (53) from handle.
5. Carefully remove the inner race (37) and eighteen steel balls (36) from the handle.
6. Use an O-ring tool to remove O-ring (2).

### Trigger, Control Spool and Super Spool Sleeve

1. Remove 3/4-inch internal retaining ring (25) and cap (24) from Super Spool™ sleeve (19). Remove compression spring (29) from end of control spool (26).
2. Remove connecting link (33) from trigger (32) and control spool (26). Remove one #10 x 1-1/4-inch round head machine screw (34) and hex elastic nut (35) from trigger (32). Remove trigger.
3. Remove 5/8-inch internal retaining ring (31) and washer (30). Remove control spool (26) from Super Spool™ sleeve (19). Remove O-ring (27) from control spool (26). If necessary, remove #6 x 1/4-inch pan head machine screw (28) from control spool.
4. Remove 7/8-inch external retaining ring (22) from Super Spool™ sleeve (19). Remove sleeve from handle (1).
5. Remove O-rings (20, 21 and 23) from Super Spool™ sleeve (19). Remove O-ring (18) from handle (1).

## **Disassembly (VSD6400) (cont'd)**

### **Directional Spool**

1. Remove both #10 x 1/2-inch flat socket head cap screws (17) and buttons (16) from directional spool (14). Slide directional spool partway through the bore to expose one O-ring (15). Remove exposed O-ring.
2. Remove directional spool (14) by pushing it back through the bore. Remove remaining O-ring (15).

*Note: Attempting to push directional spool (14) all the way through the bore in one direction will cause damage to O-rings (15) and could allow particles of O-rings to get into motor.*

### **Flow Control Cartridge**

Remove 11/16 internal retaining ring (9). Pull flow control cartridge (6) out of handle. Remove O-rings (7 & 8) from cartridge.

*Note: Do not disassemble flow control cartridge. If necessary, replace with a new, factory-preset cartridge.*

### **Adjustable Torque Output Screw**

Remove spring pin (13) from handle. Turn torque output screw (10) counterclockwise until threads are free. Pull screw out of handle. Remove O-ring (11) and backup ring (12) from screw.

## Inspection (H6400C, H6400C1 & VSD6400)

Clean all parts with an appropriate cleaning solution and dry them thoroughly. Inspect each component as described in this section. Replace any component that shows wear or damage.

1. Bearings: Insert shaft into bearings. Spin shaft. If the shaft does not spin smoothly, replace the entire assembly with bearings already pressed in.
2. Motor Cap and Case: Inspect mating surfaces, bores, oil passageways, etc. for grooves or nicks. If any component shows wear or damage, replace the entire assembly with bearings already pressed in.
3. Drive Shaft and Idler Shaft: Inspect all surfaces, including gear teeth, for grooves or nicks.
4. Outer Race, Inner Race and Steel Balls: Insert balls into outer race. Assemble inner race and insert shaft. Spin shaft. If the shaft does not spin smoothly, replace the inner race and steel balls. If the outer race shows wear or damage, replace the entire handle with the outer race already pressed in.
5. Planet Gear with Needle Bearings: Insert dowel pin (43) into bearing. While holding the dowel between a thumb and forefinger, roll the gear in the palm of your other hand. If either gear does not spin smoothly, replace both gears with bearings already pressed in.
6. Inspect all other disassembled components for cracks, grooves or nicks.

## Assembly (H6400C & H6400C1)

Refer to the Illustration(s) and Parts List for correct orientation and placement of parts.

Replace any O-rings, V-rings, seals, and gaskets on parts that have been disassembled. Apply hydraulic fluid or O-ring lubricant to all O-rings and all metal surfaces which they must slide over. When installing an O-ring which must slide over sharp surfaces, use a rolling motion and be careful not to damage the O-ring.

Wherever the assembly results in metal-to-metal contact, coat the surfaces with hydraulic fluid or O-ring lubricant.

Some steps of the assembly procedure require a removable type of thread sealing and locking compound, such as Loctite® 242® or equivalent. Follow the manufacturer's instructions for curing.

### Motor

1. Install a new O-ring (4) into handle (1) using an O-ring tool.
2. Lubricate the 1/16" radius of the outer race (8) liberally with grease. Install the eighteen steel balls (9) into the outer race, allowing the grease to hold the balls in place.
3. Install the inner race (10). Install the drive shaft with gear (11).
4. Install Woodruff key (13) to the drive shaft. Slide one gear (12) onto the drive shaft by aligning the keyway in the gear with the Woodruff key. Secure the gear with the retaining ring (14).
5. Install the drive pin (16) into the idler shaft (15). Slide the other gear (12) onto the idler shaft by aligning the keyway in the gear with the drive pin.
6. Install the idler shaft assembly into the handle, meshing the two gears (12).
7. Install two dowel pins (17) into the handle (1). Install a new gasket (18).
8. Assemble motor cap (6) to handle (1), aligning the scribe marks. Secure with eight cap screws (19). Using the sequence shown here, torque to 9 Newton-meters (80 inch-pounds).



**Assembly (cont'd)**

**Torque Sequence**

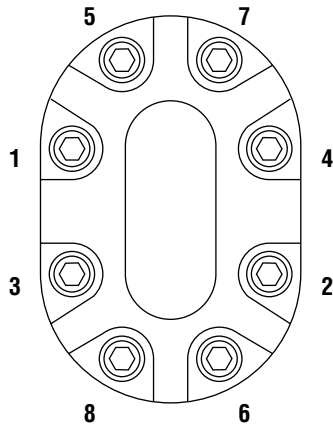

**Directional Spool**

1. Assemble one O-ring (21) to the directional spool (20).
2. Slide the direction spool into the handle just far enough to expose the O-ring groove. Install the second O-ring (21).
3. Apply a thread-locking compound to the threads of the cap screws (23). Assemble the buttons (22) to the spool and secure with the cap screws. Torque to 3.4 to 3.9 Newton-meters (30 to 35 inch-pounds).

**Trigger, Control Spool, and Super Spool Sleeve**

1. Install the O-ring (24) into the handle.
2. Assemble the O-rings (25A, 26, 27) to the sleeve (25). Slide the sleeve assembly (25) into the handle from the motor cap side. Secure with the retaining ring (31).
3. Install an O-ring (29) onto the control spool (28). Slide the spool into the sleeve (25). Apply a thread-locking compound to the cap screw (30) and install it into the control spool (28). Tighten securely.
4. Slide the spring (32), washer (33) and trigger (37) onto the control spool (28). Secure the trigger with the machine screw (38) and nut (39). Tighten to allow the trigger to move freely.
5. Secure the links (34) to the handle (1) and trigger (37) using machine screws (35, 36) and nuts (39). Tighten to allow trigger to move freely.

**Case Components**

1. Install the ring gear (2) into the handle (1), aligning the notch in the ring gear with the notch in the handle. Insert the dowel pin (3).
2. Install planet gears (42) and dowels (43) into the frame (41). The dowels must be flush with the surface that has the spindle protruding from it.
3. Slide the case (47 or 47A) over the spindle assembly.
4. Place the gasket (49) onto the handle (1). Set the case with spindle onto the handle, aligning the scribe marks. Mesh the planet gears (42) with the ring gear (2). Secure with four cap screws (50). Tighten securely.
5. *H6400C1 only:* Install the auxiliary handle (63).

**Chuck Installation**

1. Clean the tapered surface of the spindle (41) and the mating tapered surface of the chuck (51) with Loctite 755-59 Safety Solvent, or equivalent.
2. Apply two drops of Loctite Retaining Compound 35 to both tapered surfaces.
3. Retract the chuck jaws completely into the chuck (51). Set the chuck onto the spindle (41). Using a block of wood to protect the chuck, tap the chuck lightly into place with a hammer.
4. Allow the Loctite to cure before operating the tool.

**Whip Hoses and Fittings (H6400C1 only)**

*Note: Apply a thread sealant that is compatible with hydraulic fluid to the male threads of the fittings.*

1. Assemble the pressure hose components. Install the O-ring (60) and pressure hose assembly to the tool. Tighten all components securely.
2. Assemble the tank hose components. Install the O-ring (55) and tank hose assembly to the tool. Tighten all components securely.

## Assembly (VSD6400)

Refer to the Illustration(s) and Parts List for correct orientation and placement of parts.

Replace any O-rings, V-rings, seals, and gaskets on parts that have been disassembled. Apply hydraulic fluid or O-ring lubricant to all O-rings and all metal surfaces which they must slide over. When installing an O-ring which must slide over sharp surfaces, use a rolling motion and be careful not to damage the O-ring.

Wherever the assembly results in metal-to-metal contact, coat the surfaces with hydraulic fluid or O-ring lubricant.

Some steps of the assembly procedure require a removable type of thread sealing and locking compound, such as Loctite® 242® or equivalent. Follow the manufacturer's instructions for curing.

### Motor

1. Install a new O-ring (2) into handle (1) using an O-ring tool.
2. Lubricate the 1/16" radius of the outer race (28) liberally with grease. Install the eighteen steel balls (36) into the outer race, allowing the grease to hold the balls in place.
3. Install the inner race (37). Install the drive shaft with gear (53).
4. Install Woodruff key (39) to the drive shaft. Slide one gear (40) onto the drive shaft by aligning the keyway in the gear with the Woodruff key. Secure the gear with the retaining ring (42).
5. Install the drive pin (44) into the idler shaft (43). Slide the other gear (40) onto the idler shaft by aligning the keyway in the gear with the drive pin.
6. Install the idler shaft assembly into the handle, meshing the two gears (40).
7. Install two dowel pins (45) into the handle (1). Install a new gasket (46).
8. Assemble motor cap (47) to handle (1), aligning the scribe marks. Secure with eight cap screws (49). Using the sequence shown here, torque to 9 Newton-meters (80 inch-pounds).

### Torque Sequence

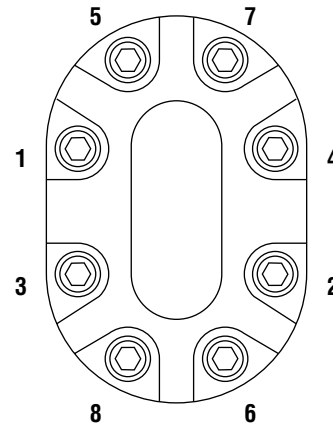

### Directional Spool

1. Assemble one O-ring (15) to the directional spool (14).
2. Slide the direction spool into the handle just far enough to expose the O-ring groove. Install the second O-ring (15).
3. Apply a thread-locking compound to the threads of the cap screws (17). Assemble the buttons (16) to the spool and secure with the cap screws. Torque to 3.4 to 3.9 Newton-meters (30 to 35 inch-pounds).

### Trigger, Control Spool, and Super Spool Sleeve

1. Install O-ring (18) in sleeve cavity of handle (1).
2. Install Super Spool™ sleeve (19) in handle (1). Secure sleeve in handle with 7/8-inch external retaining ring (22).
3. Install #6 x 1/4-inch pan head machine screw (28) in end of control spool (26), if removed. Install O-ring (27) on control spool.
4. Slide control spool (26) in Super Spool™ sleeve (19) from trigger side of handle (1). Install washer (30) in end of sleeve. Secure washer to sleeve with 5/8-inch internal retaining ring (31).
5. Secure trigger (32) to handle (1) with #10 x 1-1/4-inch round head machine screw (34) and hex elastic stop nut (35).
6. Attach connecting link (33) to trigger (32) and control spool (26).

## **Assembly (VSD6400) (cont'd)**

### **Flow Control Cartridge**

Install O-rings (7 & 8) on flow control cartridge (6).  
Install flow control cartridge in cavity of handle (1).  
Secure using 11/16 internal retaining ring (9).

### **Adjustable Torque Output Screw**

Install O-ring (11) and backup ring (12) on torque output screw (10). Install screw in cavity of handle (1). Turn screw clockwise until threads are engaged in threads of handle. Secure screw in handle using 5/64 x 7/8-inch spring pin (13).

### **Case Components**

1. Install the ring gear (4) into the handle (1), aligning the notch in the ring gear with the notch in the handle. Insert the dowel pin (5).
2. Install planet gears (55) and dowels (57) into the frame (56). The dowels must be flush with the surface that has the spindle protruding from it.
3. Slide the case (60) over the spindle assembly.
4. Place the gasket (58) onto the handle (1). Set the case with spindle onto the handle, aligning the scribe marks. Mesh the planet gears (55) with the ring gear (4). Secure with four cap screws (52). Tighten securely.
5. Install the auxiliary handle (59).

### **Chuck Installation**

1. Clean the tapered surface of the spindle (56) and the mating tapered surface of the chuck (51) with Loctite 755-59 Safety Solvent, or equivalent.
2. Apply two drops of Loctite Retaining Compound 35 to both tapered surfaces.
3. Retract the chuck jaws completely into the chuck (51). Set the chuck onto the spindle (56). Using a block of wood to protect the chuck, tap the chuck lightly into place with a hammer.
4. Allow the Loctite to cure before operating the tool.

Illustration—H6400C Reversible Drill

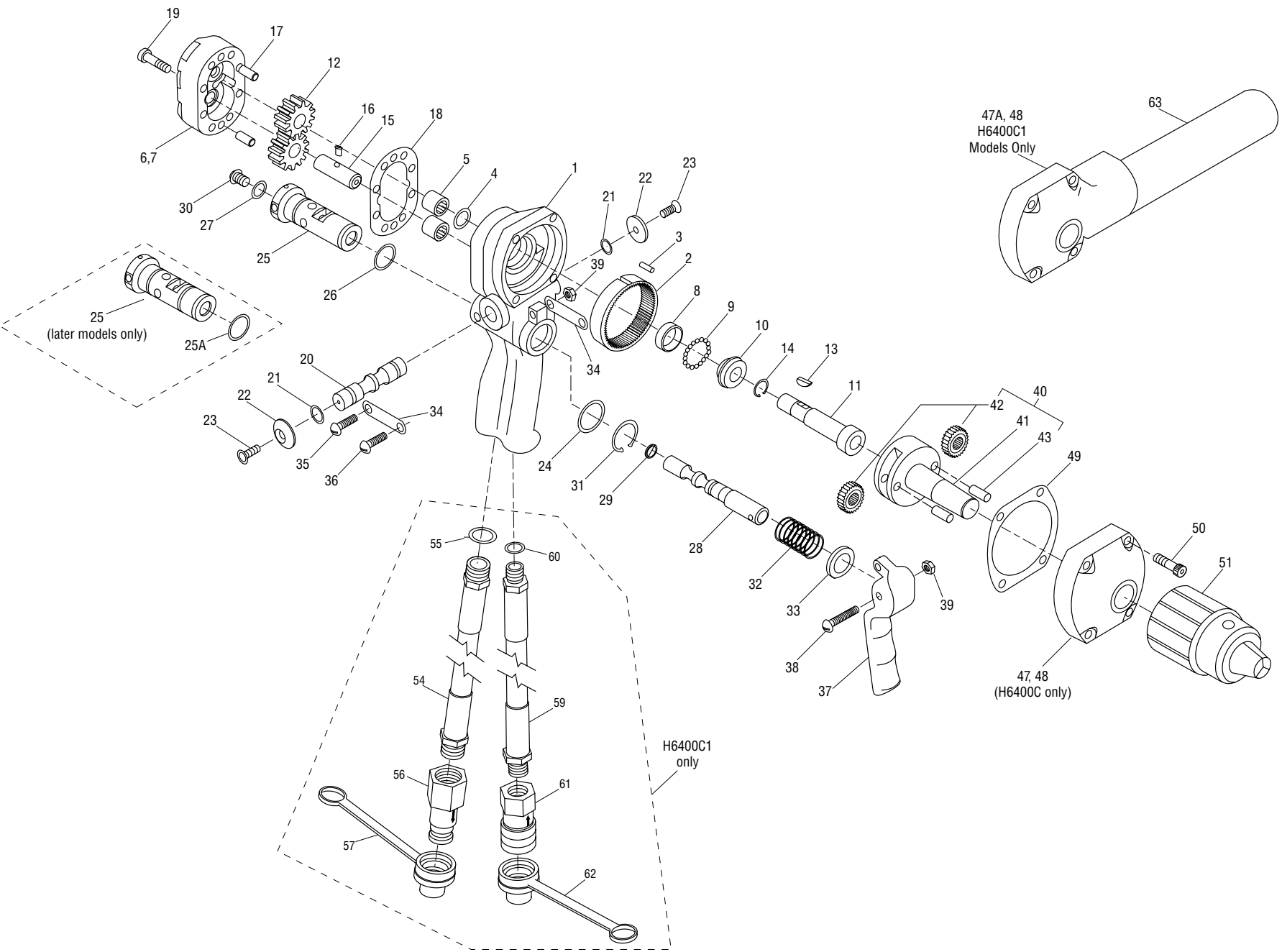

**Parts List—H6400C and H6400C1**

Key	UPC No.	Part No. 78-3310	Description	Qty	Key	UPC No.	Part No. 78-3310	Description	Qty
1	40584	128546	Handle, Insulated (includes items 2 - 5).....	1	33	40462	122755	Washer, Flat, .580 x .937 x .050, Stainless Steel.....	1
2	40152	103130	Gear.....	1	34	40463	122756	Link.....	2
3	41809	F020886	Dowel Pin, .125 x .500".....	1	35	41293	F007788	Screw, Machine, #10 – 24 x .875", Round Head.....	1
4*	41503	F015305	O-ring, .500 x .687 x .093" – 80.....	1	36	41307	F009591	Screw, Machine, #10 – 24 x .750", Round Head.....	1
5	41591	F016728	Needle Bearing, .439 x .625 x .500".....	2	37	40458	122403	Trigger.....	1
6	40412	118070	Motor Cap (includes item 7).....	1	38	41583	F016230	Screw, Machine, #10 – 24 x 1.25", Round Head.....	1
7	41591	F016728	Needle Bearing, .439 x .625 x .500".....	2	39	41676	F018029K	Nut, Hex, #10 – 24 x .187, Lock.....	3
8	40392	116575K1	Outer Race.....	1	40	40171	104172	Spindle Assembly (includes 41 - 43).....	1
9	41723	F018865	Ball, .125" Diameter, Steel.....	18	41	40172	104173K	Frame, Planet Gear.....	1
10	40393	116576K1	Inner Race.....	1	42	40418	118586K	Gear, 21-Tooth (with Needle Bearing).....	2
11	41222	156589	Drive Shaft with Gear.....	1	43	41624	F017014	Dowel Pin, .250 x .625".....	2
12	41630	F017105	Gear, 11-Tooth.....	2	47	40414	118099	Case Assembly, H6400C (includes item 48).....	1
13	41592	F016729	Woodruff Key, #213.....	1	47A	43076	128990	Case Assembly, H6400C1 (includes item 48).....	1
14	41621	F017010	Retaining Ring, .437", External.....	1	48	41476	F014753	Bearing, Bronze.....	1
15	40168	104110K	Shaft, Idler.....	1	49*	40134	101524	Gasket.....	1
16	41593	F016730	Drive Pin, .123 x .209 with Square Head.....	1	50	41616	F016807	Screw, Cap, 1/4 – 20 x 1.00", Socket Head.....	4
17	41624	F017014	Dowel Pin, .250 x .625".....	2	51	41453	F014048K	Chuck.....	1
18*	41595	F016732	Gasket, 2.09 x 3.09 x .0015".....	1	54	40307	112350	Hose, 3/8 x 12".....	1
19	41616	F016807	Screw, Cap, 1/4 – 20 x 1.00", Socket Head.....	8	55*	41397	F012813	O-ring, .644 x .818 x .087" – 90.....	1
20	40215	105427	Spool, Directional.....	1	56	41779	F020197K	Coupler, Male.....	1
21*	41489	F015257	O-ring, .437 x .562 x .062" – 68.....	2	57	41834	F021406	Dust Cap.....	1
22	40228	106576	Button.....	2	59	40305	112348	Hose, 3/8 x 12".....	1
23	41715	F018627	Screw, Cap, #10 – 24 x .500", Flat Head.....	2	60*	41353	F011302	O-ring, .468 x .624 x .078" – 90.....	1
24*	41559	F015679	O-ring, .875 x 1.000 x .062" – 70.....	1	61	41777	F020195K	Coupler, Female.....	1
25	40585	128547	Sleeve, Super Spool (for serial numbers before 99273).....	1	62	41834	F021406	Dust Cap.....	1
25	41188	154724	Sleeve, Super Spool (for serial numbers after 99273).....	1	63	40465	122762	Auxiliary Handle (H6400C1 only).....	1
25A*	42089	F024419	O-ring, .787 x .889 x .051" – 70 (for serial numbers after 99273).....	1	*	40749	131394	Packing Kit (includes all items marked with an asterisk*).....	1
26*	41534	F015403	O-ring, .750 x .875 x .062" – 90.....	1					
27*	41371	F011762	O-ring, .437 x .625 x .093" – 90.....	1					
28	40640	130741K	Super Spool.....	1					
29*	41585	F016327	O-ring, .312 x .437 x .062" – 70.....	1					
30	41814	F020928	Screw, Cap, 5/16 – 18 x .375", Button Head Socket.....	1					
31	41298	F009117	Retaining Ring, .875, External.....	1					
32	41760	F019817	Spring, Compression, .635 x .845 x 1.25".....	1					

**PARTS AND SERVICE**

Illustrations—VSD6400 Reversible Drill

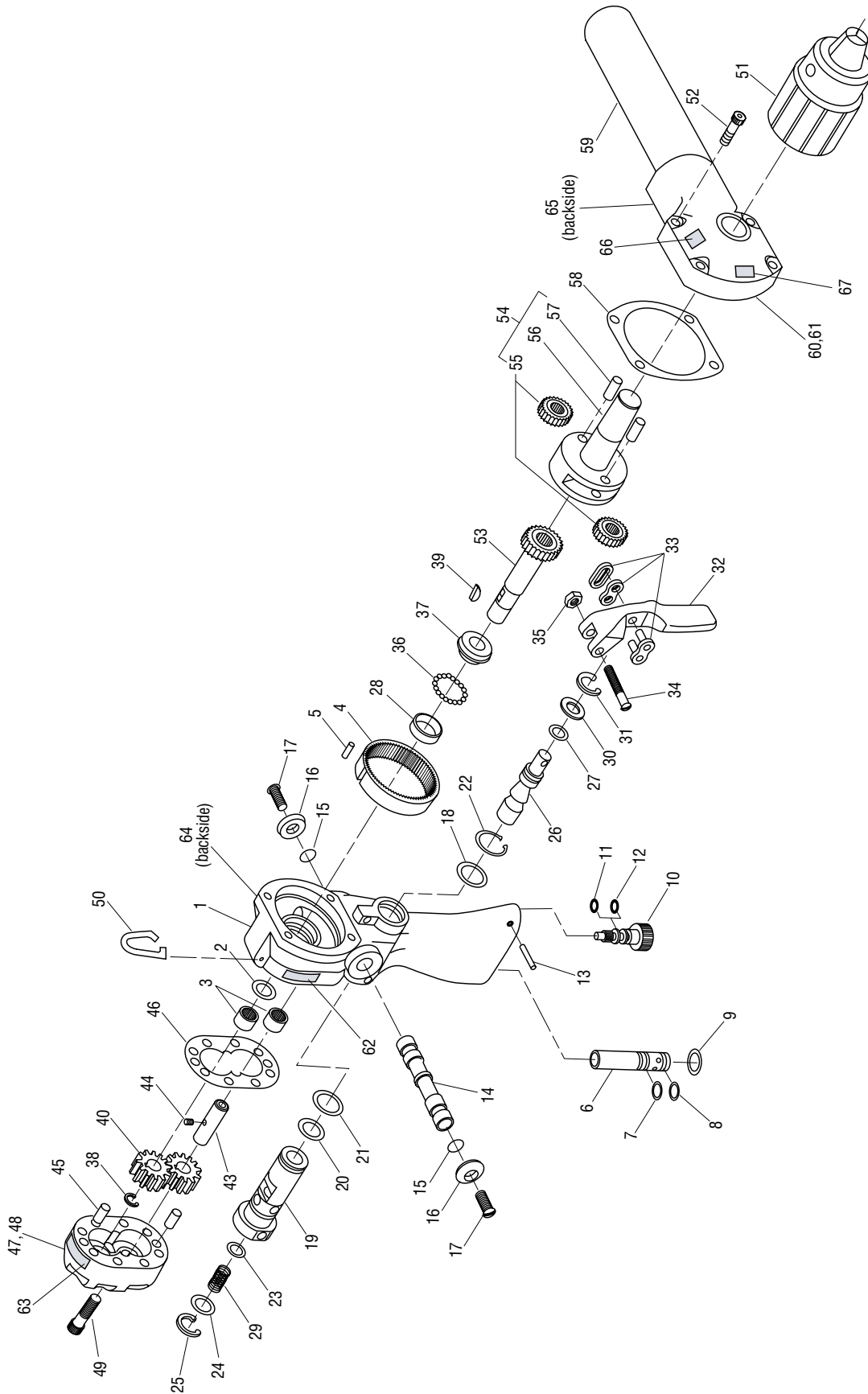

PARTS AND SERVICE

**Parts List—VSD6400**

Key	UPC No.	Part No. 78-3310	Description	Qty	Key	UPC No.	Part No. 78-3310	Description	Qty
	48759		HANDLE AND MOTOR ASSEMBLY .....	1	35	41676	F018029K	Hex Elastic Stop Nut, #10 .....	1
1	43482	138339	HANDLE ASSEMBLY with ORIFICE, BEARINGS and GEAR .....	1	36	41723	F018865	Ball, .125 dia. Steel .....	18
2*	41503	F015305	O-ring, 1/2 x 3/32 – 90 .....	1	37	40393	116576K1	Race, Inner .....	1
3	41591	F016728	Needle Bearing .....	2	38	41621	F017010	Retaining Clip, 25/64" External .....	1
4	40152	103130	Internal Gear .....	1	39	41592	F016729	Key, Woodruff #213 .....	1
5	42092	F024482	Spiral Pin, 1/8 x 1/2 .....	1	40	41630	F017105	Gear, 11 Tooth .....	2
6	43302	138338	FLOW CONTROL CARTRIDGE .....	1	43	40168	104110K	Shaft, Idler .....	1
7*	41491	F015261	O-ring, 1/2 x 1/16 – 70 .....	1	44	41593	F016730	Pin, Drive .....	1
8*	41627	F017078	O-ring, 7/16 x 1/16 –70 .....	1	45	41624	F017014	Dowel Pin, 1/4 dia. x 5/8 .....	2
9	41600	F016737	Retaining Ring, 11/16 Internal .....	1	46*	41595	F016732	Gasket .....	1
10	41094	138311	Screw, Adjustable Torque Output .....	1	47	40412	118070	Cap, Motor .....	1
11*	42729	L080005	O-ring, 1/4 x 1/16 – 70 .....	1	48	41591	F016728	Bearing, Needle .....	2
12*	41843	F021471	Backup Ring .....	1	49	41616	F016807	Socket Head Cap Screw, 1/4 – 20 x 1 .....	8
13*	42053	F023467	Spring Pin, 5/64 x 7/8 .....	1	50	43817	F023463	Hook, Lift .....	1
14	40215	105427	Spool, Directional .....	1	51	41453	F014048K	Chuck .....	1
15*	41489	F015257	O-ring, 7/16 x 1/16 – 68 .....	2	52	41616	F016807	Socket Head Cap Screw .....	4
16	40228	106576	Button .....	2	53	41222	156589	Shaft, Drive (w/gear) .....	1
17	41715	F018627	Flat Socket Head Cap Screw, #10 x 1/2 ...	2	54	40171	104172	Assembly, Spindle .....	1
18*	41559	F015679	O-ring, 7/8 x 1/16 – 70 .....	1	55	40418	118586K	Gear, 21 Tooth (w/bearing) .....	2
19	41097	138315	Sleeve, Super Spool .....	1	56	40172	104173K	Frame, Planet Gear .....	1
20*	42089	F024419	O-ring, .787 x .051 – 70 .....	1	57	41624	F017014	Dowel Pin, 1/4 dia. x 5/8 .....	2
21*	41534	F015403	O-ring, 3/4 x 1/16 – 90 .....	1	58*	40134	101524	Gasket .....	1
22	41298	F009117	Retaining Ring, 7/8 External .....	1	59	40465	122762	Handle, Auxiliary .....	1
23*	41371	F011762	O-ring, 7/16 x 3/32 – 90 .....	1	60	43076	128990	Assembly, Case .....	1
24	41095	138312	Cap .....	1	61	41476	F014753	Bearing, .752 I.D. .....	1
25	41712	F018511	Retaining Ring, 3/4 Internal .....	1	62*	49766	49766	Decal, Fairmont .....	1
26	48681	48681	Spool, Control .....	1	63*	49500	49500	Decal, Warning .....	1
27*	41585	F016327	O-ring, 5/16 x 1/16 – 70 .....	1	64*	49764	49764	Decal, Pressure/Flow/Weight .....	1
29	42865	L089019	Spring, Compression .....	1	65*	49489	49489	Decal, Spool Rotation .....	1
30	41096	138313	Washer .....	1	66*	49506	49506	Decal, CE .....	1
31	41297	F008797	Retaining Ring, 5/8 Internal .....	1	67*	49592	49592	Decal, Sound .....	1
32	40406	118061	Trigger .....	1	*	49765	49765	Seal Kit (includes all items marked with an asterisk*)	
33	41636	F017345	Connecting Link .....	1					
34	41583	F016230	Slotted Round Head Machine Screw, #10 x 1-1/4 .....	1					

**PARTS AND SERVICE**

# **GREENLEE **TEXTRON****

**Greenlee Textron / Subsidiary of Textron Inc.**

4455 Boeing Drive, Rockford, IL 61109-2988 USA

Customer Service (International): 815/397-7070 • Fax: 815/397-9247

Customer Service (North America): 800/435-0786 • Fax: 800/451-2632, 815/397-1865

Canada Fax: 800/524-2853

Printed in the U.S.A.