

SERVICE DATA SHEET

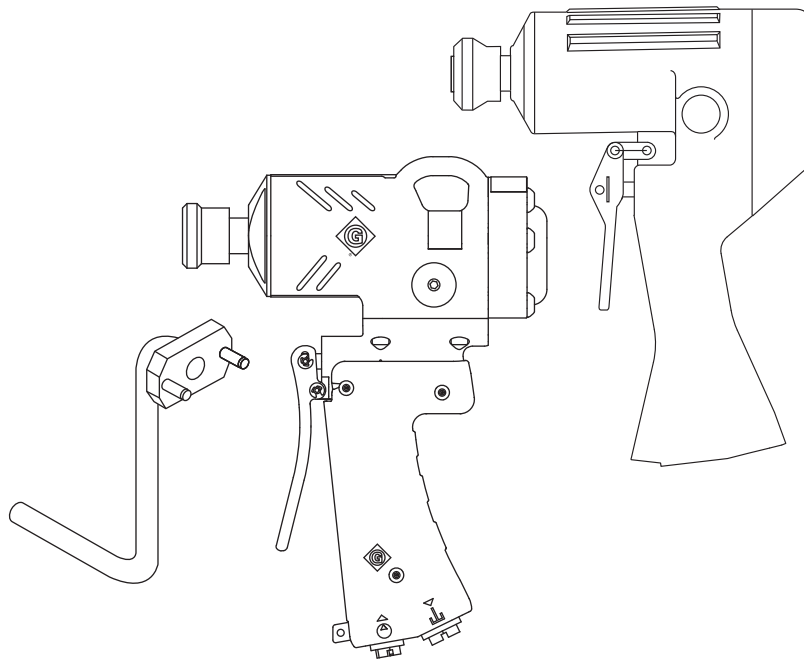

GREENLEE®
UTILITY
A Textron Company



49004

Relief Pressure Check Kit

for H8508 Series and HW1 Series

Impact Wrenches



Read and understand all of the instructions and safety information in this manual before operating or servicing this tool.

Register this product at www.greenlee.com

Table of Contents

Safety	2
Purpose of this Manual	2
Other Publications	2
Important Safety Information	2
Setting Relief Valve Pressure.....	3-7
Preparing Tool for Pressure Test: H8508 Series and HW1 Sereis	3-4
Checking Relief Valve Pressure	5
Checking Relief Valve Pressure—Forward: H8508 Series Only	5
Checking Relief Valve Pressure—Reverse: H8508 Series Only	5
Checking Relief Valve Pressure—Forward: HW1 Series Only.....	6
Assembly: H8508 Series and HW1 Series	7

Safety

Safety is essential in the use and maintenance of Greenlee tools and equipment. This manual and any markings on the tool provide information for avoiding hazards and unsafe practices related to the use of this tool. Observe all of the safety information provided.

Purpose of this Manual

This manual is intended to familiarize all personnel with the safe service procedures for the following Greenlee Utility tool:

49004 Relief Pressure Check Kit for H8508 and HW1 Impact Wrenches

Keep this manual available to all personnel.

Replacement manuals are available upon request at no charge at www.greenlee.com.

Other Publications

Operation Manuals:
 Publication 52041909—H8508 Series
 Publication 52060654—HW1 Series

Service Manuals:
 Publication 52041908—Model H8508-1
 Publication 52041909—Model H8508-1V
 Publication 52041931—Model H8508-3
 Publicaiton 52041932—Model H8508-3V
 Publication 52060655—Model HW1
 Publication 52061484—Model HW1V

IMPORTANT SAFETY INFORMATION



SAFETY ALERT SYMBOL

This symbol is used to call your attention to hazards or unsafe practices which could result in an injury or property damage. The signal word, defined below, indicates the severity of the hazard. The message after the signal word provides information for preventing or avoiding the hazard.

⚠ DANGER

Immediate hazards which, if not avoided, **WILL** result in severe injury or death.

⚠ WARNING

Hazards which, if not avoided, **COULD** result in severe injury or death.

⚠ CAUTION

Hazards or unsafe practices which, if not avoided, **MAY** result in injury or property damage.

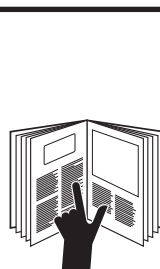

⚠ WARNING

The person(s) performing service must be trained in the operation and use of the H8508 and HW1. Read and understand the Operation Manual supplied with the tool, which is listed under "Other Publications," before proceeding with service.

Failure to observe this warning could result in severe injury or death.

All specifications are nominal and may change as design improvements occur. Greenlee Textron Inc. shall not be liable for damages resulting from misapplication or misuse of its products.

KEEP THIS MANUAL

Setting Relief Valve Pressures

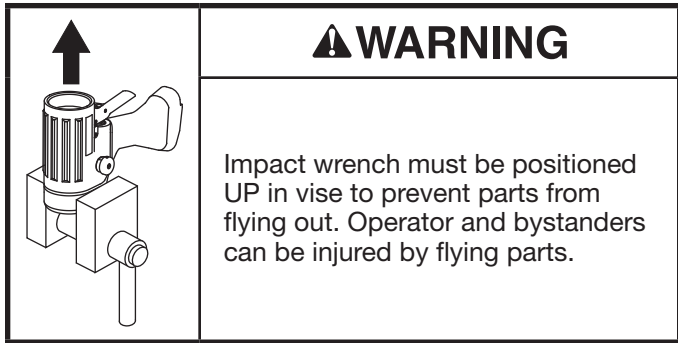

Preparing Tool for Pressure Test: H8508 Series and HW1 Series

1. Secure H8508 or HW1 in vise.
2. Unscrew and remove hammer case cap assembly (1), which includes the anvil and quick-change chuck mechanism.
3. Remove hammer frame (2) from the handle casting and remove the hammers (3) and hammer pins (4).

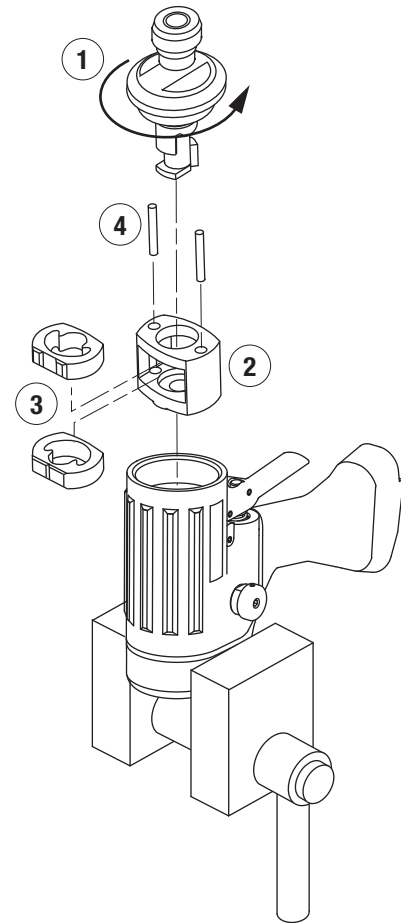

4. Reinstall hammer frame (2) only, on splined shaft.
5. Install a pressure gauge in line with the pressure line (gauge should be rated for 2000 psi minimum).

Setting Relief Valve Pressures (cont'd)

Preparing Tool for Pressure Test: H8508 Series and HW1 Series (cont'd)

6. Connect pressure and return lines to proper ports.
 A fluid power source of 5 gpm at 2000 psi is required.

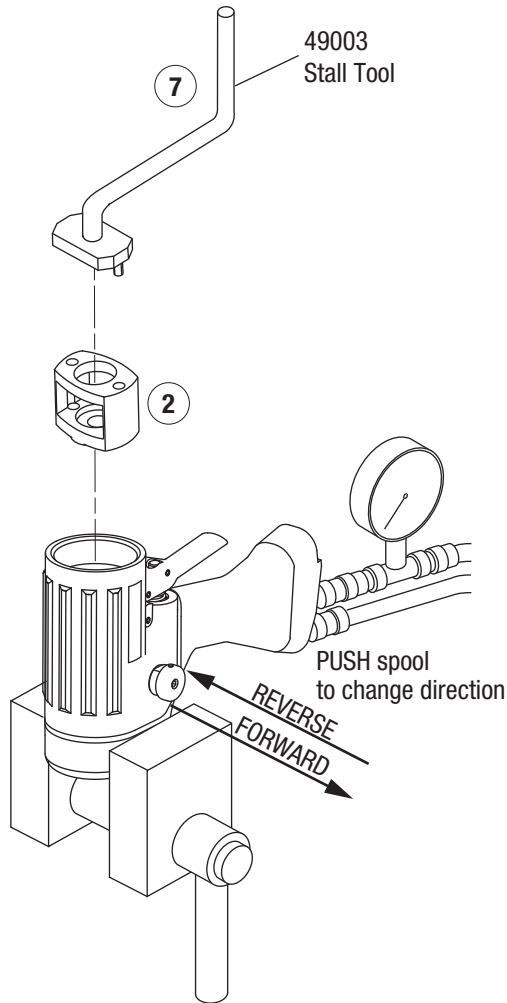

H8508 Series

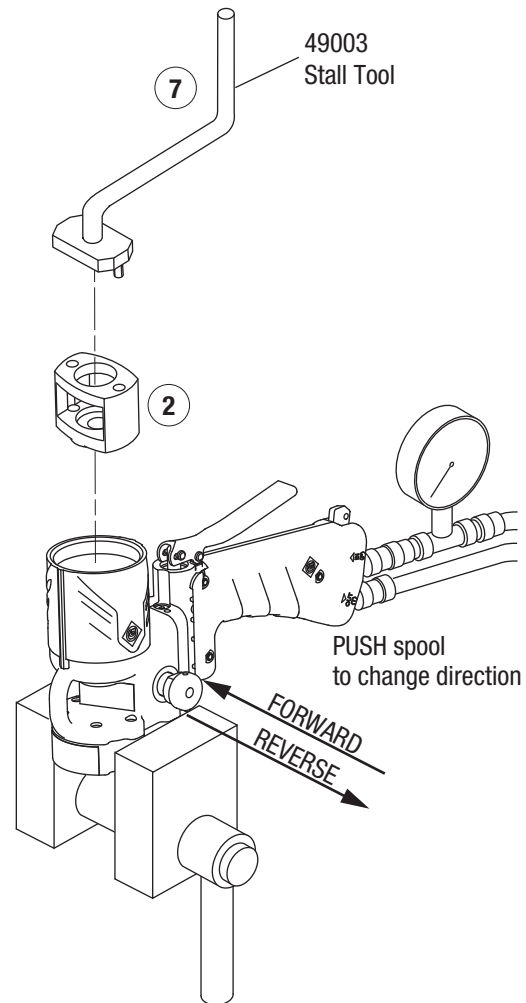

HW1 Series

⚠ WARNING

- Do not lean over the vise or put your face in path of the stall tool.
- Hold stall tool firmly before actuating trigger. Up to 80 in-lb of torque may be delivered.

Failure to observe this warning could result in the stall tool rotating at high speed, causing parts to fly out. Injury could result from flying parts or rotating stall tool.

Setting Relief Valve Pressures (cont'd)

Checking Relief Valve Pressure

Note: The H8508 Series and HW1 Series have the reversing spools in opposite configurations for forward and reverse. Also, the HW1 Series has a self-biasing relief valve. Therefore, there is only one relief valve in the reversing spool, which when adjusted will set both forward and reverse. The H8508 Series has two relief valves in the reversing spool, which must be set separately for each direction.

Checking Relief Valve Pressure—Forward: H8508 Series Only

1. Position FORWARD/REVERSE spool in FORWARD direction. (The shaft rotates counterclockwise while looking at the hammer frame.)
2. SLOWLY actuate trigger to check rotation direction of hammer frame. RELEASE TRIGGER.
3. Place stall tool 49003 (7) in hammer frame (2).
4. Hold handle securely and engage trigger to full ON position. Allow stall tool and hammer frame to rotate slowly. Read pressure on gauge.
5. Pressure at gauge should be 1300-1350 psi.
6. If pressure is not in range, loosen small locking set screw (5). Turn large set screw (6) IN to raise pressure and OUT to lower pressure.
7. Turn large set screw 1/4 turn at a time. Reset small locking set screw (5).
8. Repeat steps 1, 2, and 3, if necessary, until proper pressure setting is reached.

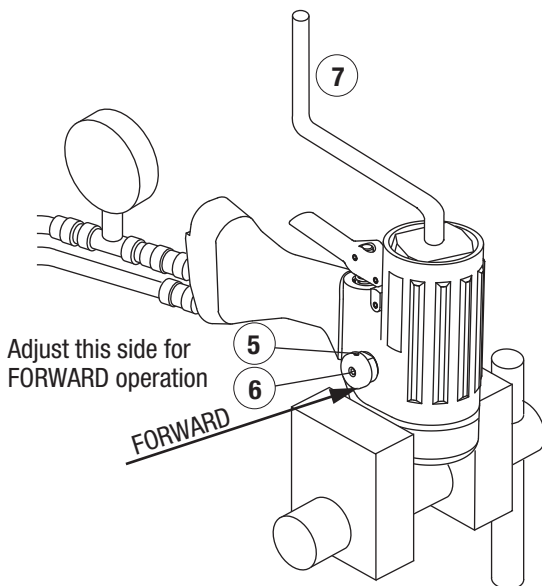

Checking Relief Valve Pressure—Reverse: H8508 Series Only

1. Position FORWARD/REVERSE spool in REVERSE direction (The shaft rotates clockwise while looking at the hammer frame.)
2. SLOWLY actuate trigger to check rotation direction of hammer frame. RELEASE TRIGGER.
3. Place stall tool 49003 (7) in hammer frame (2).
4. Hold handle securely and engage trigger to full ON position. Allow stall tool and hammer frame to rotate slowly. Read pressure on gauge.
5. Pressure at gauge should be 25 to 50 psi HIGHER than forward relief setting.
6. If pressure is not in range, loosen small locking set screw (5). Turn large set screw (6) IN to raise pressure and OUT to lower pressure.
7. Turn large set screw 1/4 turn at a time. Reset small locking set screw (5).
8. Repeat steps 4, 5, and 6, if necessary, until proper pressure setting is reached.

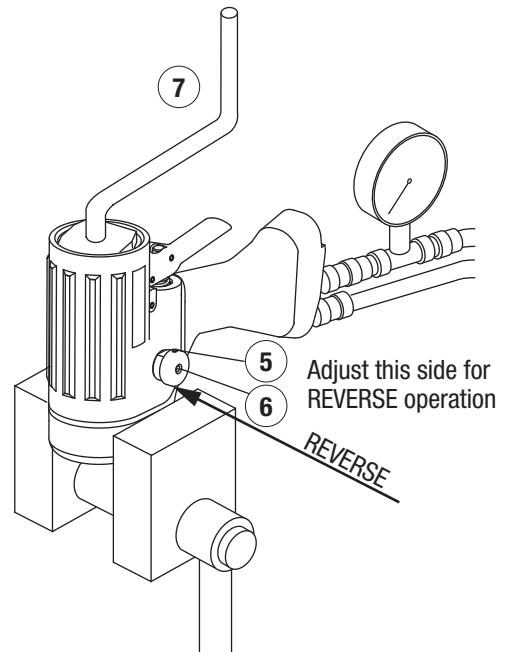

⚠ WARNING

- Do not lean over the vise or put your face in path of the stall tool.
- Hold stall tool firmly before actuating trigger. Up to 80 in-lb of torque may be delivered.

Failure to observe this warning could result in the stall tool rotating at high speed, causing parts to fly out. Injury could result from flying parts or rotating stall tool.

Setting Relief Valve Pressures (cont'd)

Checking Relief Valve Pressure—Forward: HW1 Series Only

1. Position FORWARD/REVERSE spool in FORWARD direction. (The shaft rotates counterclockwise while looking at the hammer frame.)
2. SLOWLY actuate trigger to check rotation direction of hammer frame. RELEASE TRIGGER.
3. Place stall tool 49003 (7) in hammer frame (2).
4. Hold handle securely and engage trigger to full ON position. Allow stall tool and hammer frame to rotate slowly. Read pressure on gauge.
5. Pressure at gauge should be 1300-1400 psi.
6. If pressure is not in range, loosen small locking set screw (5). Turn large set screw (6) IN to raise pressure and OUT to lower pressure.
7. Turn large set screw 1/4 turn at a time. Reset small locking set screw (5).
8. Repeat steps 1, 2, and 3, if necessary, until proper pressure setting is reached.

Note: HW1 Series has only one relief valve and setting only in FORWARD direction is required.

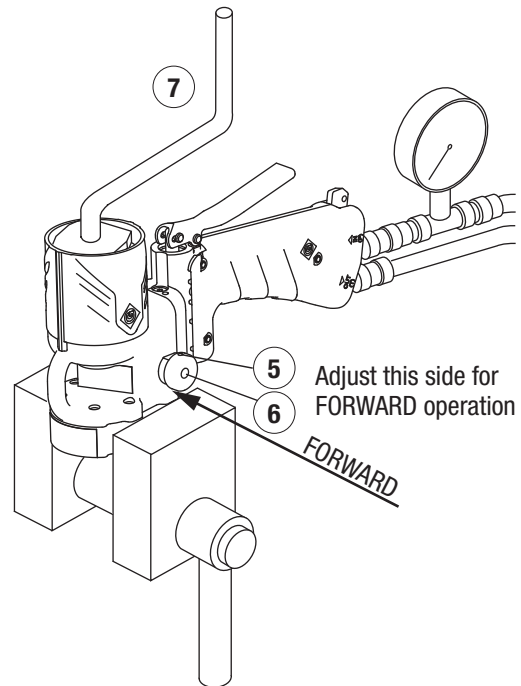

⚠ WARNING

- Do not lean over the vise or put your face in path of the stall tool.
- Hold stall tool firmly before actuating trigger. Up to 80 in-lb of torque may be delivered.

Failure to observe this warning could result in the stall tool rotating at high speed, causing parts to fly out. Injury could result from flying parts or rotating stall tool.

Setting Relief Valve Pressures (cont'd)

Assembly: H8508 Series and HW1 Series

1. Make sure locking set screws (5) are tight.
2. Recheck relief settings in both FORWARD and REVERSE positions (only FORWARD for HW1).
3. Turn off power source. Depressurize hydraulic system. Disconnect tool.

4. Apply a coat of Mobil Grease HP to hammers and hammer case. If necessary, apply a liberal amount of grease to the anvil.
5. Reinstall hammers (3), pins (4), and hammer case cap (1).

Note: The two hammers (3) must be positioned as shown.

⚠ WARNING

Do not disconnect tool, hoses, or fittings while the power unit is running or if the hydraulic fluid is hot. Exposure to hot hydraulic fluid can cause serious burns.

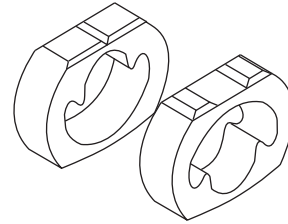

⚠ WARNING



Skin injection hazard:

- Do not use fingers or hands to check for leaks.
- Depressurize hydraulic system before servicing.

High pressure oil easily punctures skin causing serious injury, gangrene or death. If injured seek medical help immediately to remove oil.

6. Tool is now ready for use.



4455 Boeing Drive • Rockford, IL 61109-2988 • USA • 815-397-7070
An ISO 9001 Company • Greenlee Textron Inc. is a subsidiary of Textron Inc.

www.greenlee.com

USA Tel: 800-435-0786
Fax: 800-451-2632

Canada Tel: 800-435-0786
Fax: 800-524-2853

International Tel: +1-815-397-7070
Fax: +1-815-397-9247