

PARTS LIST

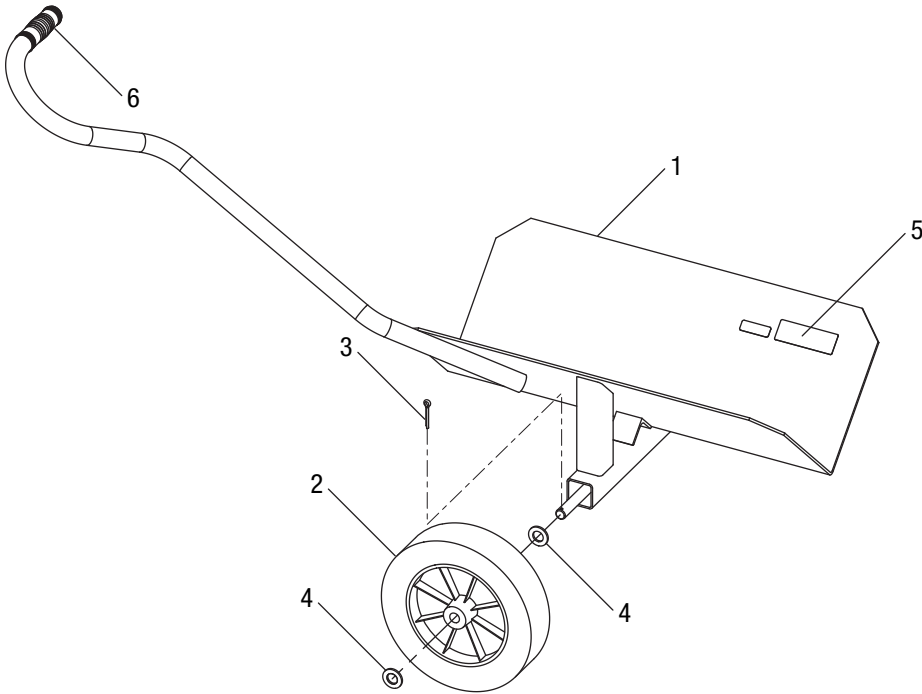

36745 Pipe Cart

Maximum Capacity:
1000 lb (454 kg) / 20" (508 mm) pipe size

<p>⚠ CAUTION</p> <p>Use on smooth, level surfaces.</p>

Key	Part No.	Description	Qty
1		Pipe cart weldment	1
2		Wheel	2
3		Pin, cotter.....	2
4		Washer, flat.....	4
5		Decal, ID.....	1
6		Grip.....	1

Wheel Replacement Kits
(each kit includes one wheel, one cotter pin, and two washers)

50021826	16" pneumatic wheel for 1" axle
52064236	12" non-flat wheel for 3/4" axle

	<p>GREENLEE www.greenlee.com 4455 Boeing Drive • Rockford, IL 61109-2988 • USA • 815-397-7070 An ISO 9001 Company • Greenlee Textron Inc. is a subsidiary of Textron Inc.</p>	<p>USA Tel: 800-435-0786 Fax: 800-451-2632</p>	<p>Canada Tel: 800-435-0786 Fax: 800-524-2853</p>	<p>International Tel: +1-815-397-7070 Fax: +1-815-397-9247</p>
--	--	---	--	---

Register this product at www.greenlee.com