

# SERVICE MANUAL

*Fairmont*<sup>®</sup>

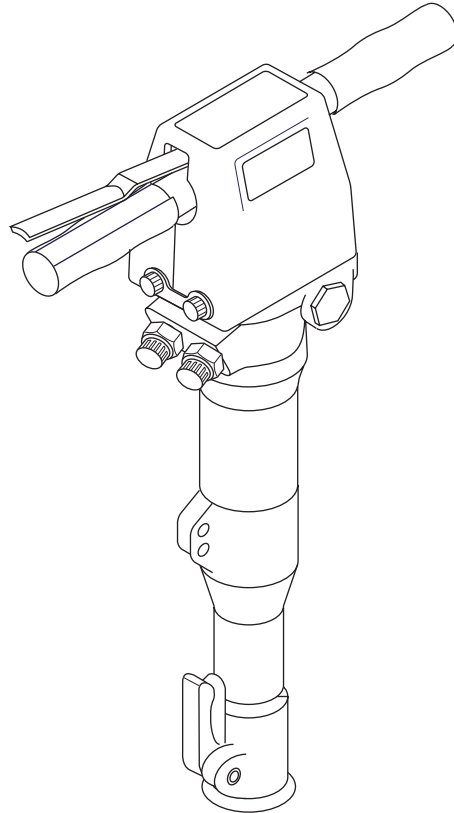

## **HPB45, HPB55, and HPB75 Hydraulic Paving Breakers**

Serial Codes GHE, GHF, GHH, GHJ, GHK, and GHL



**Read and understand** all of the instructions and safety information in this manual before operating or servicing this tool.

**Table of Contents**

Safety .....	2
Purpose of this Manual .....	2
Other Publications.....	2
Important Safety Information .....	3–4
Identification of Main Components .....	5
Maintenance.....	6–7
Troubleshooting.....	8–9
Repair .....	10
Disassembly .....	10
Main Components .....	11–12
Nose Part.....	13
Valve Housing .....	14
Trigger Valve .....	15
Accumulator.....	16
Cylinder.....	17
Handle.....	18
Assembly.....	19
Valve Housing .....	19–20
Cylinder.....	21
Accumulator.....	22
Main Components .....	23–25
Mounting of Bushing in Nose Part.....	26
Mounting of Latch in Nose Part.....	27
Adjustment of Dampening Handle.....	28
Main Illustration—All Models.....	29
Main Parts List—HPB45 and HPB55 .....	30
Main Parts List—HPB75.....	31
Standard Handle with Cover Illustration and Parts List—All Models .....	32
Dampening Handle with Cover Illustration and Parts List—All Models .....	33
Nose Part Illustration and Parts Lists.....	34

**Safety**

Safety is essential in the use and maintenance of Fairmont tools and equipment. This manual and any markings on the tool provide information for avoiding hazards and unsafe practices related to the use of this tool. Observe all of the safety information provided.

**Purpose of this Manual**

This manual is intended to familiarize all personnel with the safe service procedures for the following Fairmont tools:

HPB45-1	Serial Code GHE
HPB45-1AVS	Serial Code GHE
HPB45-2	Serial Code GHF
HPB45-2AVS	Serial Code GHF
HPB55-1	Serial Code GHH
HPB55-1AVS	Serial Code GHH
HPB55-2	Serial Code GHJ
HPB55-2AVS	Serial Code GHJ
HPB75-1	Serial Code GHK
HPB75-1AVS	Serial Code GHK
HPB75-2	Serial Code GHL
HPB75-2AVS	Serial Code GHL

Keep this manual available to all personnel.

Replacement manuals are available upon request at no charge at [www.greenlee.com](http://www.greenlee.com)

**Other Publications**

Instruction Manuals:

- Publication 99925427 (HPB45)
- Publication 99925435 (HPB55)
- Publication 99925443 (HPB75)

SAE Standard J1273 (Hose and Hose Assemblies):  
Publication 99930323

All specifications are nominal and may change as design improvements occur. Greenlee Textron shall not be liable for damages resulting from misapplication or misuse of its products.

Loctite is a registered trademark of Loctite Corporation.

**KEEP THIS MANUAL**

**IMPORTANT SAFETY INFORMATION**



**SAFETY ALERT SYMBOL**

This symbol is used to call your attention to hazards or unsafe practices which could result in an injury or property damage. The signal word, defined below, indicates the severity of the hazard. The message after the signal word provides information for preventing or avoiding the hazard.

**⚠ DANGER**

Immediate hazards which, if not avoided, **WILL** result in severe injury or death.

**⚠ WARNING**

Hazards which, if not avoided, **COULD** result in severe injury or death.

**⚠ CAUTION**

Hazards or unsafe practices which, if not avoided, **MAY** result in injury or property damage.

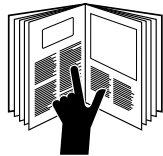

**⚠ WARNING**

Read and understand all of the instructions and safety information in this manual before operating or servicing this tool. Refer also to the instruction manuals, which are listed under "Other Publications."

Failure to observe this warning could result in severe injury or death.

**⚠ WARNING**



Skin injection hazard:

Oil under pressure easily punctures skin causing serious injury, gangrene or death. If you are injured by escaping oil, seek medical attention immediately.

- Do not use hands to check for leaks.
- Do not hold hose or couplers while the hydraulic system is pressurized.
- Depressurize the hydraulic system before servicing.

**⚠ WARNING**

Do not exceed the maximum hydraulic flow, pressure relief, or back pressure listed in the instruction manuals.

Failure to observe this warning could result in severe injury or death.

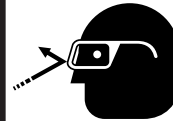

**⚠ WARNING**

Wear eye protection when operating or servicing this tool.

Failure to wear eye protection could result in serious eye injury from flying debris or hydraulic oil.



**⚠ WARNING**

Wear hearing protection when using this tool.

Failure to observe this warning could result in serious injury.

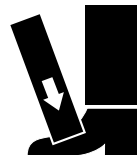

**⚠ WARNING**

Wear foot protection when using this tool.

Failure to observe this warning could result in serious injury.

**IMPORTANT SAFETY INFORMATION**

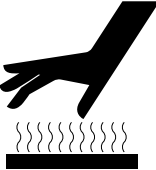
	<b>⚠ WARNING</b>
	<p>Tool, bit, and other components may be hot during and after operation. Allow to cool before handling, or handle with heat-resistant gloves.</p> <p>Failure to observe this warning could result in severe injury.</p>

<b>⚠ WARNING</b>
<p>Do not disconnect tool, hoses or fittings while the power source is running or if the hydraulic fluid is hot. Hot hydraulic fluid can cause serious burns.</p>

<b>⚠ WARNING</b>
<p>Do not reverse hydraulic flow. Operation with hydraulic flow reversed can cause tool malfunction. Connect the supply (pressure) hose and return (tank) hose to the proper ports.</p> <p>Failure to observe this warning could result in severe injury or death.</p>

<b>⚠ WARNING</b>
<p>Do not change accessories, inspect, adjust or clean tool when it is connected to a power source. Accidental start-up can result in serious injury.</p> <p>Failure to observe these warnings could result in severe injury or death.</p>

<b>⚠ WARNING</b>
<p>Accumulator is charged with nitrogen under high pressure. This pressure must be unloaded before dismounting.</p> <p>Failure to observe this warning could result in severe injury or death.</p>

<b>⚠ CAUTION</b>
<p>Hydraulic oil can cause skin irritation.</p> <ul style="list-style-type: none"> <li>• Handle the tool and hoses with care to prevent skin contact with hydraulic oil.</li> <li>• In case of accidental skin contact with hydraulic oil, wash the affected area immediately to remove the oil.</li> </ul> <p>Failure to observe these precautions can result in injury.</p>

<b>⚠ CAUTION</b>
<p>Perform repairs in accordance with manufacturer's instructions only. Repairs other than as described in this manual can result in injury and property damage.</p>

<b>⚠ CAUTION</b>
<p>All bolts on this tool are high tensile. Do not replace with bolts of lesser tensile specification.</p> <p>Failure to observe this precaution can result in injury and property damage.</p>

<b>IMPORTANT</b>
<p>Emergency stop procedure:</p> <ol style="list-style-type: none"> <li>1. Release the trigger.</li> <li>2. Shut off the hydraulic power source.</li> </ol>

<b>IMPORTANT</b>
<p>Procedure for connecting or disconnecting hydraulic hoses, fittings, or components:</p> <ol style="list-style-type: none"> <li>1. Move the flow lever on the hydraulic power source to the off position.</li> <li>2. Stop the hydraulic power source.</li> <li>3. Follow the sequence under "Hose Connections" in the instruction manual to prevent pressure buildup. In case some pressure has built up, loosen hoses, fittings, or components slowly.</li> </ol>

*Note: Keep all decals clean and legible, and replace when necessary.*

**Identification of Main Components**

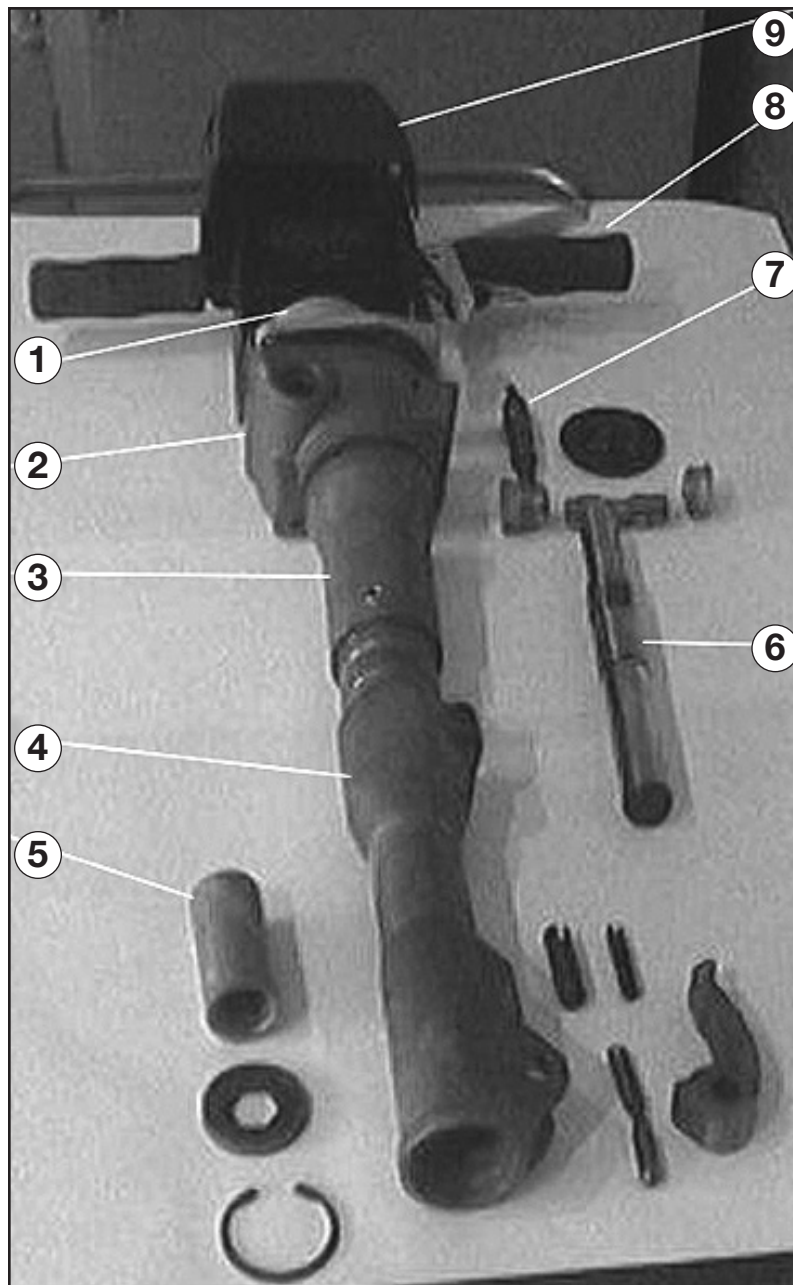

- |                           |                    |
|---------------------------|--------------------|
| 1. Accumulator (complete) | 6. Striking piston |
| 2. Valve housing          | 7. Trigger valve   |
| 3. Cylinder               | 8. Handle          |
| 4. Nose part              | 9. Cover           |
| 5. Chisel bushing         |                    |

**Maintenance**

Maintenance and repairs should be performed by qualified technicians.

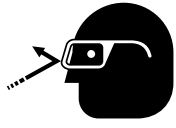
	<p><b>⚠ WARNING</b></p>
	<p>Wear eye protection when operating or servicing this tool. Failure to wear eye protection could result in serious eye injury from flying debris or hydraulic oil.</p>

<p><b>⚠ WARNING</b></p>
<p>Do not change accessories, inspect, adjust or clean tool when it is connected to a power source. Accidental start-up can result in serious injury. Failure to observe these warnings could result in severe injury or death.</p>

*Note: Use only recommended lubricants and hydraulic fluids. Refer to the instruction manuals, which are listed under "Other Publications."*

**Maintenance Schedule**

Use this maintenance schedule to maximize the tool's service life.

*Note: Keep all decals clean and legible. Replace decals when necessary.*

Daily

1. Wipe all tool surfaces clean.
2. Inspect the hydraulic hoses and fittings for signs of leaks, cracks, wear, or damage. Replace if necessary.
3. Install dust caps over the hydraulic ports when the tool is disconnected.

Monthly

Perform a thorough inspection of the hydraulic hoses and fittings as described in publication 99930323, SAE J1273 (Hose and Hose Assemblies).

Annually

If required by your organization, have the tool inspected by a Fairmont Authorized Service Center.

Perform the following maintenance procedures annually or after 500 hours of operation:

- Check and recharge the accumulator. Replace the diaphragm if it shows signs of cracks.
- Check moving parts, chisel bellows, screws, etc. and replace if necessary.
- Replace all seals.
- Test the function of the breaker.

**Storage**

If the tool requires long-term storage, protect the striking piston against corrosion. Press the striking piston to its upper position (through the chisel bushing) by means of a tool placed upside down. As the quick-release couplings are blocked when disassembled, the striking piston must be pressed upward with the hoses mounted but the power source turned off.

**Maintenance (cont'd)**

**Accumulator Recharging Procedure**

**▲ WARNING**

Accumulator is charged with nitrogen under high pressure. This pressure must be unloaded before dismounting.

Failure to observe this warning could result in severe injury or death.

1. Check that the oil inlet of the accumulator is depressurized.
2. Remove the protective cap over the charging screw (9) of the accumulator. The socket head screw must be perfectly clean.
3. Loosen the charging screw on top of the accumulator (maximum of two turns). Totally neutralize the pressure before dismounting the accumulator.
4. Unscrew the accumulator cover (10), take out the diaphragm (11), and check for leakage and damage.
5. Clean, check, and replace damaged or worn parts.
6. Grease the seal faces of the accumulator body (12) and the accumulator cover (10) with silicone.
7. Spray both sides of the diaphragm with silicone. Place the diaphragm with its bead pointing downward so that it fits in the groove of the accumulator body (12).
8. Unscrew the charging screw and replace the seal ring (13).
9. Grease the thread of the accumulator cover (10) with copper grease and tighten to approximately 200 Nm (148 ft-lb).
10. Fasten the charging screw lightly, and loosen it two turns afterward.
11. Mount the filling device on the filling socket of the accumulator cover and fasten it lightly while turning the handle (2) forward and backward, ensuring that the hexagon resiliently fits into the charging screw.
12. Close the bleeder valve (5) by turning it clockwise.
13. Connect the hose (7) to the check valve (6).
14. Connect the free end of the hose directly to the nitrogen bottle by using the reducing nipple.
 

*Note: Use only pure nitrogen.*
15. Read the pressure on the gauge (4). Carefully open the valve of the nitrogen bottle (1) and charge with nitrogen until the pressure is approximately 20% higher than required charging pressure. Close the valve of the nitrogen bottle.
16. If the gauge (4) shows too high a nitrogen pressure, loosen the bleeder valve (5) until the required pressure of 50 bar (723 psi) is achieved.

17. Close the charging screw (9) of the accumulator by turning the handle (2) clockwise.
18. Unload the nitrogen hose by opening the bleeder valve (5).
19. Dismount the filling device and check the charging screw (9) for leakage with drops of oil.
20. Fit the protective cap over the accumulator.

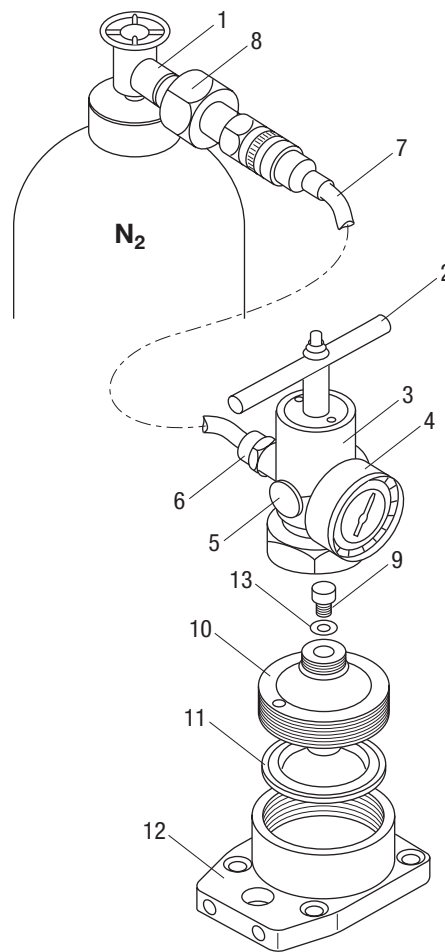

50027182 Accumulator filling device (includes items 2-8)

50027174 Accumulator kit (fully charged) (includes items 9-14)

- |                                     |                                 |
|-------------------------------------|---------------------------------|
| (1) Valve of nitrogen bottle        | (9) Charging screw              |
| (2) Handle                          | (10) Accumulator cover          |
| (3) Filling adaptor                 | (11) Diaphragm                  |
| (4) Gauge                           | (12) Accumulator body           |
| (5) Bleeder valve                   | (13) Seal ring                  |
| (6) Check valve                     | (14) Protective cap (not shown) |
| (7) Hose, approximately 3 m (10 ft) |                                 |
| (8) Reducing nipple (24.32-14WFG)   |                                 |

**Troubleshooting**

Before troubleshooting, determine whether the problem is in the tool, the hoses, or the power source. Substitute a tool, hoses, or power source known to be in good working order to eliminate the item that is not

If the problem is in the tool, refer to the troubleshooting table in this manual. If the problem is in the power source, refer to the troubleshooting section of the power source instruction manual.

Problem	Probable Cause	Probable Remedy
Tool does not operate.	Improper power source.	Verify that the power source meets the specifications.
	Hydraulic fluid level low.	Check the fluid level. Check system for leaks.
	Incorrect hydraulic fluid viscosity.	Use hydraulic fluid with the correct viscosity.
	No or incorrect flow/pressure.	Check flow/pressure by using test equipment.
	P and T hoses interchanged.	Check connection. With standard connection oil flows from male Q.R. coupling (i.e., tail-hose of tool's P connection is fitted with female coupling).
	Insufficient activation of trigger valve.	Adjust trigger lever (if adjustable) or replace defective parts.
	Defective seals in spool canal of valve housing.	Dismount, check, and replace seals.
	Back pressure too high.	Make direct tank connection. Max. back pressure 15 bar (200 psi) measured at tool.
	Defective Q.R. coupling in return line.	Locate and replace defective coupling.
	Striking piston sticks, possibly due to thickening of cylinder.	<p>Push tool hard against chisel.</p> <p>Chamfer/polish slightly the edge at cylinder dashpot (where cylinder bore changes size).</p> <p>Check oil viscosity. Thin oil increases risk of thickening.</p>
Spool/reversing spool or auxiliary spools stick.	Dismount and check that all parts move easily. Polish slightly if necessary.	



**Troubleshooting** (cont'd)

Problem	Probable Cause	Probable Remedy
Tool operates slowly or erratically.	Hydraulic fluid cold.	Allow fluid to warm to the operating temperature. Actuate the tool intermittently to reduce the warming time.
	Power source not adjusted correctly.	Refer to the power source operator's manual. Set the flow and pressure to correspond with the tool.
	Hydraulic fluid level low.	Check the fluid level. Check system for leaks.
	Air in the hydraulic system.	Refer to the power source manufacturer's instructions for removing air from the system.
	Incorrect hydraulic fluid viscosity.	Use hydraulic fluid with the correct viscosity.
	Defective seals.	Dismount, check, and replace.
	Wear, internal leakage.	Dismantle, check, and replace defective or worn parts.
Strike rate is normal; blow energy is weak.	Low accumulator gas pressure.	Return tool to a Fairmont Authorized Service Center.
	Broken accumulator diaphragm.	Return tool to a Fairmont Authorized Service Center.
Tool feels hot.	Hydraulic fluid level low.	Check the fluid level. Check for leaks.
	Incorrect hydraulic fluid viscosity.	Use hydraulic fluid with the correct viscosity.
	Hydraulic fluid dirty.	Refer to the power source owner's manual for procedure to replace hydraulic oil and filter.
Hoses pulsate.	Defective accumulator.	Replace accumulator diaphragm and charge with nitrogen. Refer to "Accumulator Recharging Procedure" in the "Maintenance" section of this manual.
Oil leaks from breaker.	Defective seals.	Replace seals.
Chisel falls out.	Worn latch.	Replace latch and roll pins.
	Worn chisel bushing or chisels.	Replace bushing or chisel.

**Repair**

Maintenance and repairs should be performed by qualified technicians.

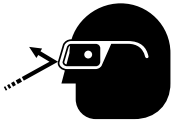
	<p><b>⚠ WARNING</b></p>
	<p>Wear eye protection when operating or servicing this tool. Failure to wear eye protection could result in serious eye injury from flying debris or hydraulic oil.</p>

<p><b>⚠ WARNING</b></p>
<p>Do not change accessories, inspect, adjust or clean tool when it is connected to a power source. Accidental start-up can result in serious injury. Failure to observe these warnings could result in severe injury or death.</p>

<p><b>⚠ WARNING</b></p>
<p>Accumulator is charged with nitrogen under high pressure. This pressure must be unloaded before dismantling. Failure to observe this warning could result in severe injury or death.</p>

<p><b>⚠ CAUTION</b></p>
<p>Perform repairs in accordance with manufacturer's instructions only. Repairs other than as described in this manual can result in injury and property damage.</p>

**Torque Settings**

Only use the torque settings indicated in this manual.

<p><b>⚠ CAUTION</b></p>
<p>All bolts on this tool are high tensile. Do not replace with bolts of lesser tensile specification. Failure to observe this precaution can result in injury and property damage.</p>

**Tools Required**

- Hex wrench, 8 mm
- Hex wrench, 10 mm
- Hex socket, 41 mm
- Adjustable torque wrench, 45 Nm to 200 Nm (33 ft-lb to 148 ft-lb)
- Tool for accumulator, 500 2796.4
- Punch, ø37 mm (scraper)
- Punch, ø14 mm (scraper)
- Punch, ø44 mm (scraper)
- Punch, ø49 mm (scraper)
- Loctite<sup>®</sup> 245
- Loctite 648
- Copper grease, anti-seize
- Accumulator filling device, 500 2718.2
- Universal cleaner, OKS 2611

**Disassembly**

Complete disassembly of the tool is not recommended. If a complete overhaul is necessary, return the tool to your nearest Fairmont Authorized Service Center.

The disassembly procedure is divided into sections of the tool. Disassemble only the section(s) necessary to complete the repair.

Disassemble the tool on a flat, clean surface. Take care not to lose or damage any parts that may fall free during disassembly.

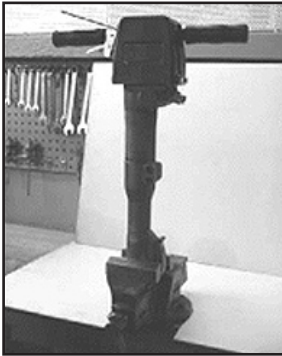
**Disassembly of Main Components**

1. Mount the breaker in a vise.



2. Loosen the nose part with a drill or torque wrench.



3. Dismount the nose part.

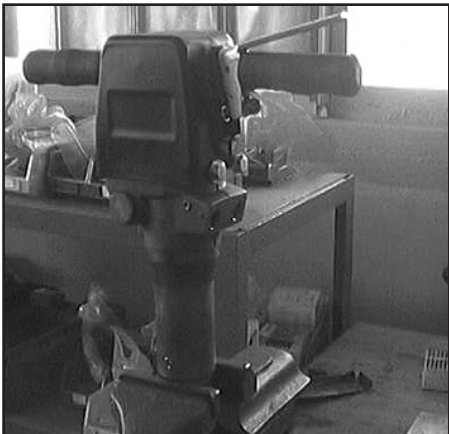

4. Remount the breaker in the vise.

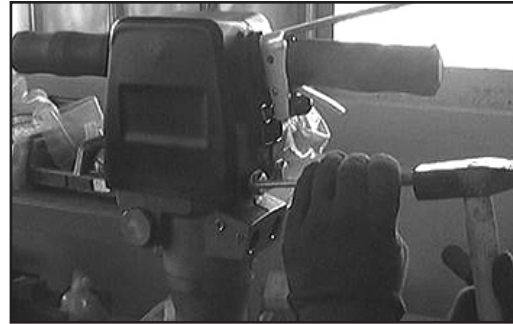

5. Hammer the nabs away from the screws.



6. Loosen the four screws.



7. Remove the screws.

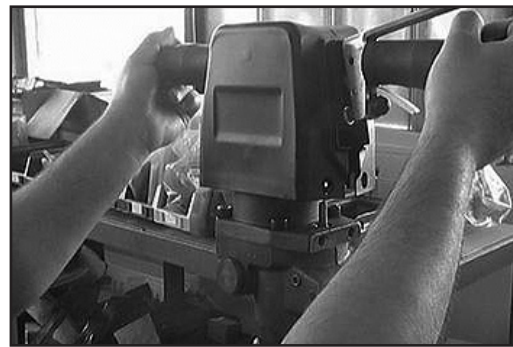

8. Remove the handle from the accumulator.

**Disassembly of Main Components (cont'd)**



9. Loosen the four screws on the accumulator.

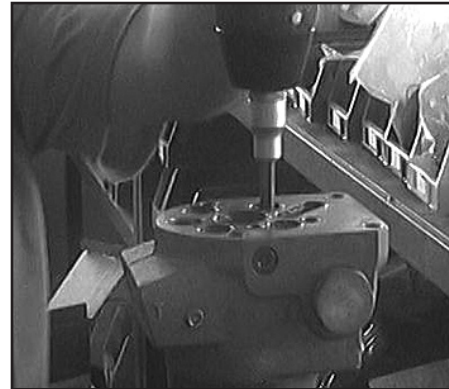

12. Loosen the screws in the valve housing.

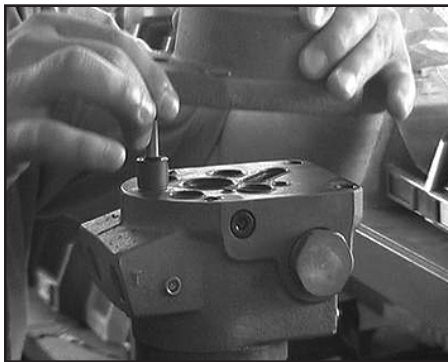

10. Remove the accumulator.

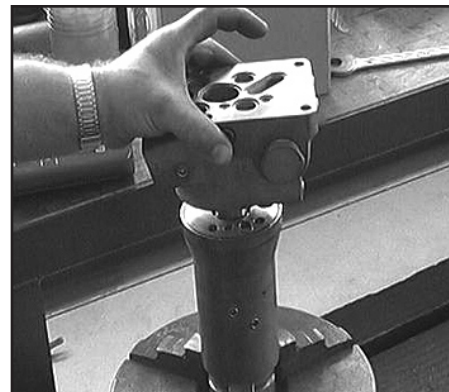

13. Remove the valve housing from the cylinder.

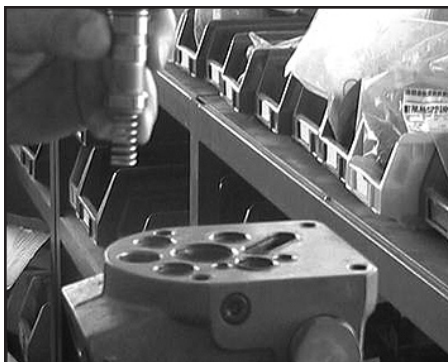

11. Remove the trigger valve.

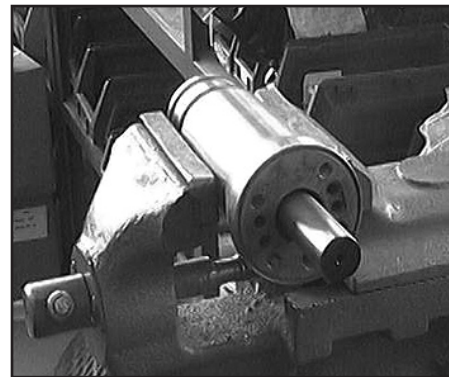

14. Remove the striking piston from the cylinder.

### Disassembly of Nose Part

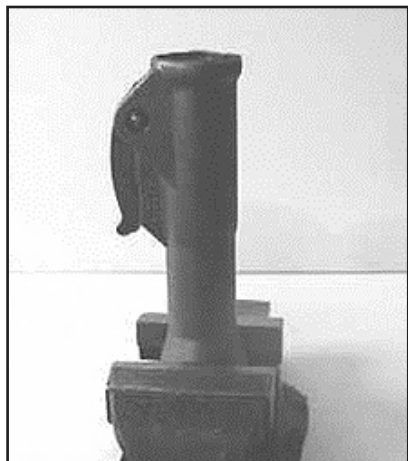

1. Mount the nose part in a vise.



4. Remove the locking ring.



2. Hammer out the two roll pins and remove the latch.



5. Remove the chisel bellows.

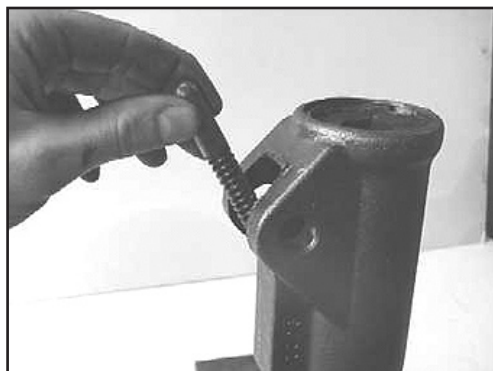

3. Remove the screw.

### Disassembly of Valve Housing

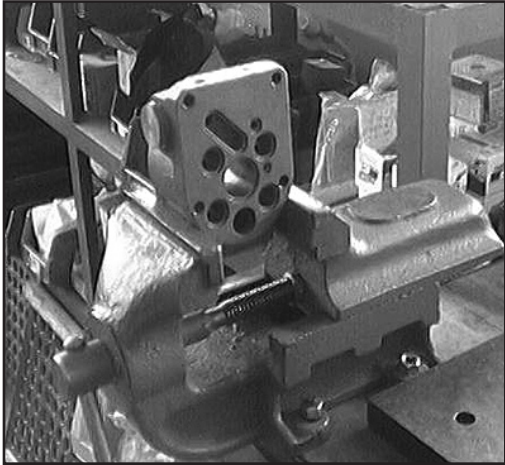

1. Mount the valve housing in a vise.

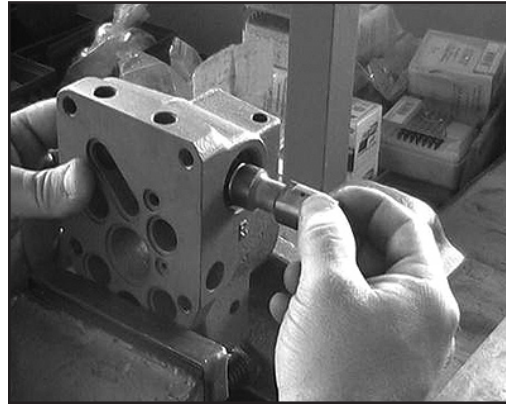

3. Remove the spool.

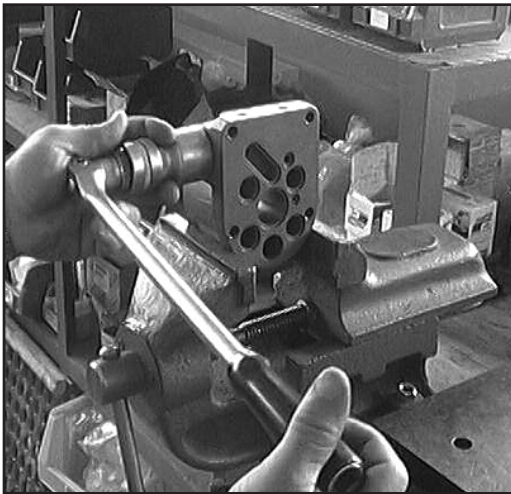

2. Loosen and remove the P and T guide sockets.

### Disassembly of Trigger Valve

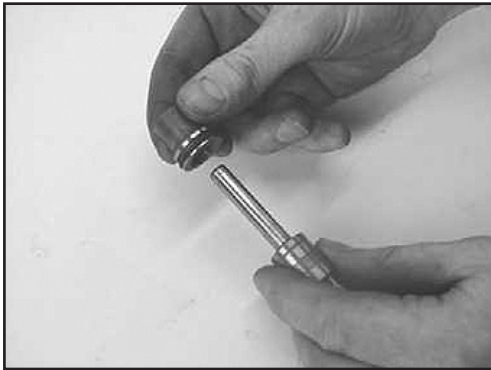

1. Remove the packing gland from the trigger.

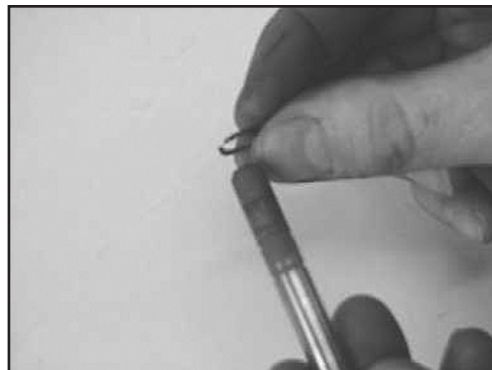

4. Remove the Seeger spring ring.

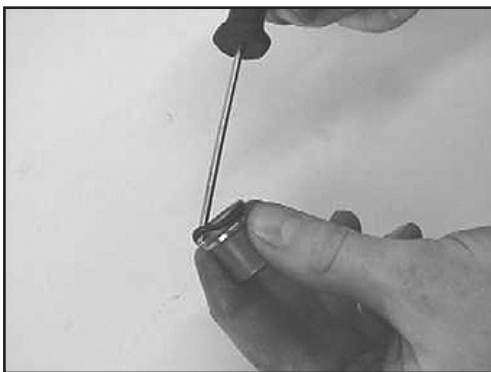

2. Remove the O-ring and seal from the packing gland.

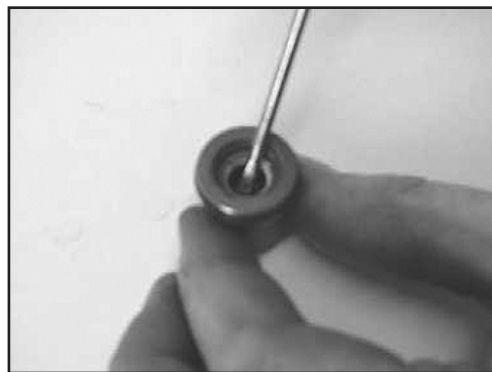

5. Remove the O-ring, backup ring, and Seeger spring ring from the trigger spool.

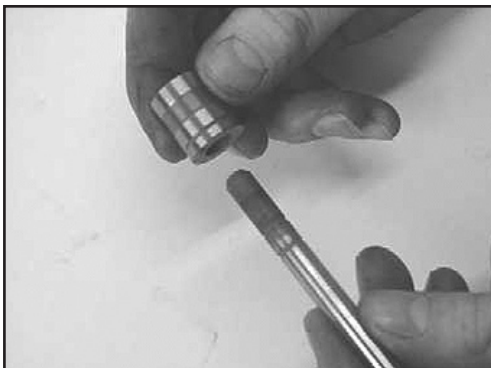

3. Remove the trigger spool from the trigger rod.

### Disassembly of Accumulator

#### **⚠ WARNING**

Accumulator is charged with nitrogen under high pressure. This pressure must be unloaded before dismantling.

Failure to observe this warning could result in severe injury or death.



4. Loosen the cover.

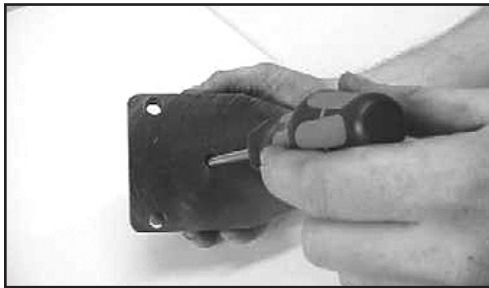

1. Check for gas by using the filling device or a screwdriver.

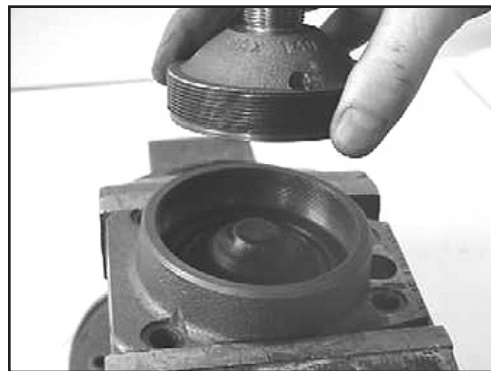

5. Remove the cover.

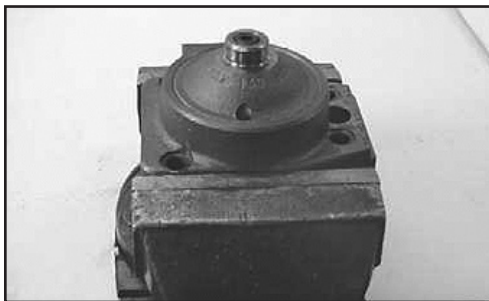

2. Mount the accumulator in a vise.



6. Remove the diaphragm.



3. Loosen the charging screw on the cover.



7. Check the diaphragm for defects.



### Disassembly of Cylinder



1. Mount the cylinder in a vise.



4. Remove the locking ring.



2. Remove the locking ring.



5. Remove the seal and backup washer.

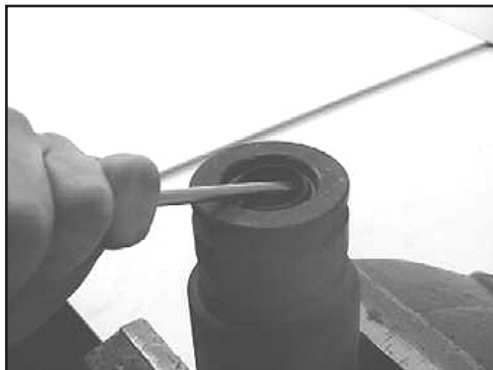

3. Remove the seal.

### Disassembly of Handle

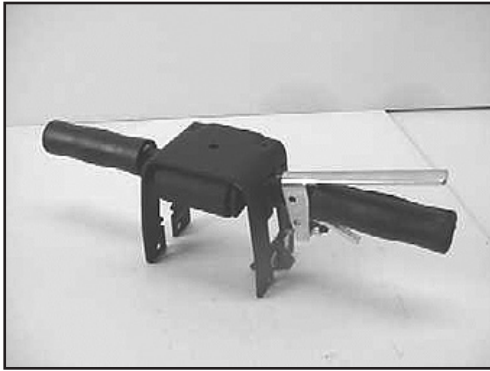

1. Loosen the screws to remove the top cover.

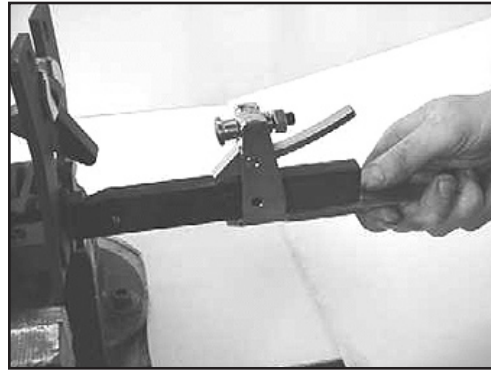

4. Remove the trigger lever.

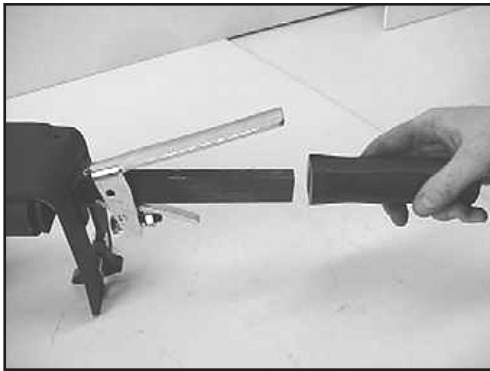

2. Remove the rubber handles.

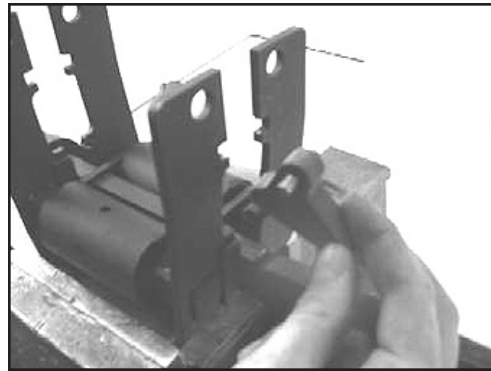

5. Remove and replace the trigger pawl, if necessary.

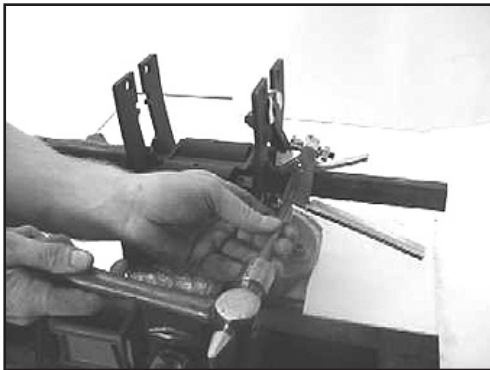

3. Hammer out the roll pin.

## Assembly

Refer to the illustrations and parts lists for the correct orientation and placement of parts.

Replace any O-rings, V-rings, seals, and gaskets on parts that have been disassembled. Apply hydraulic fluid or O-ring lubricant to all O-rings and all metal surfaces which they must slide over. When installing

an O-ring which must slide over sharp surfaces, use a rolling motion and be careful not to damage the O-ring.

Wherever the assembly results in metal-to-metal contact, coat the surfaces with hydraulic fluid or O-ring lubricant.

## Assembly of Valve Housing

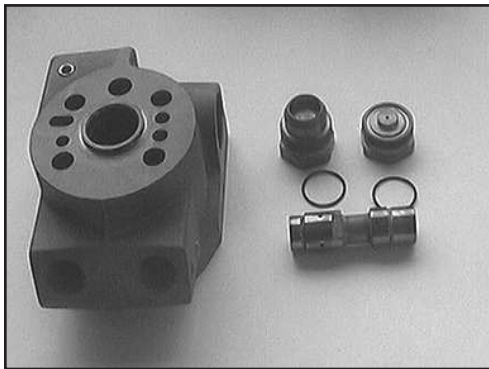

1. Use these parts.

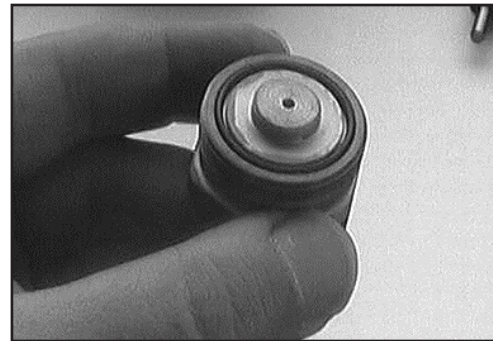

4. Grease and mount the O-ring on the P guide socket.

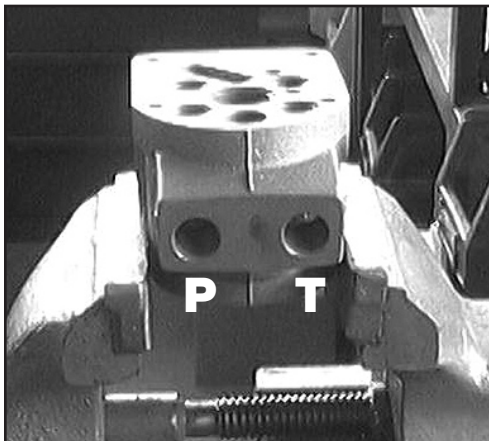

2. Locate P and T (marked on housing).



5. Grease and mount the O-ring on the T guide socket.

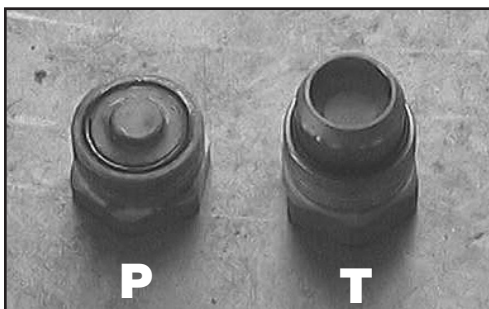

3. Identify the P and T guide sockets.

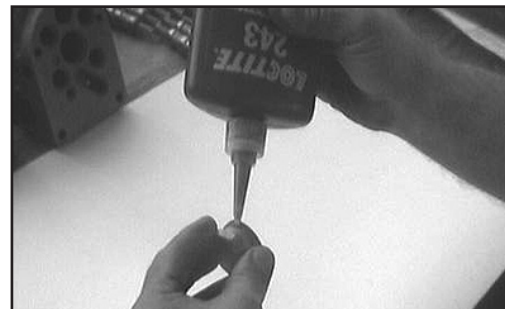

6. Apply Loctite 243 (245) to the P socket thread.

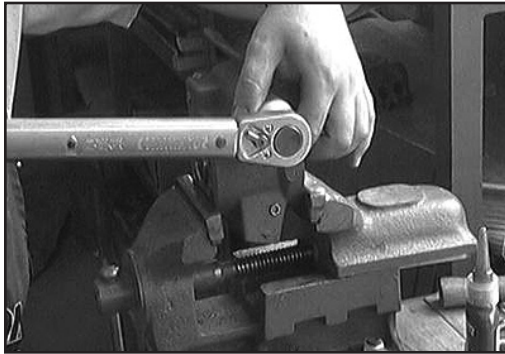
**Assembly of Valve Housing (cont'd)**

7. Mount the P socket at the P side and torque to 100 Nm (74 ft-lb).

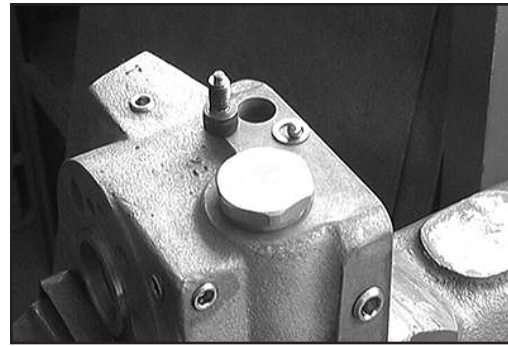

11. Mount the ball, seal ring, and screw.

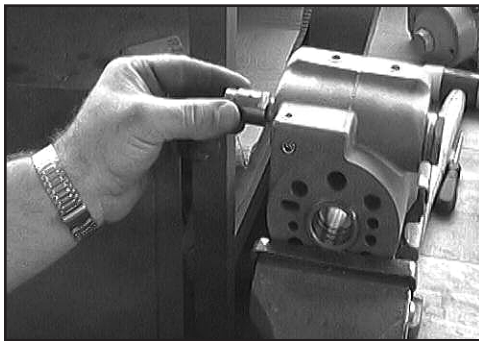

8. Mount the spool at the T side (note the milling).

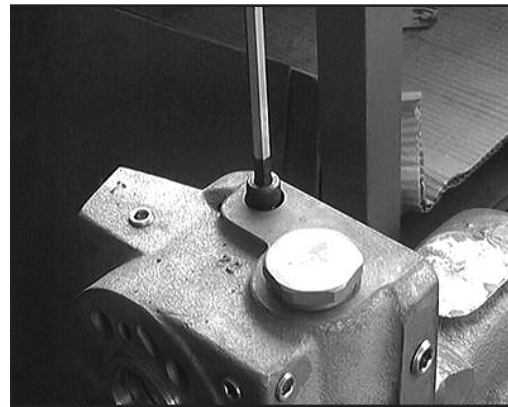

12. Tighten the screw with a hex socket wrench.



9. Apply Loctite 243 (245) to the T socket thread.



13. Check the movement of the spool by shaking it from side to side.

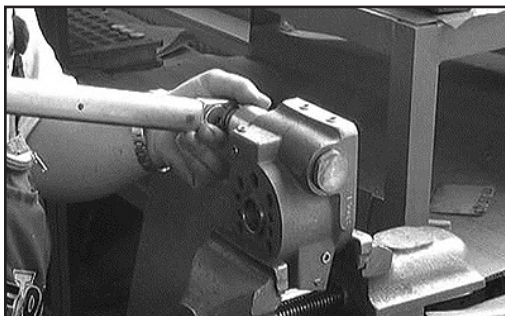

10. Mount the T socket at the T side and torque to 100 Nm (74 ft-lb).

### Assembly of Cylinder



1. Use these parts.



4. Mount the seal on a punch ( $\varnothing 37$  mm).



2. Mount the seal (green).



5. Mount the seal with an engineer's hammer.



3. Mount the backup washer and locking ring.



6. Mount the locking ring.

**Assembly of Accumulator**



1. Use these parts.



5. Mount the cover in the body.



2. Mount the diaphragm.



6. Tighten the cover with a hook wrench to 200 Nm (148 ft-lb).



3. Oil the diaphragm.



7. Mount the charging screw and seal ring.

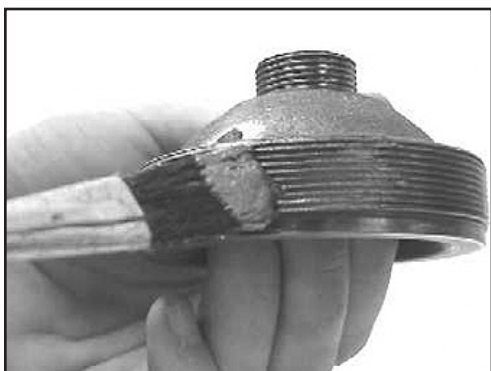

4. Grease the cover with copper grease.

### Assembly of Main Components



1. Oil the seals in the cylinder.

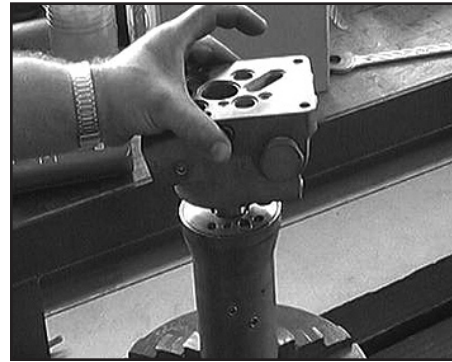

5. Mount the valve housing.

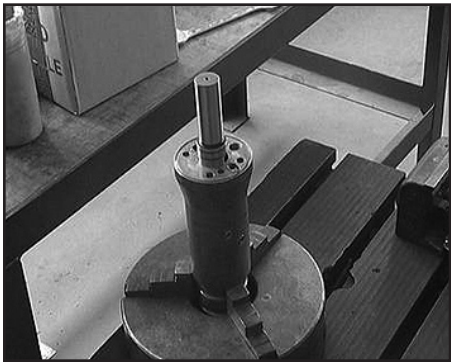

2. Mount the striking piston in the cylinder.

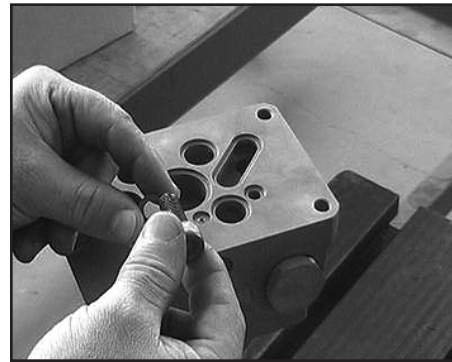

6. Mount the screws in the valve housing.

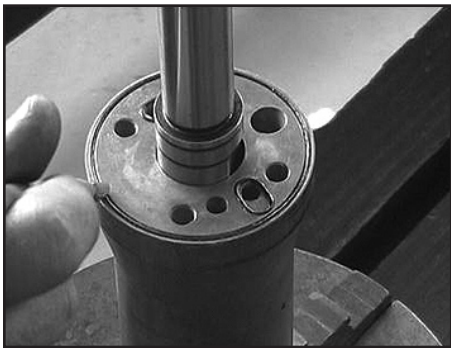

3. Grease the O-ring grooves on the cylinder and mount the O-rings.

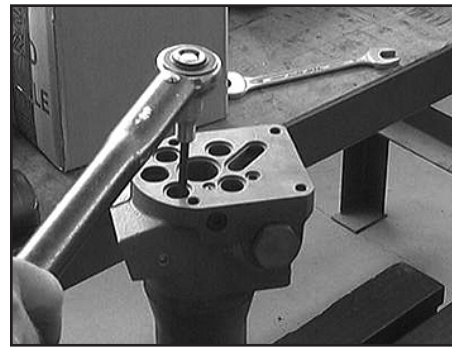

7. Tighten the screws in the valve housing and torque to 80 Nm (59 ft-lb).



4. Apply Loctite 243 (245) to the cylinder thread.

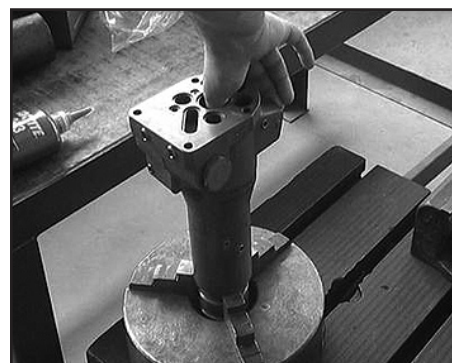

8. Check the movement of the piston in the valve housing.

**Assembly of Main Components (cont'd)**



9. Check the movement of the striking piston.

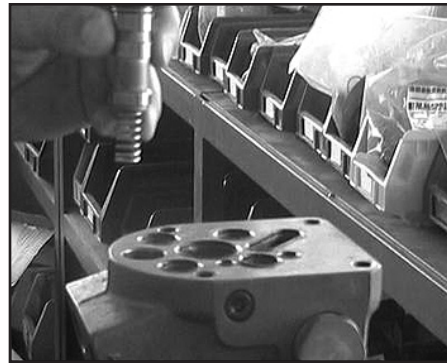

13. Mount the trigger valve.

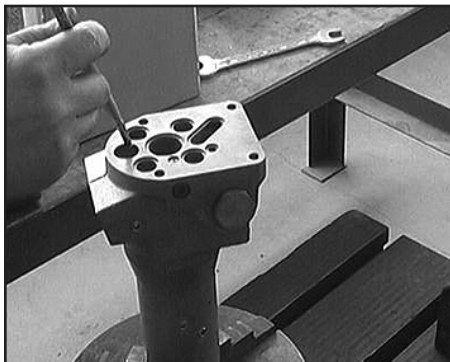

10. Grease the O-ring grooves in the valve housing.

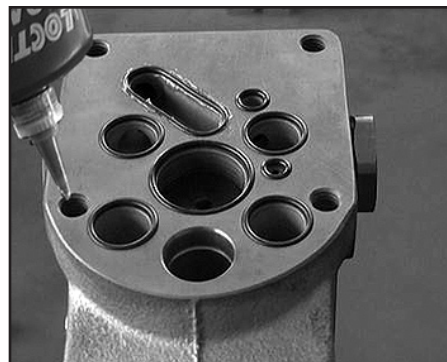

14. Apply Loctite 245 to the valve housing.

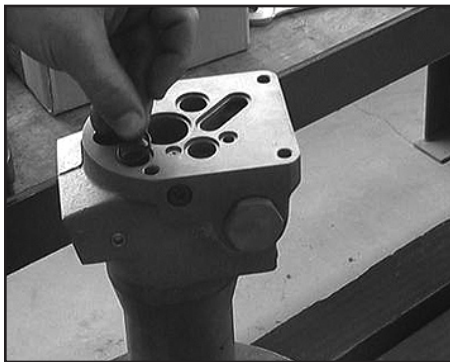

11. Mount the O-rings.



15. Mount the accumulator.

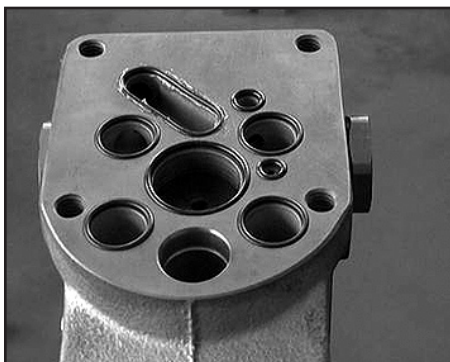

12. O-rings mounted.

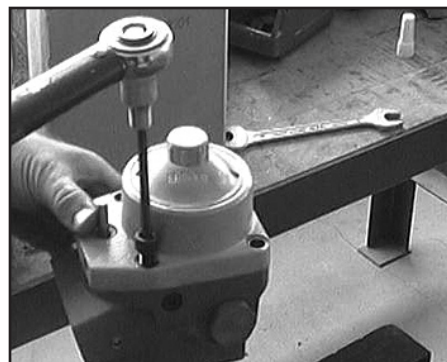

16. Tighten the screws on the accumulator and torque to 70 Nm (52 ft-lb).



**Assembly of Main Components (cont'd)**

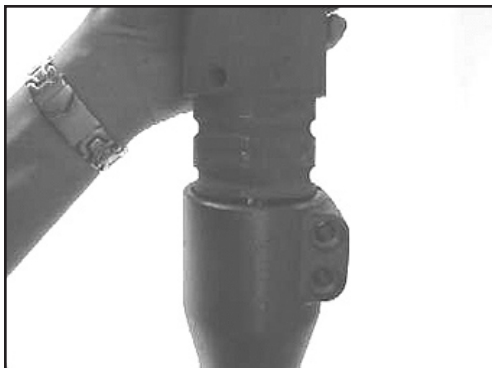

17. Mount the nose part.

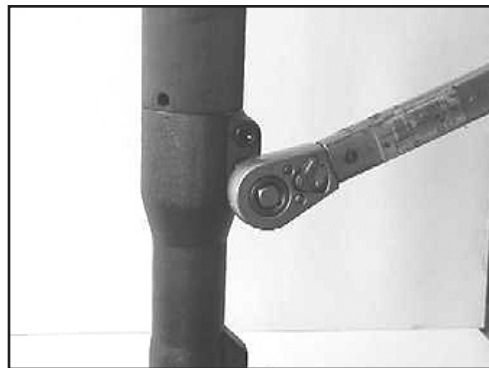

19. Mount the screws on the nose part and torque to:  
60 Nm (45 ft-lb) for HPB45 and HPB55  
100 Nm (74 ft-lb) for HPB75



18. Apply Loctite 245 to the screws.

**Mounting of Bushing in Nose Part**

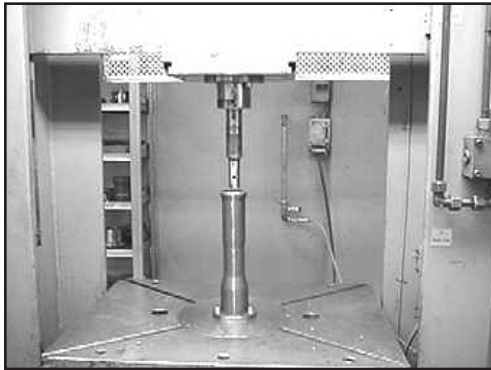

1. Mount the nose part in a hydraulic press designed for min. 10 t.



4. Apply Loctite 648 to the bushing.

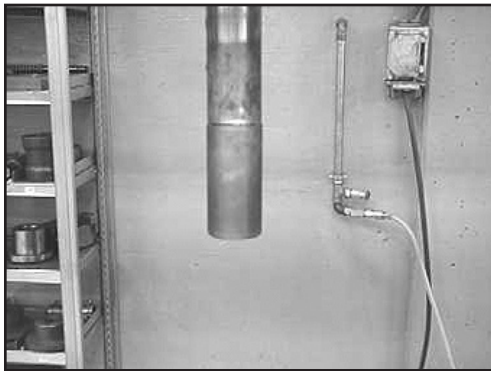

2. Mount the bushing in a suitable pin.

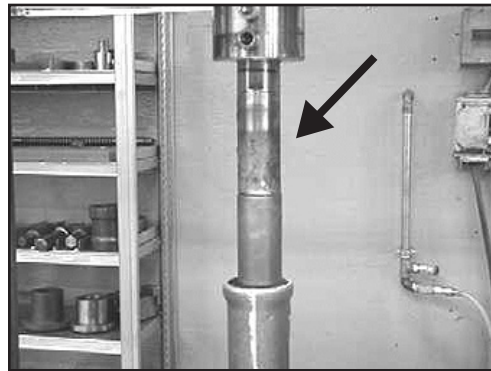

5. Check the length of the bushing and mark it.



3. Place the nose part.



6. Press the bushing into the nose part with a pressure of 10 t.

**Mounting of Latch in Nose Part**

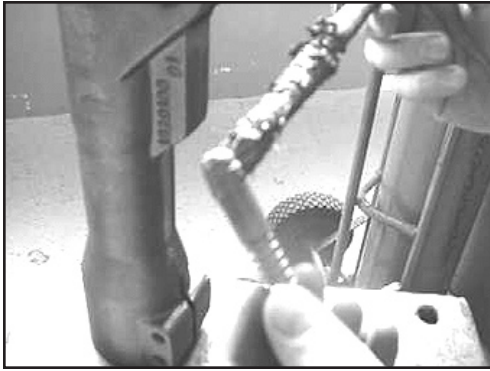

1. Grease the lock pin and spring with copper grease.

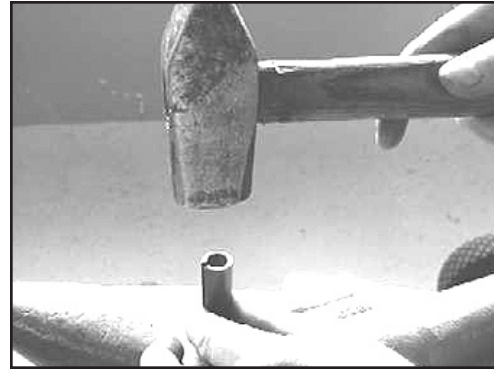

5. Hammer the bigger roll pin with the opening against the bottom of the nose part.

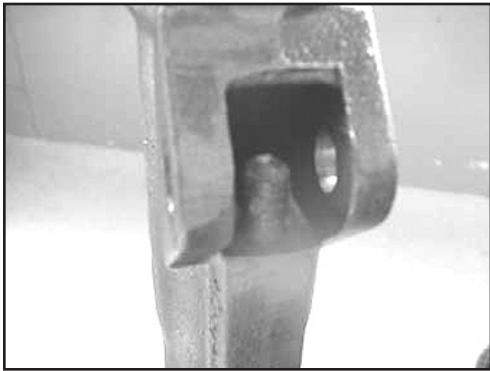

2. Mount the lock pin and spring in the nose part.

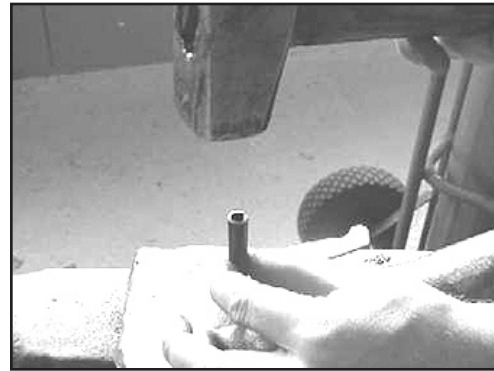

6. Mount the smaller roll pin opposite the bigger one.



3. Place the latch.



7. Check that it looks like this.



4. Place the nose part on an anvil.



8. Check the latch to make sure it moves.

### Adjustment of Dampening Handle



1. Mount the handle on the breaker.

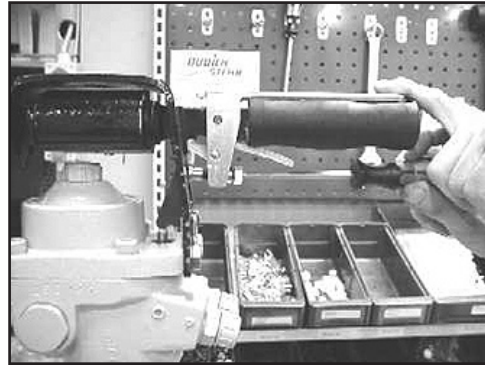

3. Adjust the trigger pawl to an additional travel clearance of 1 mm to 2 mm (0.04" to 0.08") from the adjusting screw.

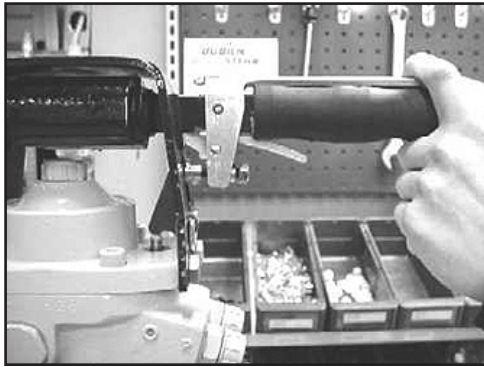

2. Activate the trigger lever.

**Main Illustration—All Models**

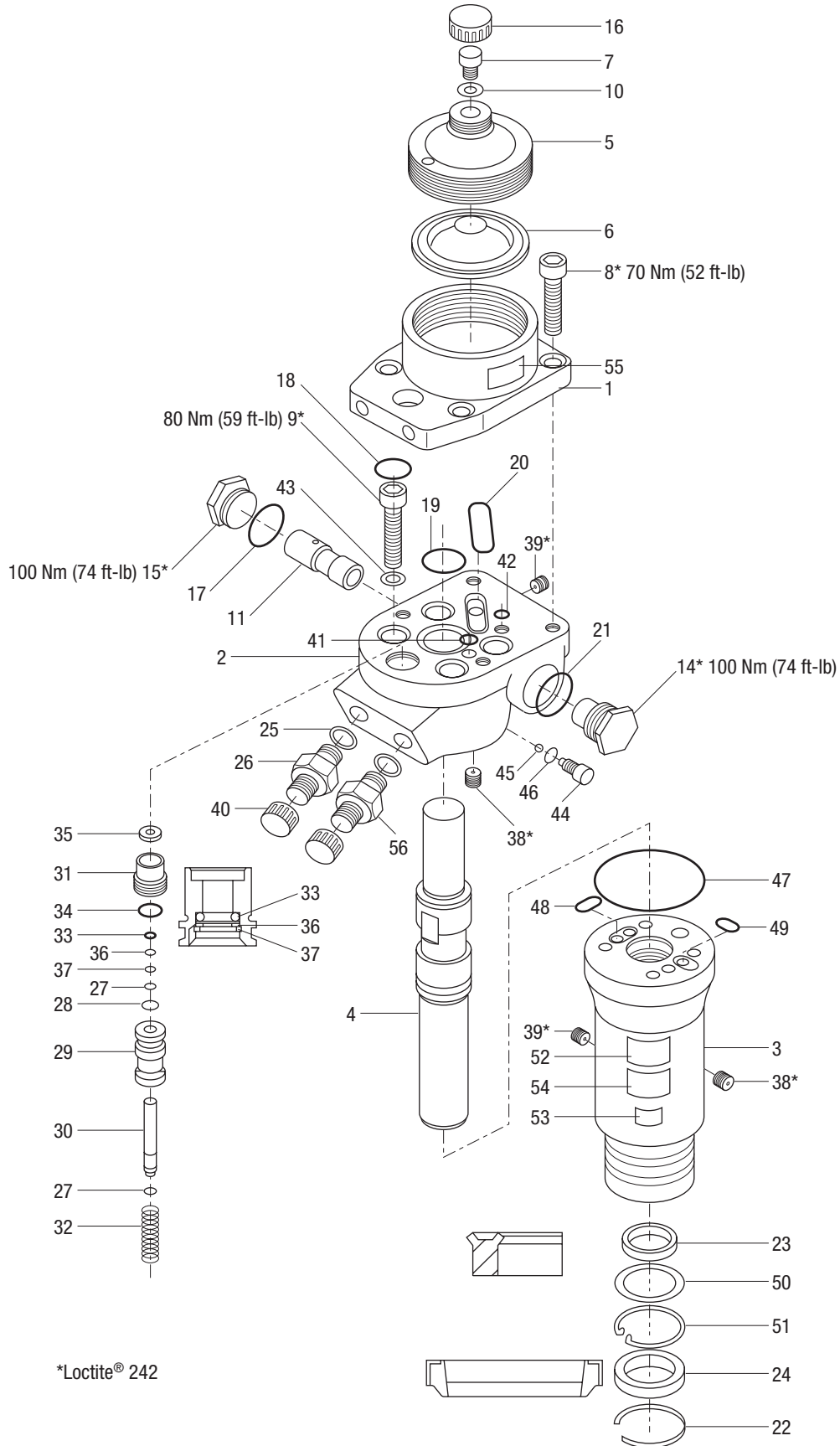

**Main Parts List—HPB45 and HPB55**

Key	Part No.	Description	Qty	Key	Part No.	Description	Qty
1	50022083	Accumulator body.....	1	33	50022490	O-ring, Ø8.3x2.4.....	1
2	50022130	Valve housing.....	1	34	50022512	O-ring, Ø16.3x2.4.....	1
3	50022148	Cylinder (HPB45).....	1	35	50022520	Seal, Ø8/Ø14x3.5/5.....	1
	50024027	Cylinder (HPB55).....	1	36	50022539	Backup ring.....	1
4	50022156	Striking piston (HPB45).....	1	37	50022547	Seeger spring ring.....	1
	50024035	Striking piston (HPB55).....	1	38	50022555	Fitting, 02 KRG.....	6
5	50022164	Accumulator cover.....	1	39	50022563	Fitting, 04 KRG.....	3
6	50022172	Diaphragm.....	1	40	50022741	Protective cap, 1/2" BSP.....	2
7	50022180	Charging screw.....	1	41	50022768	O-ring, Ø6x2.....	1
8	50022199	Screw, M10x30.....	4	42	50022784	O-ring, Ø8x2.....	1
9	50022202	Screw, M10x35.....	4	43	50022814	Backup washer.....	4
10	50022210	Seal ring, Ø8.7/Ø13x1.....	1	44	50022822	Screw.....	1
11	50022229	Spool.....	1	45	50022830	Check valve ball.....	1
14	50022253	Guide socket.....	1	46	50022849	Seal ring, Ø9/Ø14x1.....	1
15	50022261	Spool socket.....	1	47	50022857	O-ring, Ø82x1.5.....	1
16	50022270	Protective cap, M24x1.5.....	1	48	50022881	O-ring, Ø16x1.5.....	1
17	50022288	O-ring, Ø24x1.5.....	1	49	50022890	O-ring, Ø13x1.5.....	1
18	50022296	O-ring, Ø18x2.....	4	50	50022962	Backup washer, Ø32.7/45x2.5.....	1
19	50022300	O-ring, Ø30x2.....	1	51	50023063	Locking ring.....	1
20	50022318	O-ring, Ø32x2.....	1	52	50109499	Plate, identification.....	1
21	50022326	O-ring, Ø25x1.5.....	1	53	50109529	Decal, sound level 110 dB (HPB45-1).....	1
22	50022334	Locking ring.....	1		50027204	Decal, sound level 109 dB (HPB45-2).....	1
23	50022342	Seal, Ø32/Ø40x6.....	1		50109537	Decal, sound level 112 dB (HPB55).....	1
24	50022350	Seal, Ø32/Ø45x7/10.....	1	54	50110292	Decal, weight (HPB45-1).....	1
25	50022369	Seal ring, 1/2".....	2		50110284	Decal, weight (HPB45-2).....	1
26	50022377	Connector, 1/2" BSP.....	2		50110306	Decal, weight (HPB55).....	1
27	50022385	Seeger spring ring.....	2	55	50110764	Decal, accumulator.....	1
28	50022407	Shim PS, 8x14x0.5.....	1		50023101	Seal kit (includes items 10, 16–25, 27, 28, 33–37, 41, 42, 46–51, and 68/91)	
29	50022415	Trigger spool.....	1		50023152	Trigger valve kit (includes items 27–37)	
30	50022431	Trigger rod.....	1		50109138	Whip hose.....	2
31	50022458	Packing gland.....	1				
32	50022474	Spring.....	1				

**Main Parts List—HPB75**

Key	Part No.	Description	Qty	Key	Part No.	Description	Qty
1	50022083	Accumulator body.....	1	33	50022490	O-ring, Ø8.3x2.4.....	1
2	50024060	Valve housing .....	1	34	50022512	O-ring, Ø16.3x2.4.....	1
3	50024230	Cylinder.....	1	35	50022520	Seal, Ø8/Ø14x3.5/5.....	1
4	50024400	Striking piston .....	1	36	50022539	Backup ring.....	1
5	50022164	Accumulator cover.....	1	37	50022547	Seeger spring ring.....	1
6	50022172	Diaphragm .....	1	38	50022555	Fitting, 02 KRG.....	6
7	50022180	Charging screw .....	1	39	50022563	Fitting, 04 KRG.....	3
8	50022199	Screw, M10x30 .....	4	40	50022741	Protective cap, 1/2" BSP.....	2
9	50022202	Screw, M10x35 .....	4	41	50022768	O-ring, Ø6x2.....	1
10	50022210	Seal ring, Ø8.7/Ø13x1.....	1	42	50022784	O-ring, Ø8x2.....	1
11	50024710	Spool.....	1	43	50022814	Backup washer.....	4
14	50022253	Guide socket.....	1	44	50026755	Screw.....	1
15	50022261	Spool socket.....	1	45	50022830	Check valve ball .....	1
16	50022270	Protective cap, M24x1.5 .....	1	46	50022849	Seal ring, Ø9/Ø14x1.....	1
17	50022288	O-ring, Ø24x1.5.....	1	47	50022857	O-ring, Ø82x1.5.....	1
18	50022296	O-ring, Ø18x2.....	4	48	50026763	O-ring, Ø18x1.5.....	1
19	50022318	O-ring, Ø32x2.....	1	49	50022890	O-ring, Ø13x1.5.....	1
21	50022326	O-ring, Ø25x1.5.....	1	50	50027026	Backup washer, Ø38.7/Ø48x2.5.....	1
22	50025821	Locking ring .....	1	51	50027034	Locking ring .....	1
23	50025830	Seal, Ø38/Ø45x6 .....	1	52	50109499	Plate, identification .....	1
24	50026739	Seal, Ø38/Ø48x7/10 .....	1	53	50109545	Decal, sound level 113 dB .....	1
25	50022369	Seal ring, 1/2" .....	2	54	50110314	Decal, weight.....	1
26	50022377	Connector, 1/2" BSP .....	1	55	50110764	Decal, accumulator.....	1
27	50022385	Seeger spring ring .....	2	56	50027190	Connector, 1/2" BSP Ø5.2.....	1
28	50022407	Shim PS, 8x14x0.5 .....	1		50027042	Seal kit (includes items 10, 16–18, 20–25, 27, 28, 33–37, 41, 42, 46–51, and 68/91)	
29	50022415	Trigger spool.....	1		50023152	Trigger valve kit (includes items 27–37)	
30	50022431	Trigger rod.....	1		50109138	Whip hose .....	2
31	50022458	Packing gland.....	1				
32	50022474	Spring .....	1				

**Standard Handle with Cover  
Illustration and Parts List—All Models**

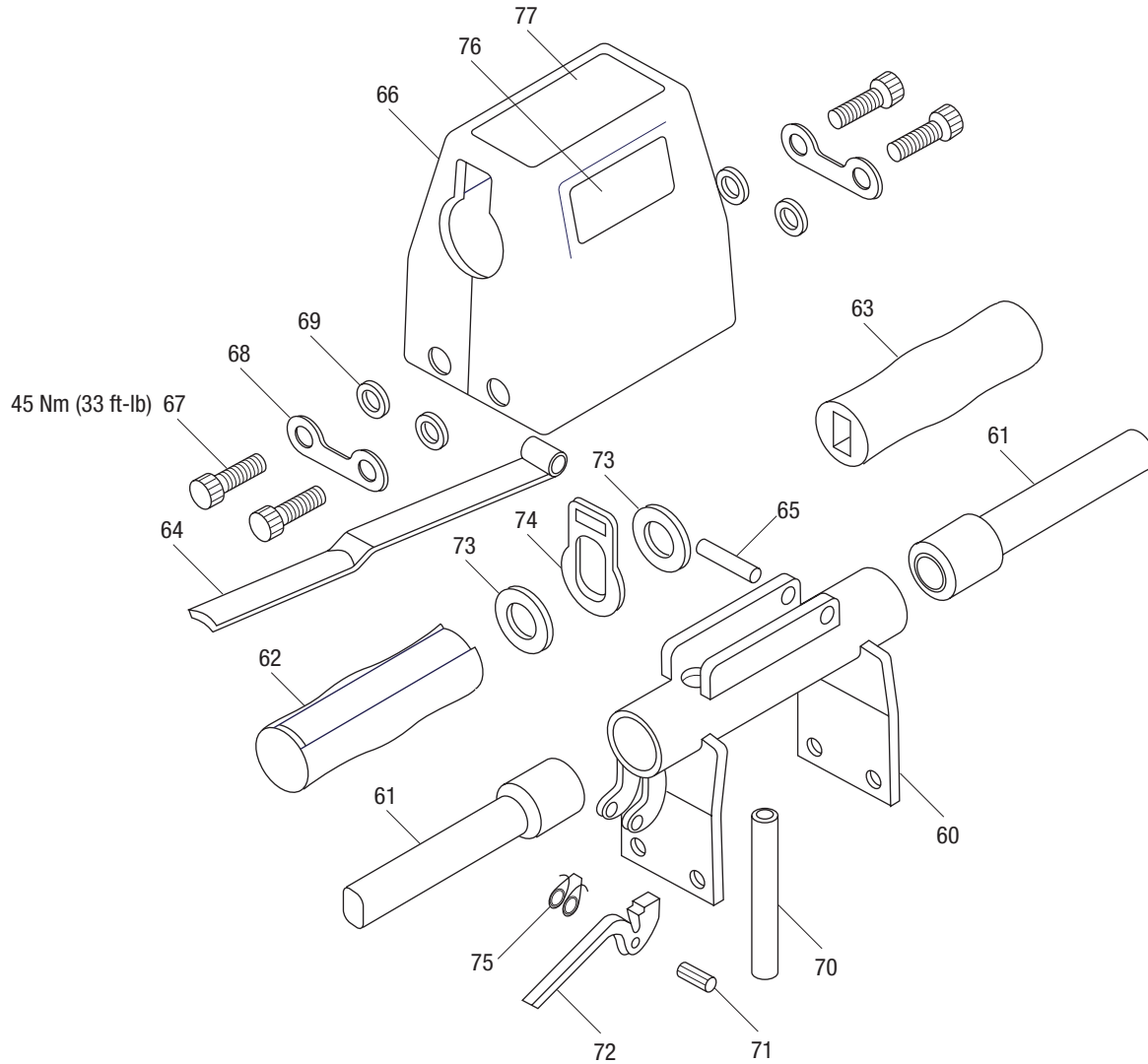

Key	Part No.	Description	Qty	Key	Part No.	Description	Qty
	50023179	Standard handle with cover		68	50023292	Nab .....	2
60	50023187	Bracket, standard handle .....	1	69	50023314	Handle spacer .....	4
61	50023195	Handle, standard .....	2	70	50023330	Nylon guide .....	1
62	50023209	Rubber handle .....	1	71	50023365	Slotted pin, Ø6x22 .....	1
63	50023217	Rubber handle .....	1	72	50023373	Safety trigger .....	1
64	50023241	Trigger lever, standard .....	1	73	50023381	Washer, nylon Ø21/Ø37x3 .....	2
65	50023250	Roll pin, Ø8x40 .....	1	74	50023390	Lock plate .....	1
66	50023268	Top cover .....	1	75	50023403	Spring .....	1
67	50023276	Screw, M10x20 .....	4	76	50463268	Decal, Fairmont .....	2
				77	49009	Decal, warning .....	1



**Dampening Handle with Cover  
Illustration and Parts List—All Models**

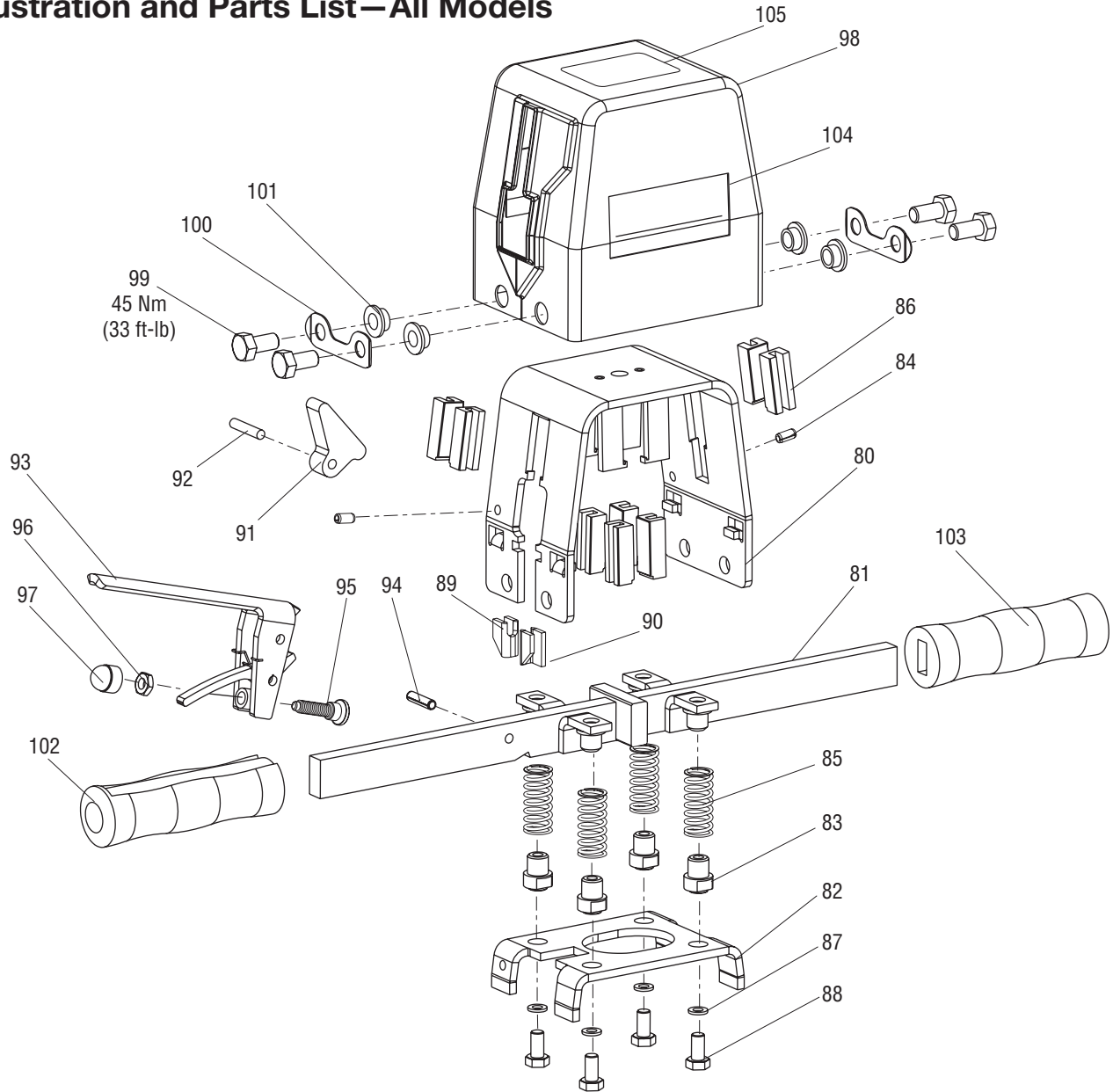

Key	Part No.	Description	Qty	Key	Part No.	Description	Qty
	52020091	Dampening handle with cover		92	50023527	Pin, pawl Ø6x30	1
80	52020092	Frame	1	93	50023446	Trigger lever	1
81	52020093	Handle rod	1	94	50023535	Roll pin, Ø6x24	1
82	52020094	Bottom plate	1	95	50023560	Thrust pad with screw	1
83	52020095	Spring guide	4	96	50023578	Nut, M8	1
84	52020096	Roll pin, Ø6x12	2	97	50023586	Nut, cap, M8-hex 13 black	1
85	52020097	Spring	4	98	50023543	Top cover	1
86	52020098	Nylon guide	8	99	50023276	Screw, M10x20	4
87	52020099	Washer, Ø8	4	100	50023292	Nab	2
88	52020100	Screw, M8x16	4	101	50023314	Handle spacer	4
89	50023497	Pin latch, right	1	102	50023209	Rubber handle	1
90	50023500	Pin latch, left	1	103	50023217	Rubber handle	1
91	50023470	Trigger pawl	1	104	50463268	Decal, Fairmont	2
				105	49009	Decal, warning	1

**Nose Part Illustration and Parts Lists**

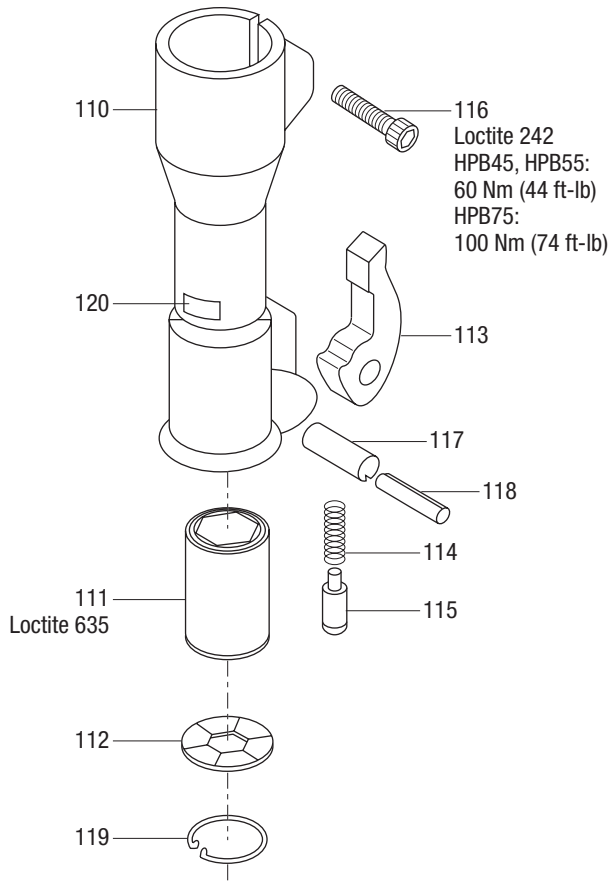

**HPB55**

Key	Part No.	Description	Qty
<b>1-1/8" x 6" Hex Shank</b>			
110	50023837	Nose part, hex 1-1/8", 1-1/4"	1
111	50023918	Bushing, hex 1-1/8" x 6"	1
112	50023926	Chisel bellows, hex 1-1/8"	1
113	50023705	Latch	1
114	50023730	Spring	1
115	50023748	Lock pin	1
116	50023756	Screw, M10x55	2
117	50023764	Roll pin, Ø16x50	1
118	50023802	Roll pin, Ø10x50	1
119	50023934	Locking ring, 64x2	1
120	50109561	Decal, hex shank size 1-1/8 x 6	1

**1-1/4" x 6" Hex Shank**

110	50023837	Nose part, hex 1-1/8", 1-1/4"	1
111	50023942	Bushing, hex 1-1/4" x 6"	1
112	50023969	Chisel bellows, hex 1-1/4"	1
113	50023705	Latch	1
114	50023730	Spring	1
115	50023748	Lock pin	1
116	50023756	Screw, M10x55	2
117	50023764	Roll pin, Ø16x50	1
118	50023802	Roll pin, Ø10x50	1

**HPB45**

Key	Part No.	Description	Qty
<b>1" x 4-1/4" Hex Shank</b>			
110	50023624	Nose part, hex 1"	1
111	50023632	Bushing, hex 1" x 4-1/4"	1
112	50023675	Chisel bellows, hex 1"	1
113	50023705	Latch	1
114	50023730	Spring	1
115	50023748	Lock pin	1
116	50023756	Screw, M10x55	2
117	50023764	Roll pin, Ø16x50	1
118	50023802	Roll pin, Ø10x50	1
119	50023829	Locking ring, 57x2	1
120	50109570	Decal, hex shank size 1 x 4-1/4	1

**1-1/8" x 6" Hex Shank**

110	50023837	Nose part, hex 1-1/8", 1-1/4"	1
111	50023918	Bushing, hex 1-1/8" x 6"	1
112	50023926	Chisel bellows, hex 1-1/8"	1
113	50023705	Latch	1
114	50023730	Spring	1
115	50023748	Lock pin	1
116	50023756	Screw, M10x55	2
117	50023764	Roll pin, Ø16x50	1
118	50023802	Roll pin, Ø10x50	1

**HPB75**

Key	Part No.	Description	Qty
<b>1-1/8" x 6" Hex Shank</b>			
110	50027050	Nose part, hex	1
111	50023918	Bushing, hex 1-1/8" x 6"	1
112	50023926	Chisel bellows, hex 1-1/8"	1
113	50023705	Latch	1
114	50023730	Spring	1
115	50023748	Lock pin	1
116	50027093	Screw, M12x75	2
117	50027123	Roll pin, Ø16x60	1
118	50027131	Roll pin, Ø10x60	1
119	50023934	Locking ring, 64x2	1
120	50109561	Decal, hex shank size 1-1/8 x 6	1

**1-1/4" x 6" Hex Shank**

110	50027050	Nose part, hex	1
111	50023942	Bushing, hex 1-1/4" x 6"	1
112	50023969	Chisel bellows, hex 1-1/4"	1
113	50023705	Latch	1
114	50023730	Spring	1
115	50023748	Lock pin	1
116	50027093	Screw, M12x75	2
117	50027123	Roll pin, Ø16x60	1
118	50027131	Roll pin, Ø10x60	1





**GREENLEE®**

A Textron Company

USA	800-435-0786	Fax: 800-451-2632
	815-397-7070	Fax: 815-397-1865
Canada	800-435-0786	Fax: 800-524-2853
International	+1-815-397-7070	Fax: +1-815-397-9247

4455 Boeing Drive • Rockford, IL 61109-2988 • USA • 815-397-7070  
An ISO 9001 Company • Greenlee Textron Inc. is a subsidiary of Textron Inc.

[www.greenlee.com](http://www.greenlee.com)