

INSTRUCTION MANUAL

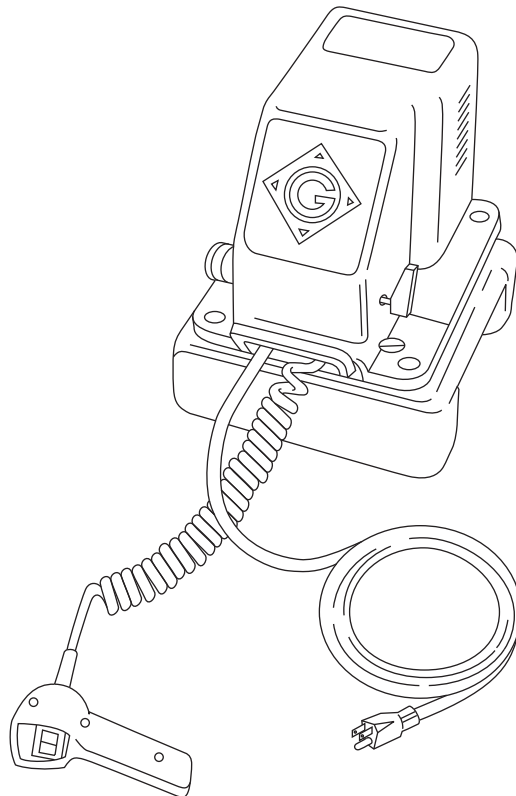

975 Hydraulic Power Pump

Serial Code TZ



Read and understand all of the instructions and safety information in this manual before operating or servicing this tool.

Register this product at www.greenlee.com

Table of Contents

Description	2
Safety	2
Purpose of this Manual	2
Important Safety Information	3-4
Specifications	5
Setup	
Hydraulic Connection	6
Electrical Connection/Grounding Instructions	6
Operation	7
Maintenance	8-9
Troubleshooting	10-15
Service	16-18
Repairs	19-21
Exploded Views	22-23
Parts List	24-26

Description

Greenlee 975 Hydraulic Power Pump is an electrically powered two-stage pump that develops a maximum of 700 bar (10,000 psi). This pump is intended to provide hydraulic power for an accessory with a single-acting ram such as a Greenlee conduit bender or cable cutter. This pump has a factory-set internal pressure relief valve.

	⚠ CAUTION
	<p>Fill unit with hydraulic oil before operating pump.</p> <p>Failure to fill unit with oil will result in damage to the pump</p>

Safety

Safety is essential in the use and maintenance of Greenlee tools and equipment. This instruction manual and any markings on the tool provide information for avoiding hazards and unsafe practices related to the use of this tool. Observe all of the safety information provided.

Purpose of this Manual

This manual is intended to familiarize all personnel with the safe operation and maintenance procedures for the following Greenlee 975 (Serial Code TZ).

Keep this manual available to all personnel.

Replacement manuals are available upon request at no charge at www.greenlee.com.

All specifications are nominal and may change as design improvements occur. Greenlee Textron Inc. shall not be liable for damages resulting from misapplication or misuse of its products.

732 is a trademark of Dow Corning.

Loctite and Ultra Blue are registered trademarks of Loctite Corporation.

Mobil DTE is a registered trademark of Mobil Oil Corporation.

KEEP THIS MANUAL

IMPORTANT SAFETY INFORMATION



SAFETY ALERT SYMBOL

This symbol is used to call your attention to hazards or unsafe practices which could result in an injury or property damage. The signal word, defined below, indicates the severity of the hazard. The message after the signal word provides information for preventing or avoiding the hazard.

⚠ DANGER

Immediate hazards which, if not avoided, **WILL** result in severe injury or death.

⚠ WARNING

Hazards which, if not avoided, **COULD** result in severe injury or death.

⚠ CAUTION

Hazards or unsafe practices which, if not avoided, **MAY** result in injury or property damage.

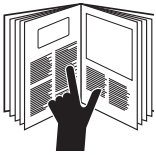

⚠ DANGER

Read and understand all of the instructions and safety information in this manual before operating or servicing this tool.

Failure to observe this warning will result in severe injury or death.

⚠ DANGER

Do not connect the pump to any system or system component other than those supplied by Greenlee. Other manufacturer's components may not withstand the maximum pressure and may fail. Nearby personnel can be injured by flying components and hydraulic oil.

Failure to observe this warning will result in severe injury or death.

⚠ DANGER

Do not alter the internal high-pressure relief valve setting. Altering this setting will change the maximum pressure the pump can develop, which can cause a component failure. Nearby personnel can be injured by flying components and hydraulic oil.

Failure to observe this warning will result in severe injury or death.





⚠ DANGER

Do not use this pump in a hazardous environment. Hazards include flammable liquids, gases, or other materials. Using this pump in a hazardous environment can result in a fire or explosion.

Failure to observe these warnings will result in severe injury or death.

IMPORTANT SAFETY INFORMATION

	<p style="text-align: center;">⚠ WARNING</p> <p>Electric shock hazard:</p> <ul style="list-style-type: none"> • Do not expose power tools to rain. • Do not immerse the pendant switch in water or other liquid. <p>Failure to observe these warnings can result in severe injury or death.</p>
---	--

	<p style="text-align: center;">⚠ CAUTION</p> <p>Fill unit with hydraulic oil before operating pump.</p> <p>Failure to fill unit with oil will result in damage to the pump</p>
---	---

	<p style="text-align: center;">⚠ WARNING</p> <p>Skin injection hazard:</p> <p>High pressure oil easily punctures skin causing serious injury, gangrene, or death. If injured, seek medical help immediately to remove oil.</p> <ul style="list-style-type: none"> • Do not use fingers or hands to check for leaks. • Depressurize hydraulic system before servicing or disconnecting the hose.
---	--

<p style="margin: 0;">⚠ CAUTION</p>
<ul style="list-style-type: none"> • The pump is heavy and requires two persons to lift. Improper lifting can result in injury. • Do not use hose or cord to pull, lift, or carry the equipment. Misuse will damage the hose or cord. <p>Failure to observe these precautions can result in injury or property damage.</p>

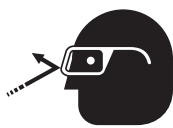
	<p style="text-align: center;">⚠ WARNING</p> <p>Wear eye protection when using this tool.</p> <p>Failure to wear eye protection can result in serious eye injury from flying debris or hydraulic oil.</p>
---	--

<p style="margin: 0;">IMPORTANT</p>
<p>Make sure all hose fittings are properly seated before starting the pump. Incomplete connections may not allow the accessory's ram to retract after the hydraulic operation is finished.</p>

Note: Keep all decals clean and legible, and replace when necessary.

<p style="margin: 0;">⚠ WARNING</p>
<p>Inspect pump, hoses, couplers, and fittings for wear or damage. Replace worn, damaged or missing components with Greenlee replacement parts. Worn or damaged components can fail, resulting in injury.</p> <p>Failure to observe this warning can result in severe injury or death.</p>

Setup

Hydraulic Connection

1. Clean all couplers, threaded fittings, ports and the area around all ports.
2. Remove any dust plugs from couplers.
3. Hand-tighten all couplings firmly (until all threads are fully engaged). Do not use tools.

Electrical Connection

	<p>⚠ WARNING</p>
	<p>Electric shock hazard:</p> <ul style="list-style-type: none"> • Do not modify the plug provided with the tool. • Connect this tool to a grounded receptacle on a 15-amp GFCI-protected circuit. <p>Failure to observe these warnings can result in severe injury or death.</p>

This tool must be grounded. In the event of a malfunction or breakdown, an electrical ground provides a path of least resistance for the electric current. This path of least resistance is intended to reduce the risk of electric shock.

This tool's electric cord has a grounding conductor and a grounding plug as shown. Do not modify the plug. Connect the plug to a corresponding 15-amp GFCI-protected receptacle that is properly installed and grounded in accordance with all national and local codes and ordinances. Do not use an adapter.

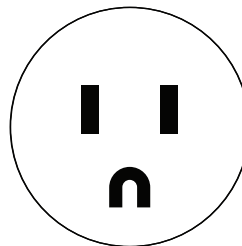

Plug

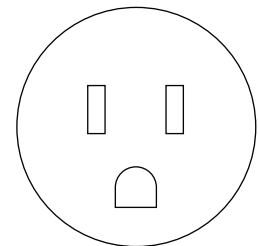

Receptacle

Extension Cord Specifications:

- Diameter 1.5 mm² (14 AWG)
- Length..... 30 meters (100 feet)

Use only three-wire extension cords. Use of an inadequate extension cord will cause the motor to stall.

Operation

	⚠ WARNING
	<p>Skin injection hazard: High pressure oil easily punctures skin causing serious injury, gangrene, or death. If injured, seek medical help immediately to remove oil.</p> <ul style="list-style-type: none"> • Do not use fingers or hands to check for leaks. • Depressurize hydraulic system before servicing or disconnecting the hose.

IMPORTANT
<p>Procedure for depressurizing the hydraulic system:</p> <ol style="list-style-type: none"> 1. Disconnect the pump from the power source. 2. Rotate the release lever to AUTO RELEASE and allow the ram to retract fully. 3. Disconnect the hose slowly to release any trapped pressure.

Note: To prevent leakage, this pump was shipped with an unvented plug installed in the reservoir fill hole. This plug must be replaced with the attached vented plug (6) before use. Failure to replace the unvented plug will cause poor performance.

Note: Starting the motor without a tool attached to the pump will cause the pump to immediately build an internal pressure of 700 bar (10,000 psi). If this happens, shut off the pump and turn the release valve to AUTO RELEASE to release the hydraulic pressure.

1. Move release valve lever to the AUTO RELEASE position.
2. Check reservoir oil level. The oil level should be within 25 mm (1 inch) of the top of the reservoir. If oil level is too low, see Adding Oil in the Maintenance section for instructions.
3. Place release valve lever in desired position:
 - AUTO RELEASE – ram will stop and then retract when the hand switch or foot switch is released.
 - MANUAL RELEASE – ram will stop but will not retract when the hand switch or foot switch is released.
4. Press the hand switch or foot switch to advance the hydraulic ram. When finished, release the hand switch or foot switch.

Note: If release valve lever is in the MANUAL RELEASE position, the ram will not retract. To retract ram, rotate the release valve lever to the AUTO RELEASE position.

Maintenance

IMPORTANT

Procedure for depressurizing the hydraulic system:

1. Disconnect the pump from the power source.
2. Rotate the release lever to AUTO RELEASE and allow the ram to retract fully.
3. Disconnect the hose slowly to release any trapped pressure.

Every time the pump is used

- Check the oil reservoir level. The oil level should be approximately 25 mm (1 inch) from the top of the reservoir. If the oil level is low, see Adding Oil.
- Examine the condition of the hose, connectors, and O-rings for deterioration, wear, or other damage. Replace any missing or damaged components.
- Check the condition of all electrical cords, plugs, and connectors.
- Listen for unusual noises and observe the operation of the pump for changes in performance. Either situation may indicate that maintenance or repairs are necessary.

Periodically

- Examine the hydraulic oil for changes in color or viscosity, and the presence of dirt or other contamination.
- Occasionally check oil temperature after pump is operated. The recommended operating temperature is 38 °C to 50 °C (100 °F to 125 °F).

Cleaning

- Periodically clean the exterior of the pump and motor. Use a vacuum cleaner to clean the ventilation openings.
- Clean the area around the reservoir vent, and be sure the vent breather hole is open.
- Keep all hose connections clean and use protective caps or plugs when couplers are not in use.

Oil Condition

Visual inspection of the oil may be used as a guide to determine the need to replace the oil. A change in appearance, such as darkening or thickening, will indicate a need for replacement. The continued use of oil after it should be replaced will cause accelerated wear of system components and will void the warranty.

Adding Oil

⚠ CAUTION

Do not use brake fluid. Brake fluid will ruin the seals.

1. Place control lever in AUTO RELEASE position.
2. Unplug the electrical cord from the power source.
3. Thoroughly clean the area around the fill hole.
4. Remove the vented reservoir plug.
5. Use Greenlee hydraulic fluid or an equivalent high-grade light hydraulic oil. See the “Parts List” section of this manual for Greenlee hydraulic oil specification and Greenlee part number.
6. Pour the oil through a clean funnel with filter screen.
7. Add oil until oil level is 25 mm (1 inch) from the top of the reservoir cover.

Maintenance (cont'd)

Purging (Bleeding) Air

⚠ CAUTION

When purging air from the system:

- Do not advance the ram more than 3/4 of its stroke. Overextending the ram will allow hydraulic fluid to leak out, and the ram may damage the O-rings when it retracts.
- Do not restrict the ram travel to run the pump up to full pressure (commonly called dead heading the pump).

Failure to observe these precautions can result in injury or property damage.

Erratic performance may indicate air in the hydraulic system.

1. Remove the ram from the accessory (conduit bender frame, cable cutter, etc.).
2. If possible, position the pump so that it is located higher than the ram. This will allow air to travel up the hydraulic hose to the pump reservoir.
3. Place the ram in a vertical position with the hose coupler upward.
4. Rotate the control lever counterclockwise (to MANUAL RELEASE).
5. Start the pump and, using the ram scale as a reference, advance the ram 3/4 of its stroke. Stop the pump. Do not overextend the ram!
6. Rotate the control lever clockwise (to AUTO RELEASE). The ram will retract, forcing any air out through the hose, into the pump reservoir, and through the vented plug.
7. Check the oil level of the reservoir. Add oil if necessary.

Draining and Flushing the System

Note: Thoroughly clean the pump exterior before removing the reservoir.

1. Remove the reservoir cover screws.
2. Remove the pump system from the reservoir.
Note: Be careful not to damage the cover gasket, inlet strainer or relief valve when removing the pump.
3. Clean the interior of the reservoir and fill with clean kerosene. Do not use solvents. Rinse the inlet strainer.
4. Place the pump system into the reservoir and replace the four cover screws.
5. Connect a hose to the pump as usual. Insert the other end of the hose into the pump reservoir at fill hole.
6. Run the pump for several minutes. While the pump is running, rotate the control lever between MANUAL RELEASE and AUTO RELEASE several times. Start and stop the pump several times to cycle the pilot-operated valve.
7. Remove the hose and remove the pump assembly from the reservoir. Drain and clean the reservoir interior. Allow the reservoir to dry. Drain the hose.
8. Reassemble the pump system.
9. Refill reservoir as instructed under the Adding Oil instructions in this section.

Motor Maintenance

Disconnect the pump from the power source before servicing or cleaning the motor. The exposed motor bearings and shaft should be cleaned periodically.

Lubrication

Lubricate the motor according to the motor manufacturer's instructions, which are on the nameplate or the terminal box cover.

Troubleshooting—Hydraulic Pump

Repair work must be done by qualified personnel familiar with this equipment.

If possible, use a hand pump to apply back pressure when checking for leaks.

How to use this table: If your hydraulic pump does not operate properly, find the description of the problem under the “Problem” column. Read the Probable Cause and the Probable Remedy. Begin with solution listed first, and proceed through all of the solutions until the problem is solved. Where repairs are necessary, see the appropriate schematic and item listed in the “Probable Remedy” column.

Problem	Probable Cause	Probable Remedy
Motor will not start.	No power to motor.	Plug electric cord in to a properly rated power source. Unplug cord and inspect the contacts. Clean contacts if necessary.
		Replace the electric cord.
		Replace switch cord or ON/OFF switch.
Motor will not start under load.	Motor is damaged or worn out.	Replace motor.
	Voltage supplied to motor is too low.	Unplug cord and check power source with a voltmeter. The voltage should be 120 VAC (+/- 10%).
	Current rating of extension cord is too low.	See the extension cord specifications under Electrical Connection in the Setup section of this manual.
Motor starts, but stops when it encounters a load.	Pilot-operated valve will not open, will not open fully, or opens too slowly.	See “Troubleshooting—Pilot-Operated Valve” at the end of this troubleshooting section.
	Voltage supplied to motor is too low.	Unplug cord and check power source with a voltmeter. The voltage should be 120 VAC (+/- 10%).
	Current rating of extension cord is too low.	See the extension cord specifications under Electrical Connection in the Setup section of this manual.
	Motor is overheated.	Let motor cool. Do not run motor continuously in a hot environment.
	Misalignment of the motor shaft and low pressure pump drive shaft.	Replace reservoir cover plate (22).
The counterweight needs adjustment.	The counterweight needs adjustment.	See Motor Face Seal, Figure A1, for the correct setting of the counterweight.
	Motor is damaged or worn out.	Replace motor.

Troubleshooting—Hydraulic Pump (cont'd)

Problem	Probable Cause	Probable Remedy
Ram will not advance. Ram advances slowly. Ram will not advance completely.	Low-pressure system has a partial or complete failure.	See Hydraulic Schematic (1,3,7) and refer to Figure A4 in the Repairs section of this manual.
	Unvented plug has not been replaced.	Remove the unvented plug and install the vented plug.
	Oil level is too low.	Add oil per instructions in the Maintenance and Service section of this manual.
	Wrong oil viscosity.	Replace oil with the type recommended in the Specifications section of this manual.
	Oil is dirty.	Replace oil with the type recommended in the Specifications section of this manual.
	Oil is cold.	Preheat oil. Without an accessory connected to the coupler, run the pump to build pressure, then release. Repeat until oil is warm.
	The intake strainer is dirty or clogged.	Remove the strainer and clean with kerosene.
	Motor rotates in the wrong direction.	Correct the motor wiring. See the Motor Control, Schematic Diagram in the Motor Control Unit section of this manual.
	Low-pressure relief valve is dirty or is set incorrectly.	To clean and adjust this valve, see Low-Pressure Relief Setting, Figure A4 in the Repairs section of this manual.
	Broken internal part.	Inspect and/or replace drive pin (78), motor shaft key (34), rollpin (39), or drive shaft (77).
	Worn or damaged internal part.	Inspect and/or replace the gerotor (80); eccentric shaft (38), or bearings (37 and/or 41).
	Pilot-operated valve will not close.	See “Troubleshooting—Pilot-Operated Valve” at the end of this troubleshooting section.
	Internal hydraulic fluid leak.	Inspect and replace as necessary: O-ring plug (79) and pump block cover (50).

Troubleshooting – Hydraulic Pump (cont'd)

Problem	Probable Cause	Probable Remedy
Ram advances erratically and retracts erratically.	Air in the hydraulic fluid.	Refer to Purging (Bleeding) Air in the Maintenance and Service section of this manual.
Pump will not build enough pressure to complete the job. Ram advances slowly.	High-pressure system is faulty.	See Hydraulic Schematic (5) and refer to Figure A5-1 in the Repairs section of this manual.
	System has an external hydraulic leak.	Visually inspect hoses, connectors and fittings for leaking hydraulic fluid. Replace faulty components.
	Pilot-operated valve will not close.	See “Troubleshooting – Pilot-Operated Valve” at the end of this Troubleshooting section.
	Low-pressure system is at fault.	Find “Low-pressure system partial or complete failure” under Probable Causes in this Troubleshooting section.
	At high-pressure inlet, the check ball has too much travel.	See Check Ball Travel at High Pressure Inlet, Figure A5-1. If the seats are leaking, see Ball Seat Refinishing, Figure B2 in the Repairs section of this manual.
	The high-pressure piston is stuck.	Disassemble, clean, and inspect the high-pressure bushing (75) and high-pressure piston (76). Replace parts as necessary.
Internal hydraulic fluid leak.		Inspect and replace as necessary: O-ring Plug (68) Cavity Insert (74) High-Pressure Bushing (75) High-Pressure Relief Valve (72)
		High-pressure relief valve failure.

Troubleshooting—Hydraulic Pump (cont'd)

Problem	Probable Cause	Probable Remedy
Ram will not hold pressure.	System has an external leak.	Visually inspect hoses, connectors and fittings for leaking hydraulic fluid. Replace faulty components.
	Manual control valve needs adjustment or repair.	See Hydraulic Schematic (8) and refer to Figures A2 and A3 in the Repairs section of this manual
	The manual control valve is not in correct position.	Rotate the manual control valve to AUTO RELEASE position.
	The manual control valve needs to be adjusted.	See Manual Release/Automatic Release Valve Handle Setting, Figure A3 in the Repairs section of this manual.
	Check ball does not seat properly.	See Manual Release/Automatic Release Valve Handle Setting, Figure A2, and Ball Seat Refinishing, Figure B4 in the Repairs section of this manual.
Ram will not retract.	The manual control valve is not in correct position.	Rotate the manual control valve to AUTO RELEASE position.
	The manual control valve needs to be adjusted.	Adjust the handle. See Manual Release/Automatic Release Valve Handle Setting, Figure A3 in the Repairs section of this manual.
	Quick-couplers are not fully threaded together.	Disconnect the hydraulic hoses and clean the couplings. Reconnect the hydraulic hoses. Hand-tighten couplings firmly until all threads are engaged. Do not use a wrench.
	Manual control valve set incorrectly.	See Hydraulic Schematic (8) and refer to Figures A2 and A3 in the Repairs section of this manual.
	The pilot-operated valve will not open, will not open fully, or opens too slowly.	See “Troubleshooting—Pilot-Operated Valve” at the end of this Troubleshooting section.
	Hydraulic cylinder of the accessory has failed.	Troubleshoot the accessory that is connected to the pump.

Troubleshooting – Pilot-Operated Valve

Problem	Probable Cause	Probable Remedy
Pilot-operated valve will not open. Pilot-operated valve will not open fully. Pilot-operated valve opens too slowly.	The pilot piston does not return freely.	See Hydraulic Schematic (7) and refer to Low-Pressure Relief Setting, Figure A4 in the Repairs section of this manual.
	Oil is cold.	Preheat oil. Without an accessory connected to the coupler, run the pump to build pressure, then release. Repeat until oil is warm.
	Wrong oil viscosity.	Replace oil with the type recommended in the Specifications section of this manual.
	Oil is dirty.	Replace oil with the type recommended in the Specifications section of this manual.
	Pilot piston components may be worn or damaged.	Clean and inspect items 42-49. Replace parts as necessary.
	Low-pressure bypass check valve is set incorrectly.	See Hydraulic Schematic (4). If set too low: The pump cannot shift to the high-pressure stage. See Pressure Adjustment for the Low-Pressure Bypass Check, Figure A5 in the Repairs section of this manual. If set too high: The pump cannot restart under pressure. See Pressure Adjustment for the Low-Pressure Bypass Check, Figure A5 in the Repairs section of this manual.
	The ball seat of the low-pressure bypass check-valve is damaged.	See Ball Seat Refinishing, Figure B2 in the Repairs section of this manual.

Troubleshooting – Pilot-Operated Valve (cont'd)

Problem	Probable Cause	Probable Remedy
Pilot-operated valve will not close.	A particle of dirt or some other foreign object is holding the low-pressure bypass check valve open.	Disassemble, clean and inspect spring (70) and 9/32" ball (71). Replace parts as necessary.
	Low-pressure bypass check valve is faulty.	See Hydraulic Schematic (4). If set too low: The pump cannot shift to the high-pressure stage. See Pressure Adjustment for the Low-Pressure Bypass Check, Figure A5 in the Repairs section of this manual. If set to high: The pump cannot restart under pressure. See Pressure Adjustment for the Low-Pressure Bypass Check, Figure A5 in the Repairs section of this manual.
	The ball seat of the low-pressure bypass check valve is damaged.	See Ball Seat Refinishing, Figure B2, B3 and B4 in the Repairs section of this manual.
	Low-pressure bypass check ball seat is oversized.	Replace the pump block (84).
	A particle of dirt or some other foreign object is holding the low-pressure relief valve open.	Disassemble, clean and inspect the valve piston (48), spring (47), ball (46), spring (45) and stem (44). Replace parts as necessary.
	Low-pressure relief valve is set too low.	See Low-Pressure Relief Setting, Figure A4 in the Repairs section of this manual.
	Low-pressure bypass check ball seat is damaged.	See Ball Seat Refinishing in the Repairs section of this manual. Figures B2, B3, and B4.
	Low-pressure bypass check seat is oversized.	Replace the pump block (84).
	The pilot piston does not advance freely	See Hydraulic Schematic (7). See Low-Pressure Relief Setting, Figure A4 in the Repairs section of this manual. Clean and inspect items 42-49. Replace parts as necessary.
	Valve seat is damaged.	See Hydraulic Schematic (3, 7).

Service

Motor Control Unit

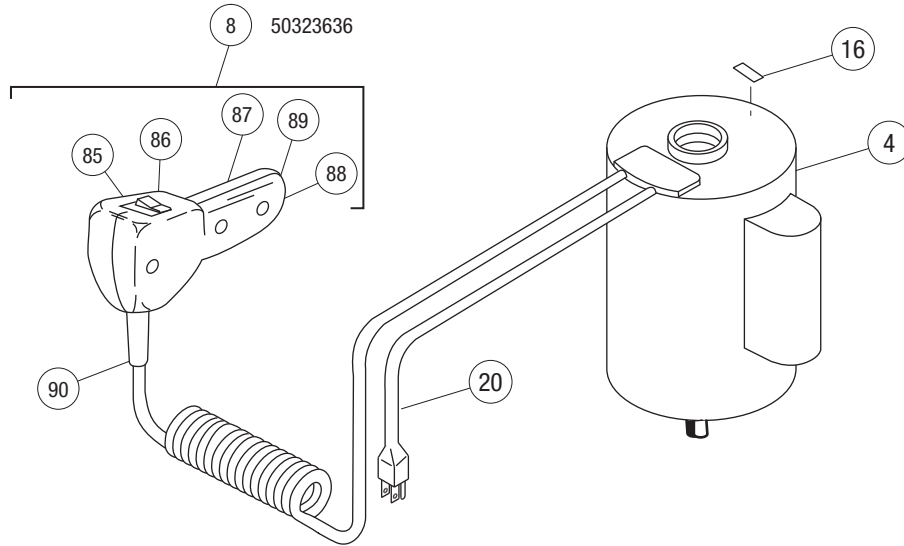

Pendant Switch Control Wiring

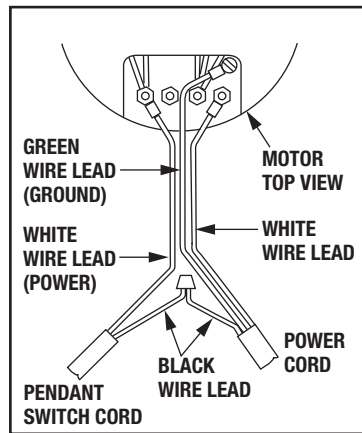

Pendant Switch Wiring

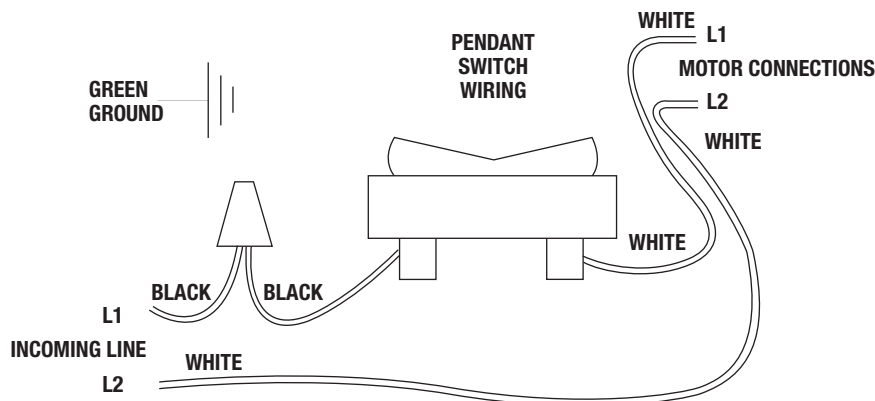

Service (cont'd)

Motor Control Unit

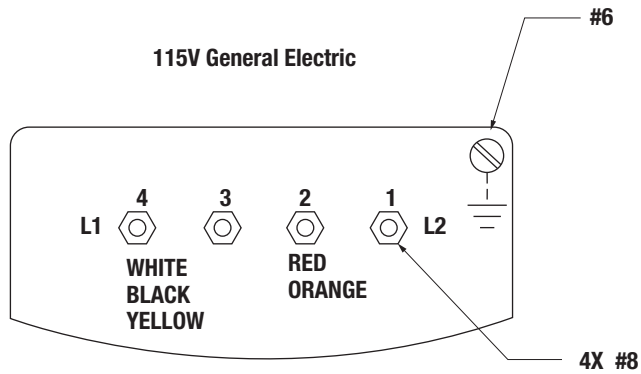
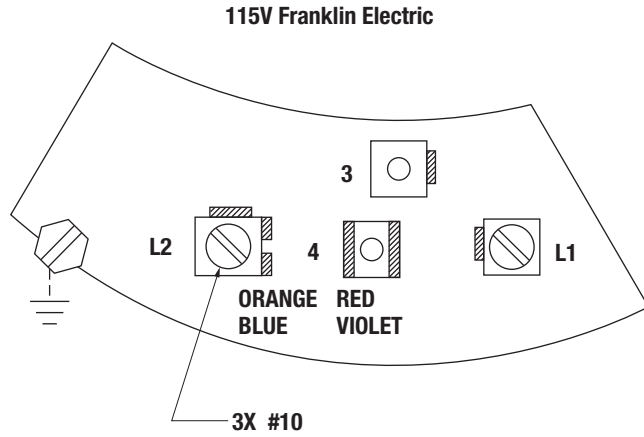

Service (cont'd)

Hydraulic Schematic

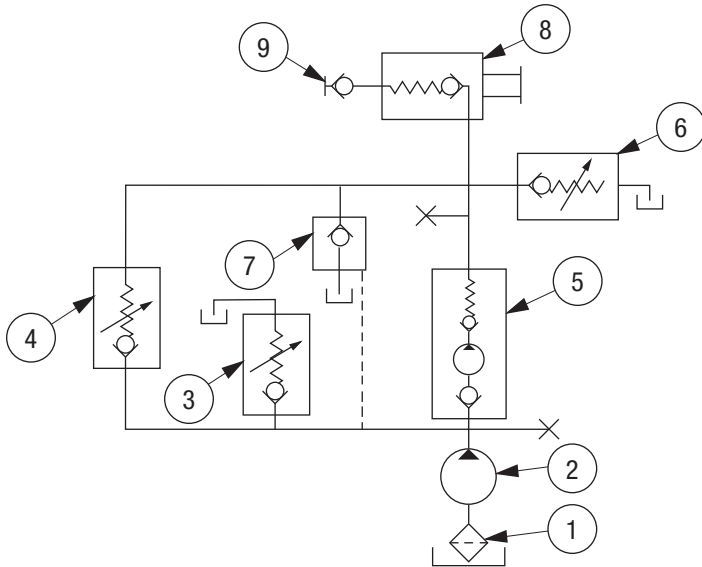

- ① Intake strainer, #50 mesh brass screen
- ② Low-pressure pump
5.5 liters/min. (335 in³/min) at 3600 rpm (100%)
- ③ Low-pressure relief valve — 19 bar (275 psi) located in pilot-operated valve ⑦ Piston
- ④ Low-pressure bypass check valve
- ⑤ High-pressure pump
.37 liters/min. (22.5 in³/min) at 3450 rpm (100%)
- ⑥ High-pressure relief valve
717/700 bar (10,400/10,000 psi)
- ⑦ Pilot-operated directional control valve
3 way, 2 position
- ⑧ Manually operated check valve
- ⑨ Female coupler half

Sealing Instructions for Assembly

Motor

If the motor has been disassembled, seal with a 3 mm (1/8") bead of a silicone-based gasket/flange sealant, such as Loctite® 587 Ultra Blue®, as follows:

- (A) To the mounting surface around the threads (four locations)
- (B) To the chamfer (four locations)
- (C) Around the innermost machined circumference of the mounting surface

Apply a 1.5 mm (1/16") bead of an RTV-type silicone-based sealant, such as Dow Corning 732™ Multipurpose Sealant, as follows:

- (D) Around the motor bearing screws (two locations)

Assemble immediately.

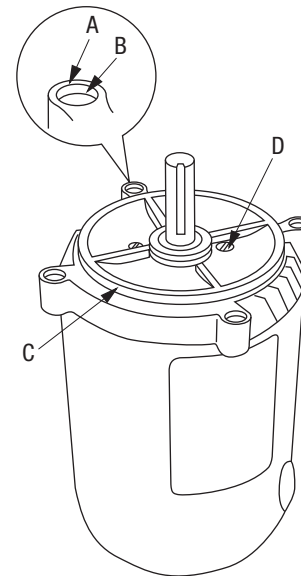

Driv-Lok Pin

Seal the Driv-Lok pin (73) to the pump block (84) with a 1.5 mm (1/16") bead of an RTV-type silicone-based sealant, such as Dow Corning 732™ Multipurpose Sealant or equivalent.

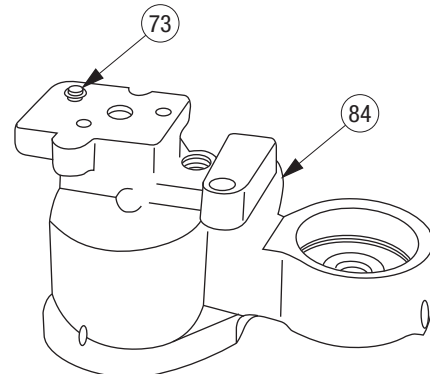

Repairs

The following section and Figures describe pertinent details for refinishing ball seats and component re-assembly and adjustments.

Motor Face Seal

When reassembling the motor, refer to Figure A1 for the face seal seating dimension. Also, refer to this figure for setting the vertical position of counterweight (32).

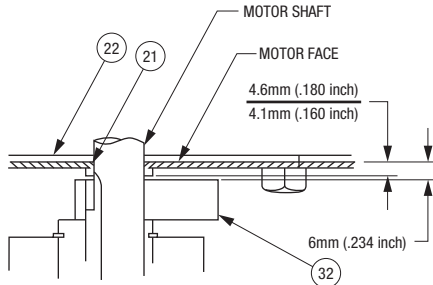

Figure A1 8

Manual Release/Automatic Release Valve Handle Setting

Refer to Figures A2 and A3. Thread in the shaft (62) until it just touches the check ball (55) (in its spring-loaded closed position). Slide collar (104) on the shaft. Position the handle (61) at the location "Position 1," (Figure A3), with the other surface of the handle flush with the end of the shaft. Lock in place. Rotate the handle to "Position 2," (Figure A3). Slide the collar toward the valve body until it contacts the 15.9 mm (5/8") diameter portion of the control shaft. Rotate the lock collar clockwise until it touches the stop pin, and lock in place.

When locking control handle and lock collar in place, torque set screws tight to 2.8–3.4 Nm (25–30 inch-pounds).

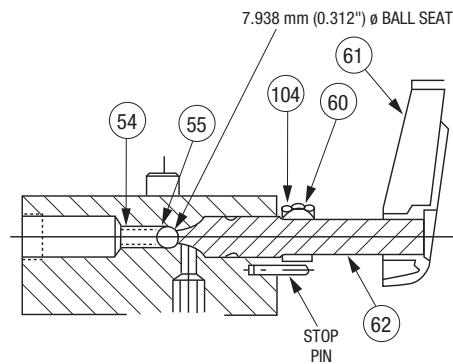

Figure A2 8

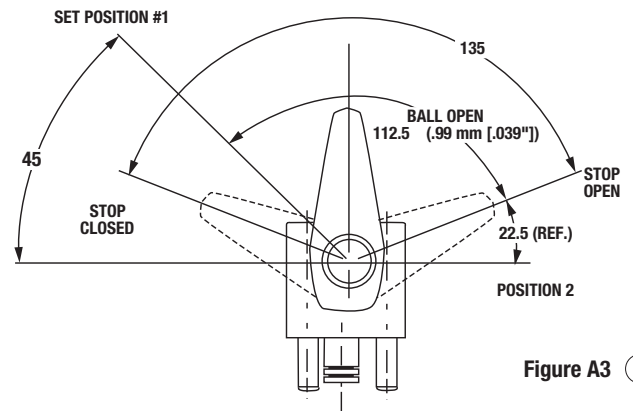

Figure A3 8

Repairs (cont'd)

Low Pressure Relief Setting

Refer to Figure A4. Lightly bottom the stem (44) on the ball (46). Then, back out the stem 3-1/2 turns. Tighten nut (43). The resulting pressure setting should be approximately 19.3 bar (280 psi).

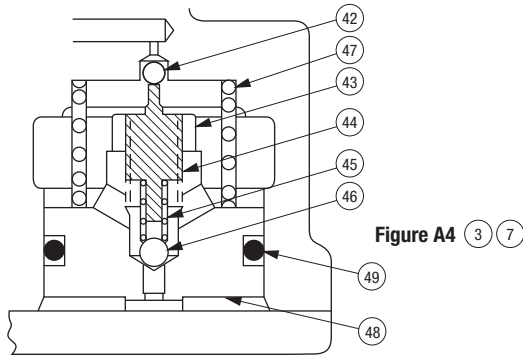

Figure A4 (3) (7)

Low-Pressure Bypass Check Pressure Adjustment

When properly set to the dimension shown in Figure A5, the high pressure stage operation of the pump will be delayed approximately one (1) second after the motor starts. This delay is created by the closing time of the pilot-operated valve.

Note: This dimension must be increased if ball seat depth is increased by more than .4 mm (1/64 inch).

Increasing the bypass pressure (CW rotation of adjusting screw— increase of set dimension) will shorten delay. If delay becomes too short, the motor will not restart when high pressure is held in the line. The motor should restart with a maximum required off time of 1/2 to 1 second.

Decreasing the bypass pressure (CCW rotation of adjusting screw) will increase delay. The pilot-operated valve will not close if pressure is set too low.

Changes in oil temperature (viscosity) will affect the amount of delay. The pumping delay will increase with rising oil temperature (thinner oil).

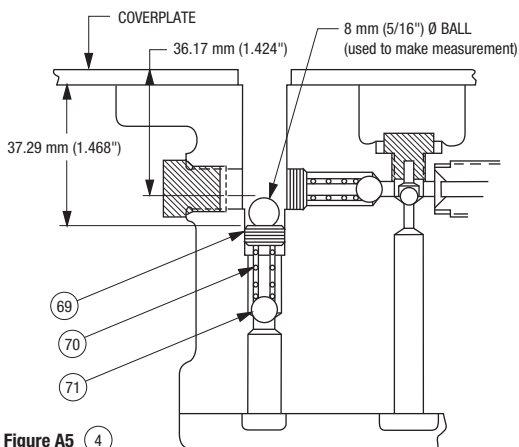

Figure A5 (4)

High-Pressure Inlet Check Ball Travel

The amount of allowable ball travel is critical to the optimum high pressure output (flow rate). Refer to Figure A5-1. Carefully and accurately measure (depth "mike") the "A" dimension (top of pump block to seated ball) and "B" dimension (top of pump block to head of plug—at center). Carefully and accurately set the "C" dimension (overall length of assembled plug and pin) of a new plug and pin equal to "A" minus "B" minus .305 ± .050 mm (.012 ± .002 inches).

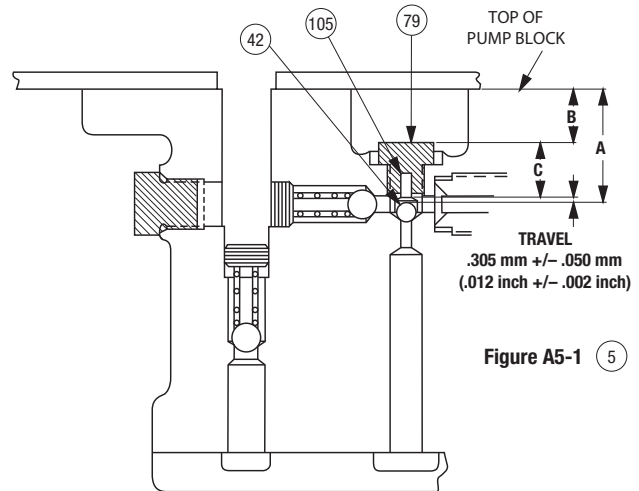

Figure A5-1 (5)

Low Pressure Pump Drive Pin

Assemble with cone point end in half-round keyway.

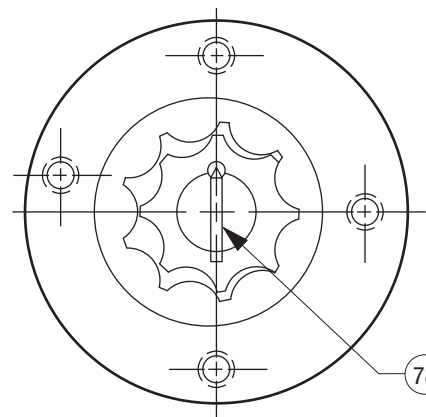

Figure A6

(78)

Repairs (cont'd)

Ball Seat Refinishing

Refer to Figures B2, B3, and B4 for the proper drill size to refinish the conical seat and finish ream size. These operations must be performed with the pump or valve block properly held and using a drill press. Only a very small amount of material should be removed.

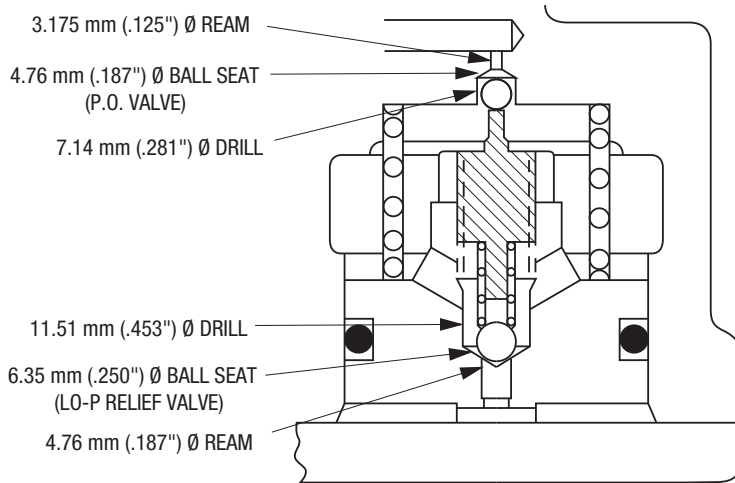

Figure B2 (3) (7)

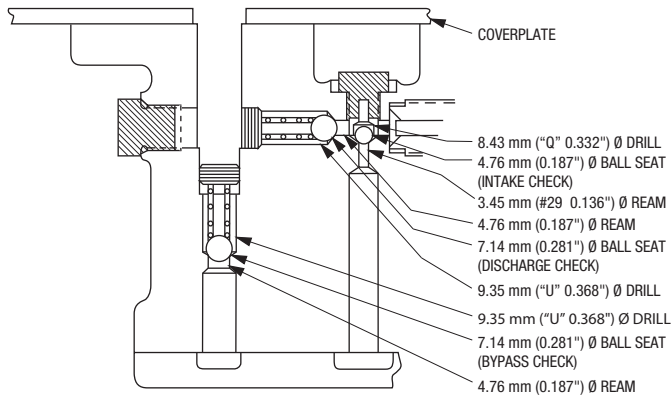

Figure B3 (4) (5)

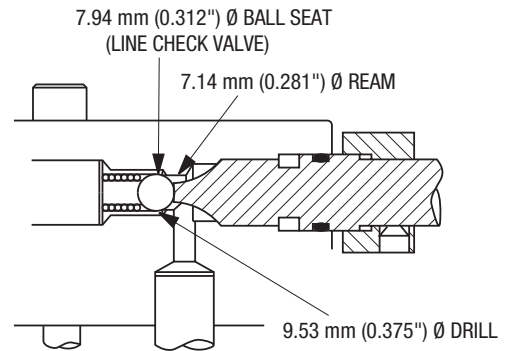
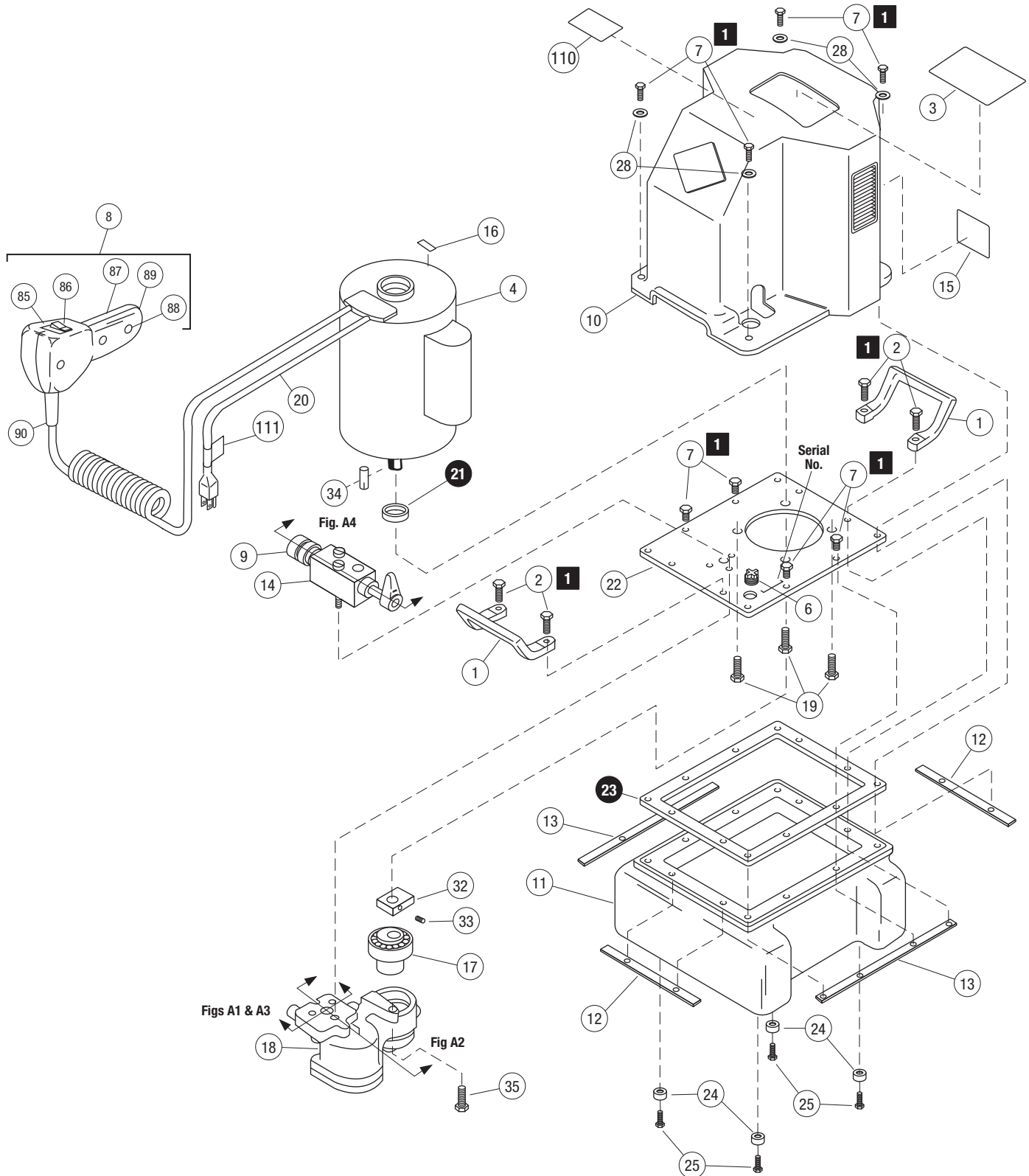
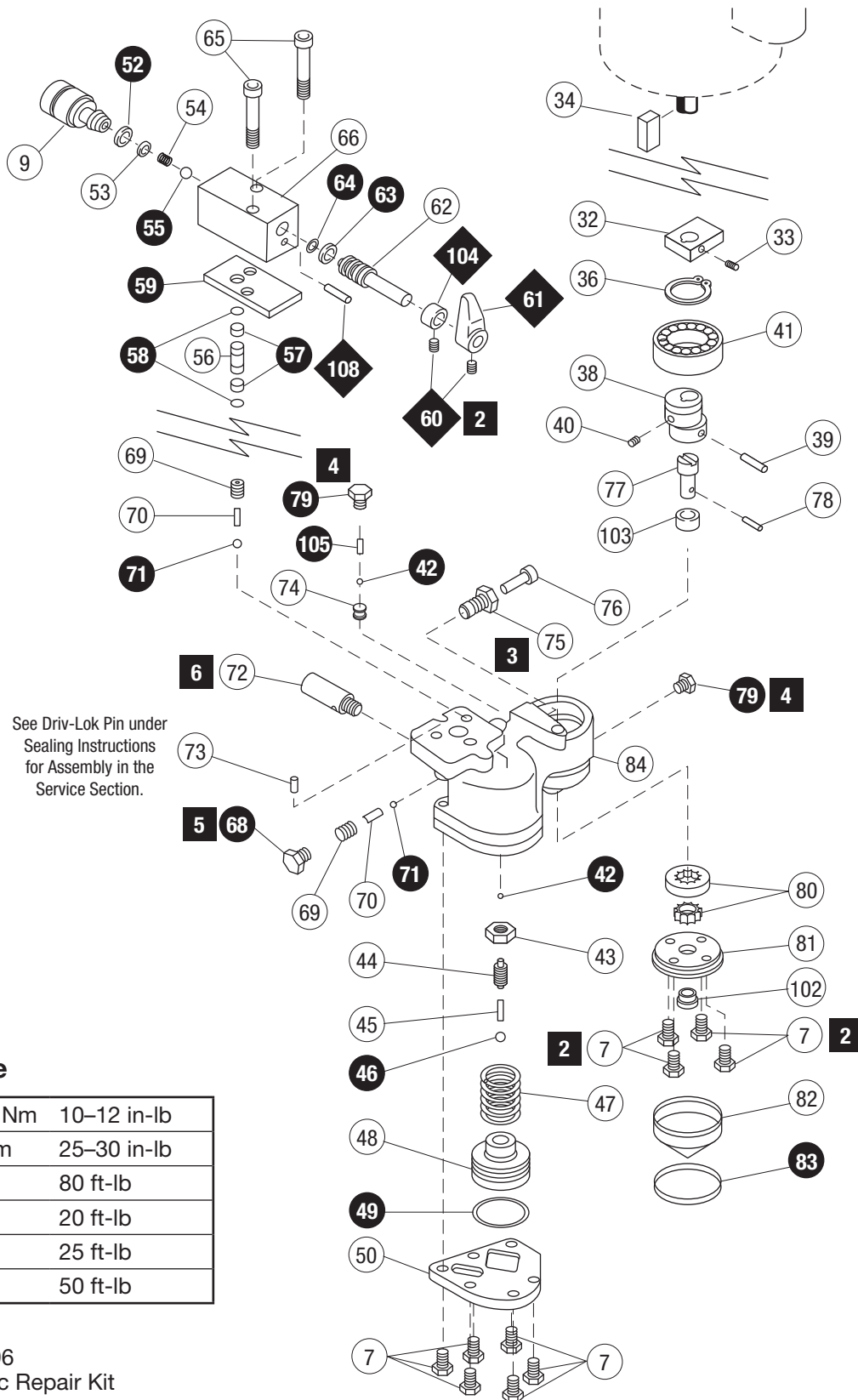

Figure B4 (8)

Exploded View



Exploded View—Pump Block



See Driv-Lok Pin under Sealing Instructions for Assembly in the Service Section.

Torque Table

1	1.13–1.35 Nm	10–12 in-lb
2	2.8–3.4 Nm	25–30 in-lb
3	110 Nm	80 ft-lb
4	27 Nm	20 ft-lb
5	34 Nm	25 ft-lb
6	68 Nm	50 ft-lb

 50343696
Hydraulic Repair Kit

 50354647
Release Knob Retrofit Kit

Parts List

Key	Part No.	Description	Qty
1	50335189	Carrying Handle	2
2	90537092	1/4-20 x 1-1/4" Hex Head Screw	4
3	50337211	Decal	1
4	91863392	Motor, 115 VAC, 1/2 hp..... GE 5CK36JN268X Franklin 1103007415	1

SERVICE PARTS:		GE	FE
Capacitor	Greenlee No.	91863775 ①	91865034 ②
	Manufacturer No.	111A271P1 ①	275469110 ②
Cover, Cap	Greenlee No.	91865026	91865042
	Manufacturer No.	111B275AA1	276756101

6	52058082	Plug with O-ring	1
7	90505204	1/4-20 x 3/4" Hex Head Screw.....	18
8	50323636	Pendant Switch Unit (includes 85-90).....	1
9	90508076	Coupling	1
10	50334891	Shroud.....	1
11	50334905	Reservoir	1
12	50335359	Short Retaining Strap	2
13	50335367	Long Retaining Strap	2
14	50335375	Release Valve Unit	1
		(includes 52-66, 104, 108)	
15	50337238	ID Decal.....	1
16	50158325	Arrow Decal	1
17		Eccentric Unit.....	1
		(see next page for breakdown)	
18		Pump Block Unit	1
		(see next page for breakdown)	
19	90505301	Hex Hd. Cap Screw 3/8-16 x 1.00"	3
20	91862965	Power Cord	1
*21	90536827	Seal	1
22	50335170	Cover Plate	1
*23	50326279	Cover Plate Gasket	1
24	90538293	Rubber Foot	4
25	90511859	Screw, 1/4-20 x 1/4"	4
28	90523393	1/4" Flat Washer	4
32	50335278	Counterweight.....	1
33	90512693	Set Screw, 1/4-20 x 1/4"	1
34	50145576	Motor Shaft Key, 3/16" x 1-3/8".....	1
35	90505336	Hex Hd. Cap Screw, 3/8-16 x 1.50"	1
36	90537076	Retaining Ring	1

Parts List (cont'd)

Key	Part No.	Description	Qty
38	50335260	Eccentric Shaft.....	1
39	90506995	Rollpin, 3/16" x 1"	1
40	90507916	Set Screw, 10-32 x 1/4".....	1
41	90537041	Ball Bearing, #3206.....	1
*42	90506782	Ball, 3/16"	2
43	90500164	Jam Nut, 1/2-20	1
44	50335200	Stem.....	1
45	50325345	Spring, .240" O.D x .750"	1
*46	90506790	Ball, 1/4"	1
47	90537017	Spring, 1.460" O.D x 1.500"	1
48	50335197	Auto Valve Piston	1
*49	90503406	O-ring, 1-5/8" x 2" x 3/16"	1
50	50335219	Pump Block Cover.....	1
*52	90535030	Retaining Ring	1
53	90534689	Plain Flat Type "A" Washer #10	1
54	90535103	Compression Spring, .240" O.D. x .687"	1
*55	90506804	Ball, 5/16"	1
56	50326228	Coupling.....	1
*57	90512901	Back-up Ring, 3/8" x 1/2" x 1/16"	2
*58	90501683	O-ring, 3/8" x 1/2" x 1/16"	2
*59	50326260	Gasket	1
+60	90512693	Set Screw, 1/4-20 x .38"	2
+61	50347969	Release Valve Knob	1
62	50335413	Control Shaft.....	1
*63	90538277	Back-up Ring, 1/2" x 5/8"	1
*64	90509129	O-ring, 1/2" x 5/8" x 1/16"	1
65	90534964	Cap Screw, 5/16-18 x 2.50"	2
66	50326236	Release Valve Body	1
*68	90536983	O-ring Plug (includes 107).....	1
69	90537122	Jam Screw, 7/16".....	2
70	90537025	Spring, .240" O.D x .810	2
*71	90504364	Ball, 9/32"	2
72	50060678	High Pressure Relief Valve	1
73	90537068	Type "D" Driv-Lok Pin, 1/4" x 1/2"	1
74	50343106	Insert, Cavity	1
75	50335316	High Pressure Bushing	1
76	50335324	High Pressure Piston	1
77	50335251	Drive Shaft	1
78	50329340	Drive Pin, 1/8" x 5/8"	1
*79	90536991	O-ring Plug (includes 106).....	1
80	90535170	Gerotor	1

Parts List (cont'd)

Key	Part No.	Description	Qty
81	50341979	Lower Gerotor Plate Unit (includes 102)	1
82	50335243	Filter	1
*83	90537661	O-ring, 2-3/8" x 2-5/8" x 1/8"	1
84	50335332	Pump Block.....	1
85	50323709	Faceplate Decal	1
86	91862655	Switch, Rocker	1
87	50319027	Handle, Right Half	1
88	90534417	Self-Tapping Screw, 6-20 x 5/8"	3
89	50319019	Handle, Left Half	1
90	50323628	Cord, Pendant.....	1
102	90538390	Bearing, Bronze	1
103	90533208	Bearing, Bronze 1/2" x 5/8" x 1/2".....	1
+104	50348868	Shaft Stop Collar.....	1
*105	90538161	Pin, 1/8" x 1/4" Driv-Lok	1
+108	90500784	Roll Pin, .187" Dia. x 3/4" Long	1
109	4016GB	Hydraulic Oil, 1 gal, ea.	1.5
	4017GB	Hydraulic Oil, 1 qt, ea.....	6
110	500 2581.3	Decal, caution	1
111	502 2510.3	Decal, caution	1

Greenlee Hydraulic Oil (Mobil DTE® 13M)

90510593 / 4016GB	1 gallon
90508068 / 4017GB	1 quart

* Parts included in Hydraulic Repair Kit No. 50343696

+ Parts included in Release Knob Retrofit Kit 50354647

①	440 µfd.	Grainger	#1A569	1B/16Ø x 3-3/8	↓	PSA4R 10400N
②	460-552 µfd.	Grainger	#4X070	1B/16Ø x 4-3/8	Aero	PSA5R 10460N



USA	800-435-0786	Fax: 800-451-2632
	815-397-7070	Fax: 815-397-1865
Canada	800-435-0786	Fax: 800-524-2853
International	+1-815-397-7070	Fax: +1-815-397-9247

4455 Boeing Drive • Rockford, IL 61109-2988 • USA • 815-397-7070
 An ISO 9001 Company • Greenlee Textron Inc. is a subsidiary of Textron Inc.

www.greenlee.com